

Truck & Bus All Steel Radial

**TECHNICAL AND COMMERCIAL  
DATA BOOK** **GLOBAL**  
**2022**



# Contents

## Company Profile

---

Giti Facts	4
A Singapore-Based Global Tire Company	5
A Strong Presence All Around the World	6
Giti Tire's Global One R&D	7
World Class Manufacturing Facilities	8
Global Fleet Customers	9
Global OEM Customers	10
Giti Competition Truck Racing	11
Commercial Truck & Bus Tires	12

## Product Map

---

<b>Product Offering</b>	30
Features, Advantages & Benefits with Tire Size Ranges	

---

<b>Giti Truck &amp; Bus Tire OEM Partners</b>	94
---	----

---

## Tire Basics

---

Designations, Load and Speed Index	101
Naming Conventions	102
Bias and Radial Tire Comparison	103
Tube and Tubeless Tire Comparison	107

## Tire Management, Care & Maintenance

---

Six Steps to Simple Tire Maintenance	117
Tire Pressure Management	118
Wheel Alignment/Toe-Setting	121
Technical Specification	122
Tire Rotation Management	123
Essential safety Information	124
Tire Mounting/Demounting	125
Simple Tubeless Tire Repair Technique	127
Giti Truck Tire Usage Recommendations	130

---

<b>How to Identify a Better Truck Tire</b>	137
--	-----

---

<b>Wheel Rim Classification</b>	174
---------------------------------	-----

# **Section 1**

## **Company Profile**

**5**

**R&D and Tire Testing Centers**

4 R&D in China, the U.S., Germany, Indonesia, and 1 Tire Testing Center in the Indonesia

**5**

**Manufacturing Plants**

3 in China, 1 in Indonesia, and 1 in the U.S.

**10** Offices

Singapore, China, Indonesia, U.S., Canada, U.K., Germany, France, Dubai, Malaysia

# Giti Facts

More than

**30,000**

Employees  
Worldwide

More than

**70,000**

Point of Sales  
In more than 130  
countries

# A Singapore-Based Global Tire Company

With its roots going back more than 70 years in the tire industry, Giti Tire understands the requisites of being a resilient and consistent tire manufacturer in the highly competitive and fast changing marketplace, and has the necessary resources in place.

Today, the Giti business platform fully integrates its worldwide manufacturing and R&D footprint, and innovative sales, marketing, and distribution channels together with its global motorsports activities to assure its future growth.



Scan to find out more



# A Strong Presence All Around the World

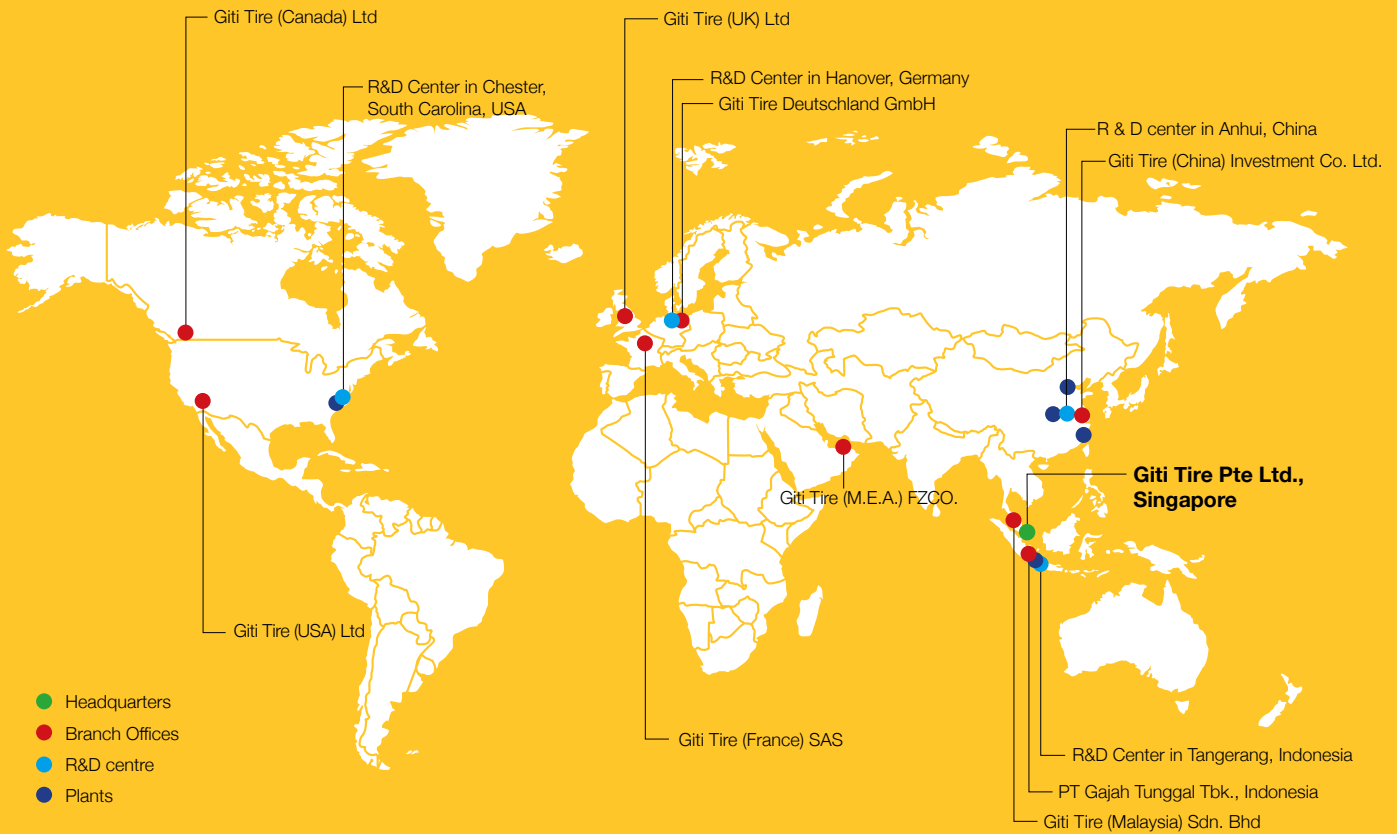

## COMPREHENSIVE PRODUCT RANGE

Tire For Any Road, Any Vehicle, Any Journey

Consumer		Commercial		Specialty		Motorcycle	
	Ultra high performance		Truck		Agriculture		Street used
	Touring		Dump truck		Earth mover & industrial		Off road
	SUV & light Truck		Bus		Monorail		Competition
	Winter		Commercial van		Air craft		



## Giti Tire's Global One R&D

continuously advances its technology platform to provide shorter timelines from new product concepts to market availability.

### Global One R&D



# World Class Manufacturing Facilities

When you put on a set of Giti Tire on your vehicle, you can be confident that your tires have been put through one of the most rigorous and comprehensive quality control systems in the industry.

- Current construction of a full new tire production facility in South Carolina of the United States
- Eight Giti facilities have an annual capacity of over **111,000,000** tires
- All plants have obtained **ISO/TS16949:2009** accreditation (a highest standard of quality control) and ISO14001-2004 Environmental Management System Accreditation
- Very strict quality controls and inspections at each stage of the production process to ensure that each component meets relevant specifications and standards

## Internationally Accepted Product Quality and Accreditation



One of the Giti's five manufacturing bases



A Giti Tire production line





## NOTABLE AWARDS



### BYD

- BYD Core Supplier



### CHANGAN

- Changan Auto Supplier Quality Certification



### GEELY

- Loyalty Award Of Supplier Conference 2019



### Foton

- 2020 Gold Award for quality leadership of excellent suppliers



### JAC

- Win-Win Cooperation Award



### SAIC

- Excellent Quality Management



### Foton

- 2020 excellent supplier quality leading Award
- Outstanding performance award

### ASIASTAR

- Excellent Suppliers in 2020

### JMC

- 2020 Supplier Grade Certificate Grade A Supplier



### JAC

- 2020 Win Win Cooperation Award



### BEIBEN

- 2020 Excellent Supplier Award

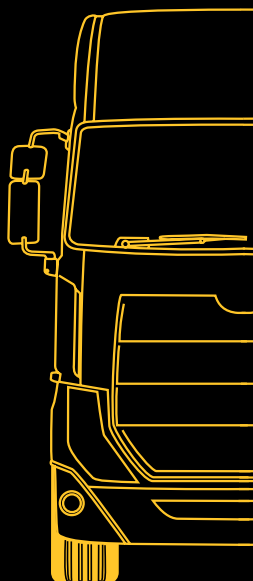

## GLOBAL FLEET CUSTOMERS

### TRANSPORTING HAZARDOUS MATERIALS



### CITY BUS



### LOGISTICS COMPANIES



### HEAVY DUTY CONTAINERS



### HAULAGE OPERATORS



# GLOBAL OEM CUSTOMERS

Over 400 Models

Truck Tire  
OE Customers



Bus Tire  
OE Customers



# Giti Competition Truck Racing



**GitiCompete  
RACE-TUNED V1**

**Giti Tire** has taken its top level racing capabilities to include trucks. Competing on some of the toughest tracks throughout Europe, the racing also provides a chance for extreme testing and analysis of its specialty truck competition tire, which is also used into maximizing the performance of Giti's other TBR offerings.

# Commercial Truck & Bus Tires

---

Giti Tire trucks provide diverse tire solutions to meet the needs of various road conditions and driving habits for commercial customers. Giti knows that durability, safety, and efficiency are paramount to companies that need to succeed in daily business while lowering expenses, and focus our efforts on providing positive solutions to the needs of clients. Giti is committed to helping transportation companies achieve sustainable transportation with energy saving tires.

By collaborating with the World Bank, and the U.S. EPA SmartWay Program, and local government organizations, Giti Tire has become a focused partner in energy preservation. Giti has also developed a series of energy saving and fuel efficient tires to adapt to industry trends. A top line of TBR tires is available to meet your business' needs. Below are a few of our more popular patterns available for the ASEAN market.



# Section 2

## Product Map



- T2** Truck Series - Line Haul
- T1** Truck Series - Highway & Regional
- D1** Truck Series - Off/On Road
- D2** **D3** Truck Series - On/Off Road
- B1** Bus & Coach Series - Intercity & Regional Bus
- B2** Bus & Coach Series - Line Haul Coach
- B3** Bus & Coach Series - City Bus & Urban Haulage
- LTT** Light Truck Series - Regular Transport
- LTD** Light Truck Series - Dumper
- LB** Light Bus series - Light Bus

# T2 Truck Series - Line Haul



Long Distance  
High Wearing Resistance  
High speed

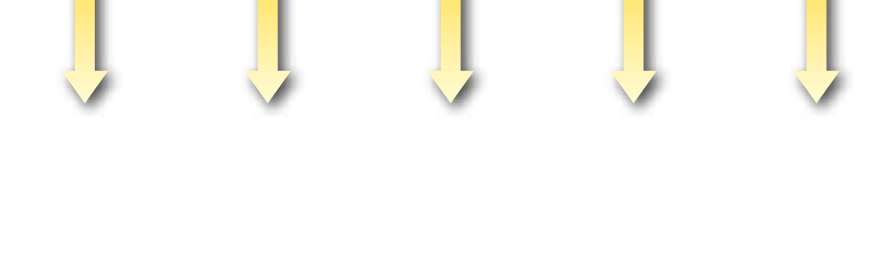



Short Distance  
High Cut and Chip Resistance  
Low speed



**Tyre Position** - Good performed in this environment / Road Condition  
**Arrow** - Products use for this road condition



 Steer/All Position (optional)  Drive  Trailer

# T1 Truck Series – Highway & Regional / Heavy & Medium Truck

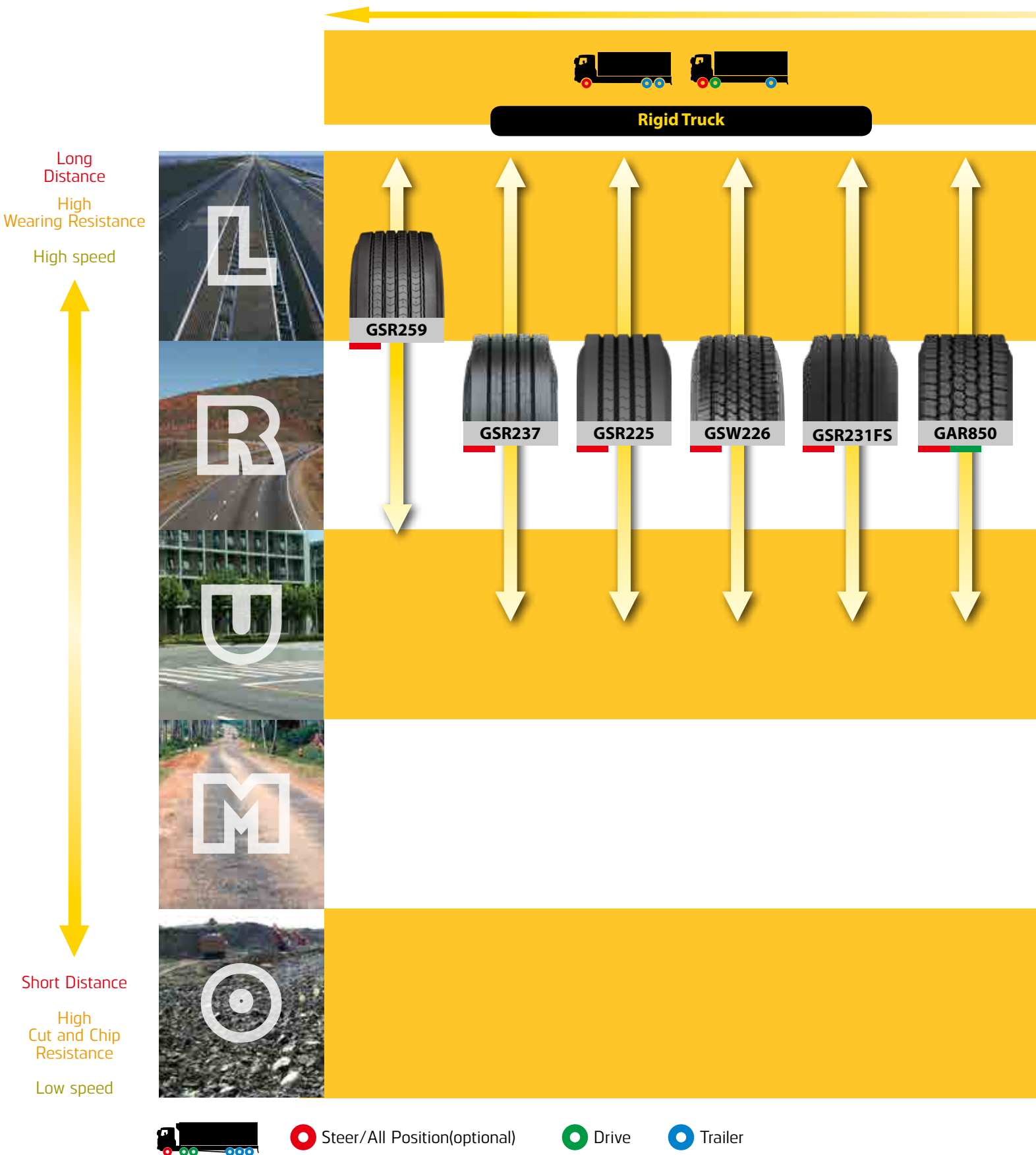



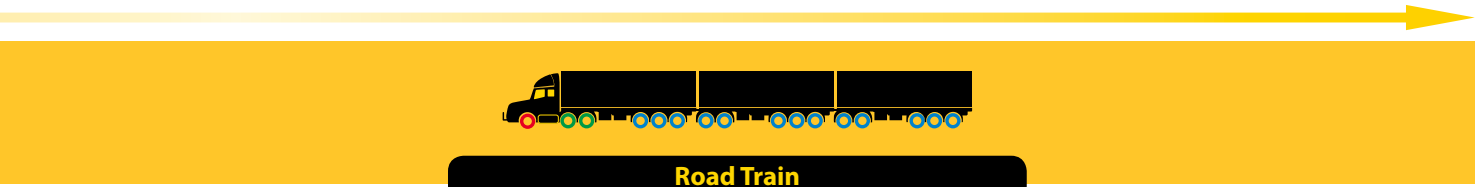

— Steer/All Position (optional) — Drive — Trailer

# T1 Truck Series – Highway & Regional / Heavy & Medium Truck

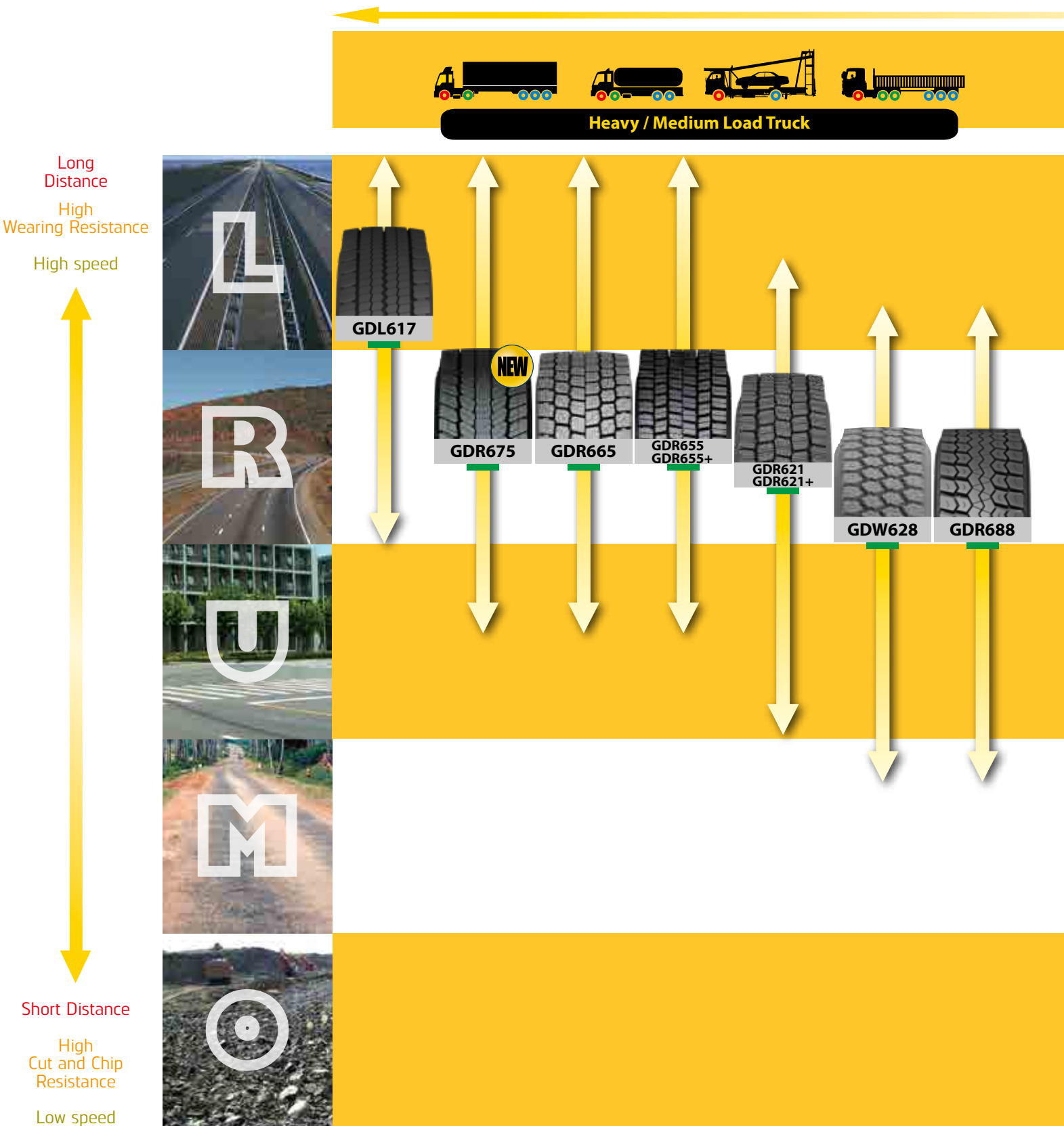

Steer/All Position(optional)



Drive



Trailer

**Tyre Position** - Good performed in this environment / Road Condition

**Arrow** - Products use for this road condition



■ Steer/All Position (optional)
 ■ Drive
 ■ Trailer

# D1 Truck Series – Off /On Road



Long Distance  
High Wearing Resistance  
High speed



Short Distance  
High Cut and Chip Resistance  
Low speed

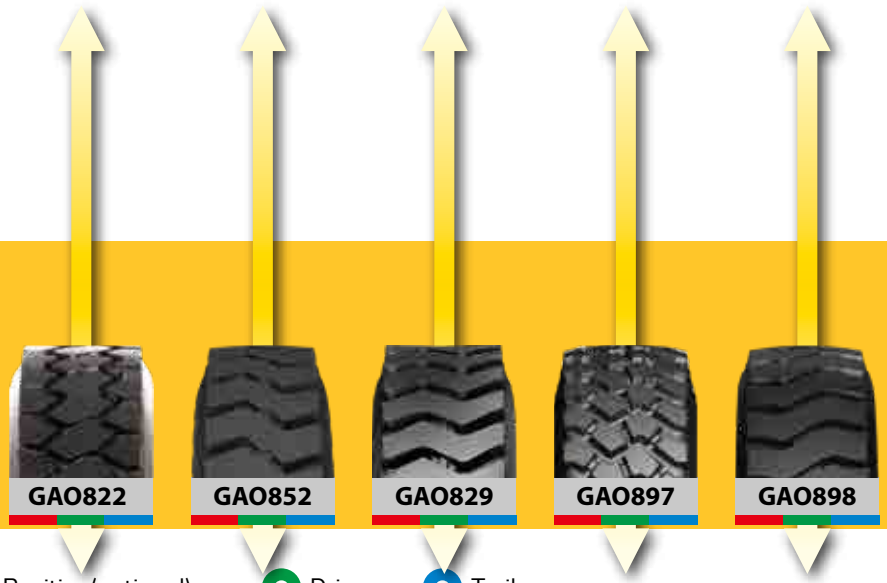

Steer/All Position(optional) Drive Trailer

**Tyre Position** - Good performed in this environment / Road Condition  
**Arrow** - Products use for this road condition

# D2 / D3 Truck Series – On/Off Road



Dumper Trailer

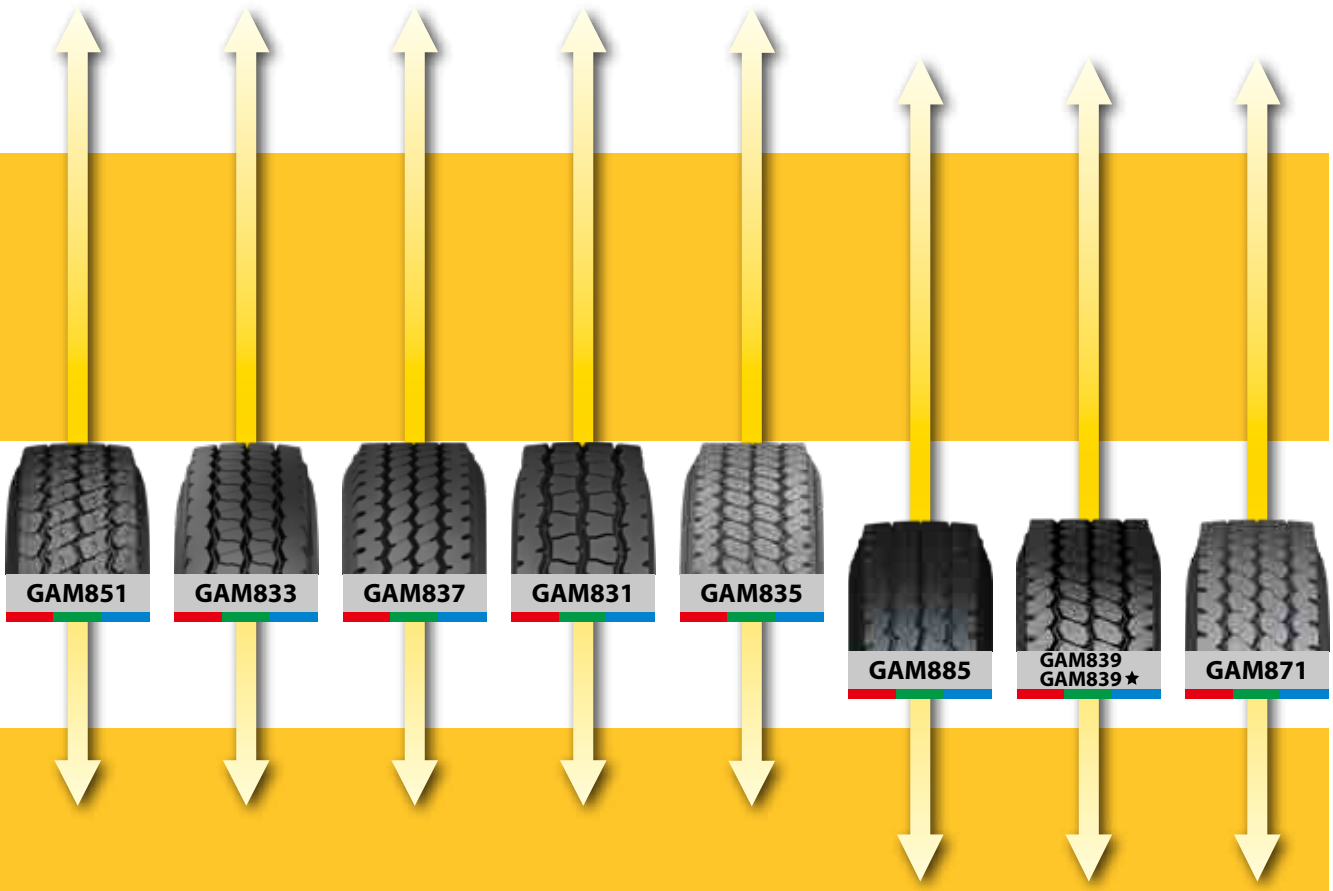

Red Steer/All Position (optional) Green Drive Blue Trailer

# D2 / D3 Truck Series – On/Off Road

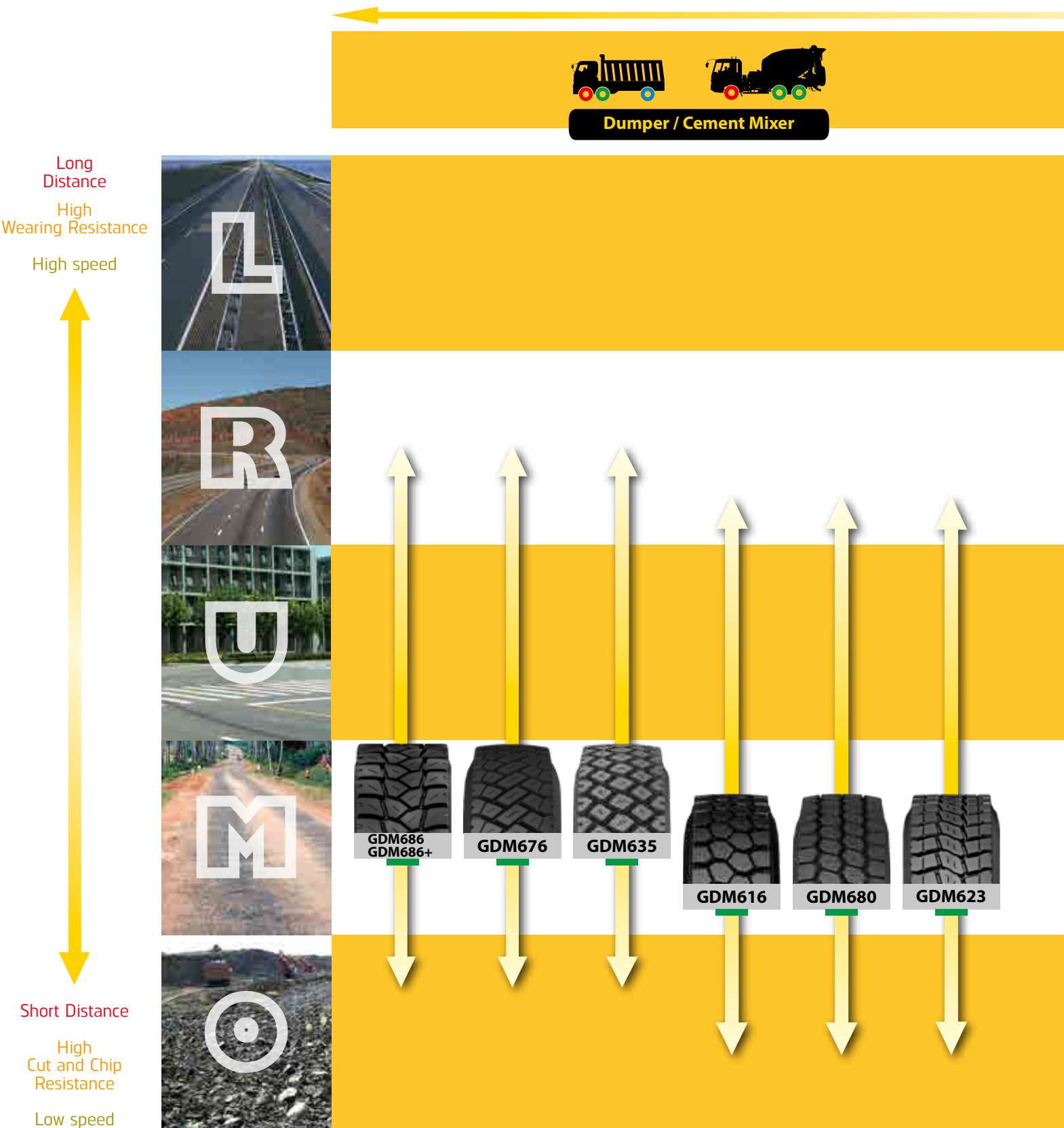

Steer/All Position(optional)



Drive



Trailer

**Tyre Position** - Good performed in this environment / Road Condition

**Arrow** - Products use for this road condition



— Steer/All Position (optional)    — Drive    — Trailer

# B1 Bus & Coach Series – Intercity & Regional Bus

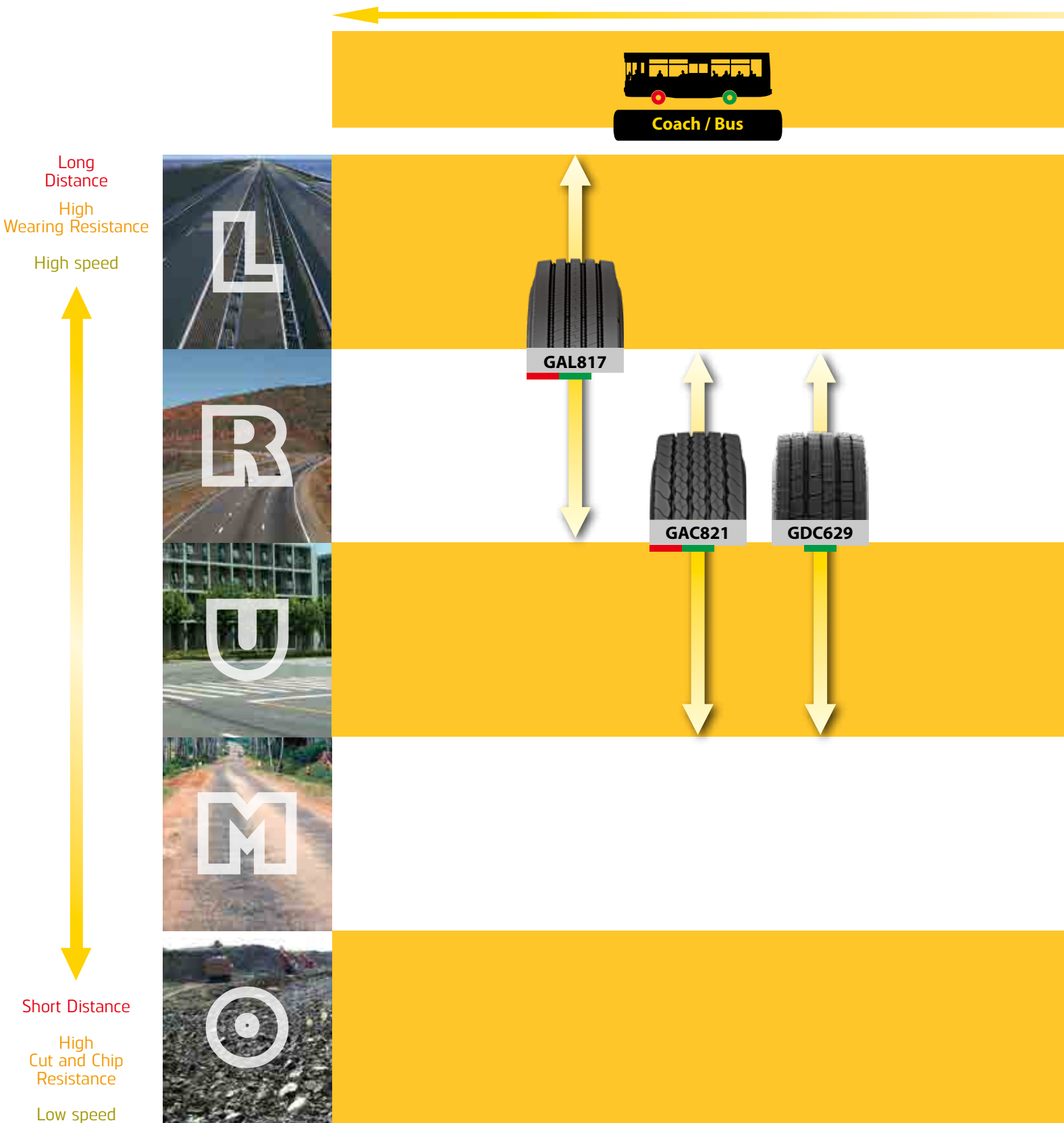

Steer/All Position(optional)



Drive



Trailer



**Tyre Position**· Good performed in this environment / Road Condition

**Arrow**· Products use for this road condition



# B2 Bus & Coach Series – Line Haul Coach



 Steer/All Position (optional)    Drive    Trailer

# B3 Bus & Coach Series – City Bus & Urban Haulage

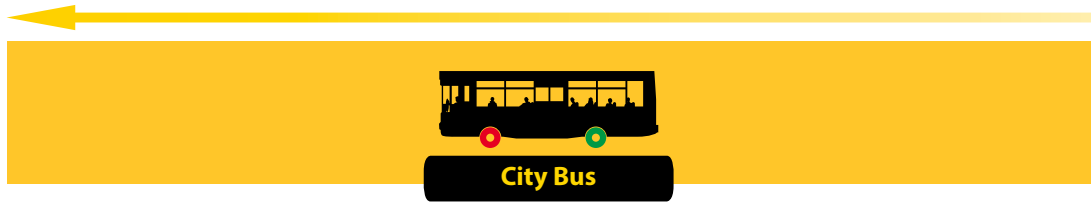

Long Distance  
High Wearing Resistance  
High speed



Short Distance  
High Cut and Chip Resistance  
Low speed



Steer/All Position(optional)



Drive



Trailer

**Tyre Position** - Good performed in this environment / Road Condition

**Arrow** - Products use for this road condition

# LTT Light Truck Series – Regular Transport

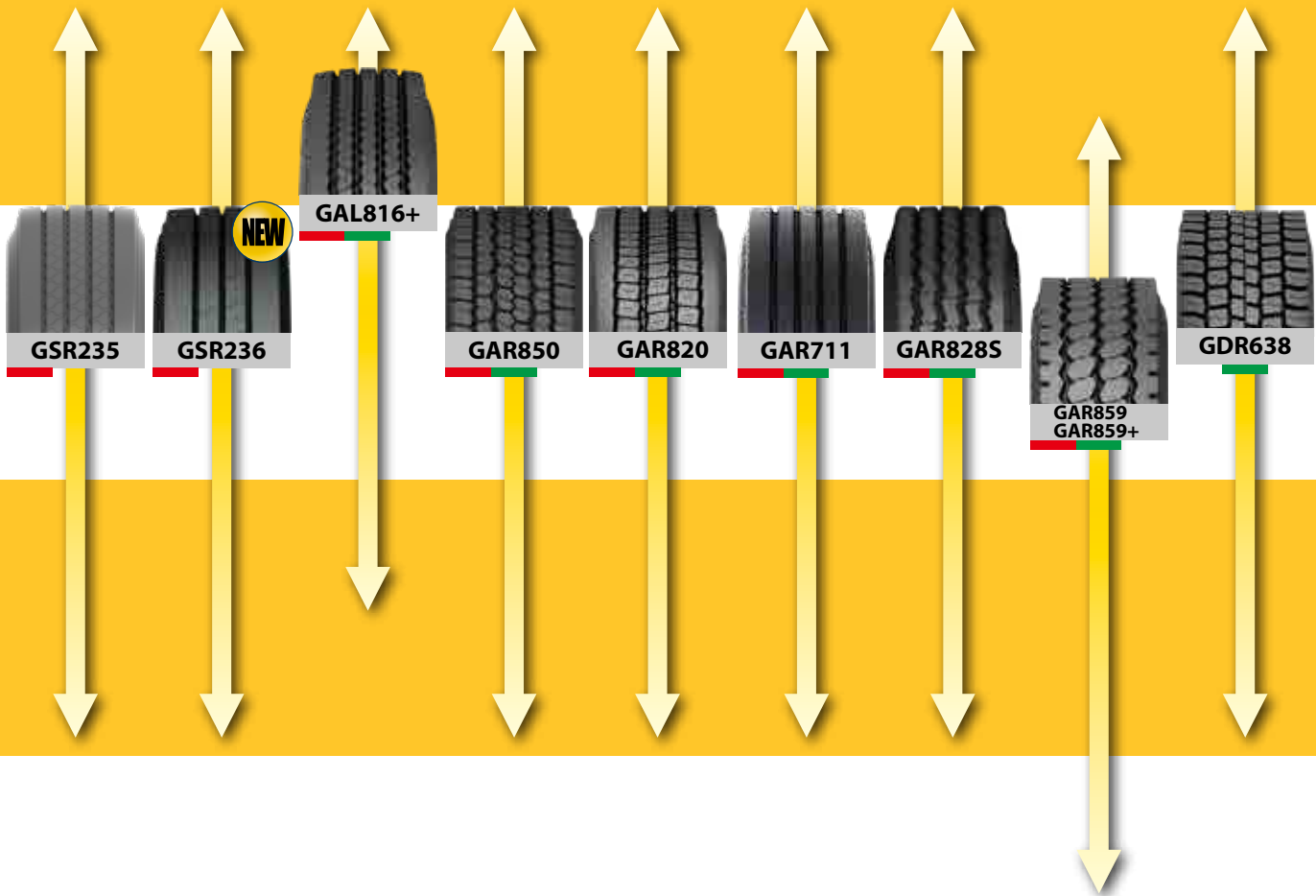

Steer/All Position (optional) Drive Trailer

# LTD Light Truck Series – Dumper

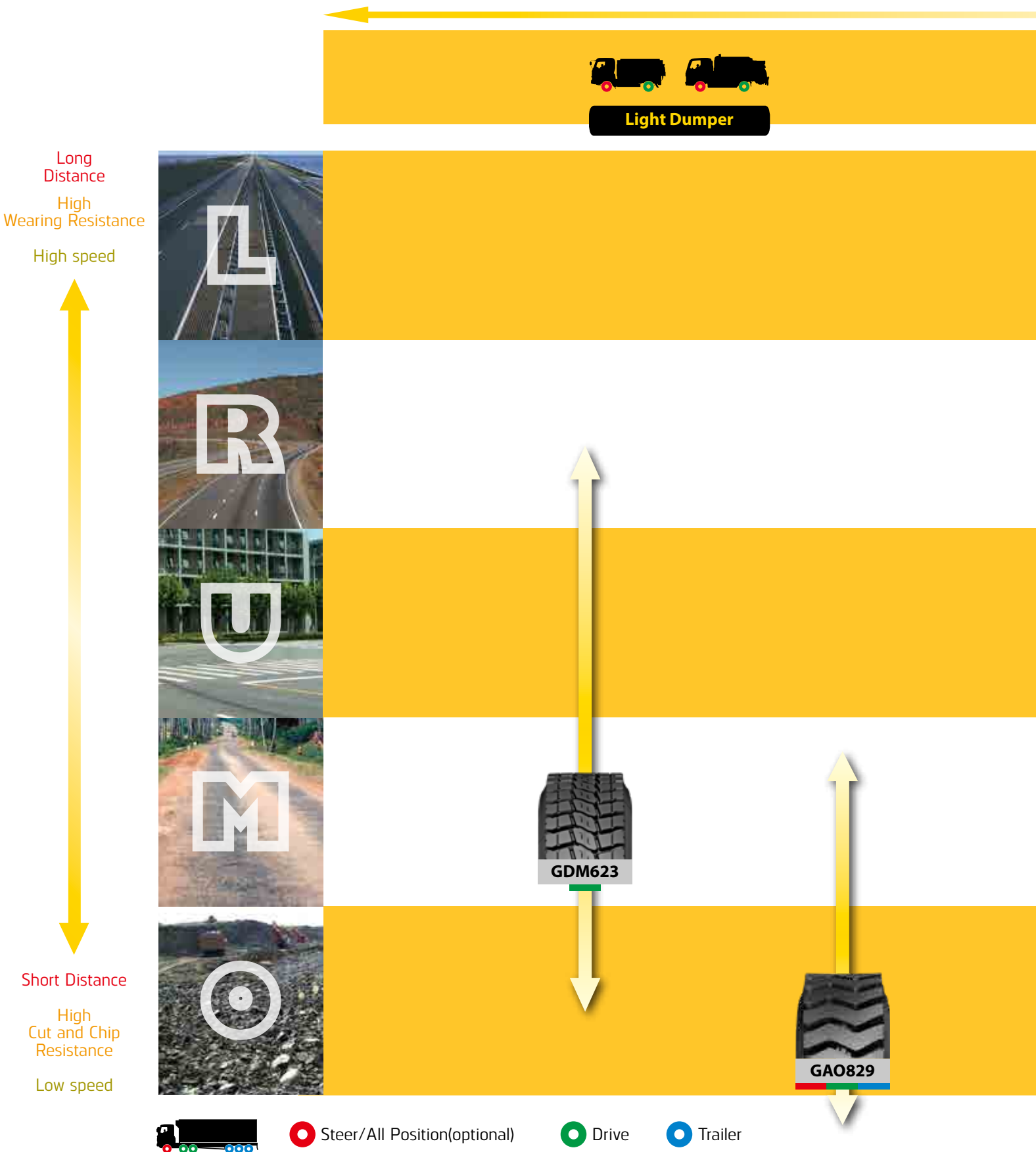

**Tyre Position** - Good performed in this environment / Road Condition  
**Arrow** - Products use for this road condition

# LB Light Bus series – Light Bus

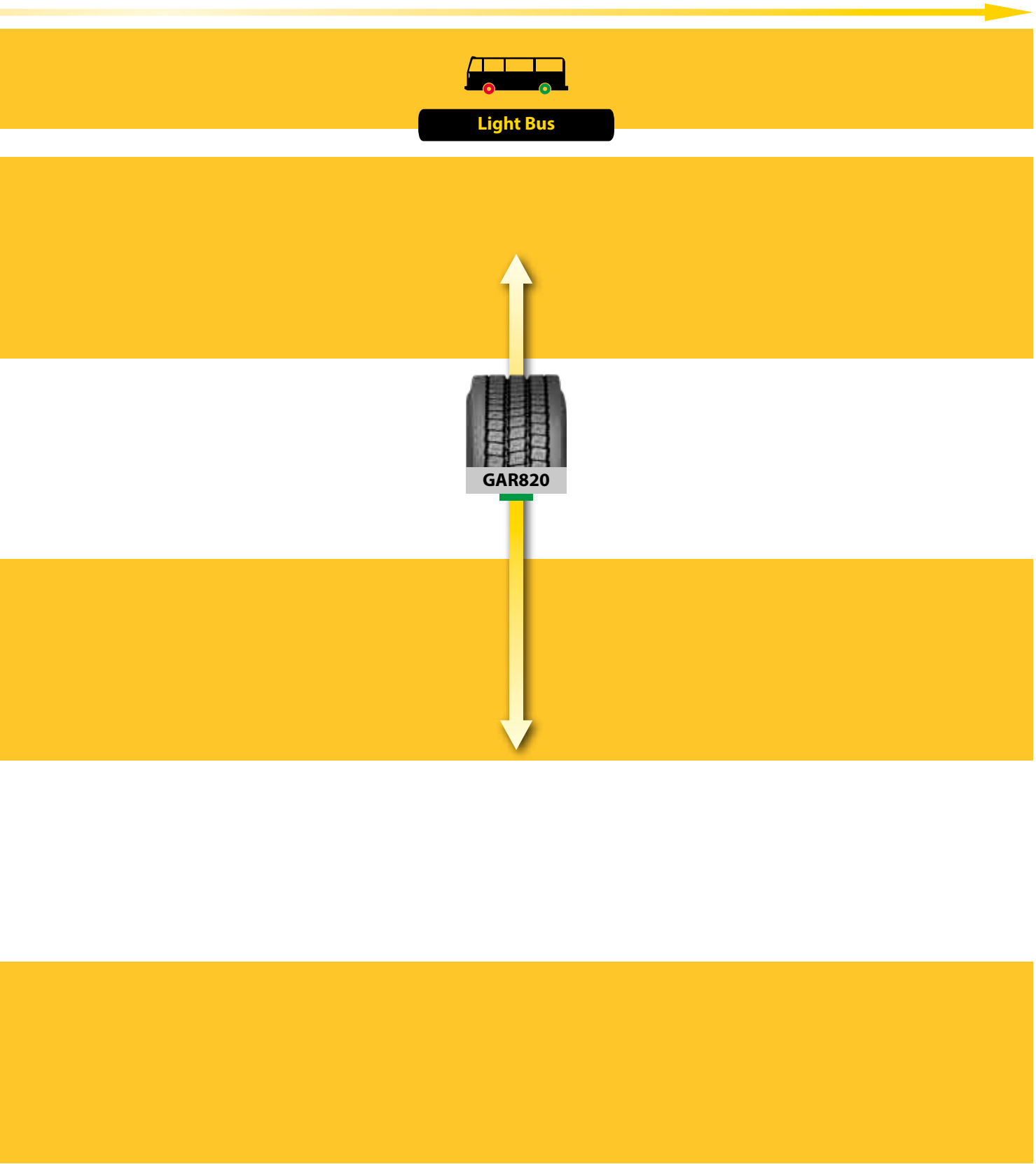

— Steer/All Position (optional) — Drive — Trailer

# **Section 3**

## **Product Offering**

**Features, Advantages & Benefits with  
Tire Size Ranges**



Truck Series-Line Haul

# GSL229FS







For trucks, Steer position



Long Haul

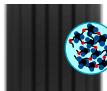

- **Longer Mileage and Improved Fuel Economy**
- **Resists Irregular Wear**

Features	Advantages	Benefits
 <p>Fuel saving compound</p>	Lower rolling resistance and higher fuel economy	<b>Lower fuel consumption</b>
 <p>Extra wide and deep tread</p>	Outstanding tread life	<b>Deliver long mileage and operation life</b>
 <p>Defense ribs</p>	Effectively prevents initiation of irregular wear	
 <p>Optimized footprint distribution</p>	Improves footprint performance to prevent irregular wear	

Size	PR	Load Index	Speed Rating	Standard Rim	Maximum Load		Maximum Pressure		Tread Depth (mm)	Outer Diameter (mm)	Section width (mm)	TL/TT
					kg	lbs	kPa	psi				
11R22.5	14PR	144/142	L	8.25	2800/2650	6175/5840	720/720	105/105	14.3	1054	279	TL
295/75R22.5	14PR	144/141	L	9.00	2800/2575	6175/5675	760/760	110/110	15.1	1014	298	TL

TL Tubeless Tire



Truck Series-Line Haul





# GDL651FS

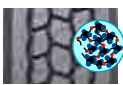

For Trucks, Drive Position

Long Haul

- **Longer Mileage and Improved Fuel Economy**
- **Good Traction and Retreadability**

Features	Advantages	Benefits
 <p>Special compound with low rolling resistance &amp; low heat generation</p>	Reduced rolling resistance with improved fuel economy	<b>Improved fuel economy and mileage</b>
 <p>Four zigzag longitudinal groove design</p>	Excellent highway traction and driving stability	<b>good traction and driving stability</b>
 <p>Closed shoulder design</p>	Provides excellent high speed performance, longer mileage and minimizes irregular shoulder wear	<b>Extended tire life</b>
 <p>Optimization block ratio</p>	Uniforms block stiffness delivers even wear and long mileage	

Size	PR	Load Index	Speed Rating	Standard Rim	Maximum Load		Maximum Pressure		Tread Depth (mm)	Outer Diameter (mm)	Section width (mm)	TL/TT
					kg	lbs	kPa	psi				
11R22.5	16PR	146/143	L	8.25	3000/2725	6610/6005	830/830	120/120	20.6	1054	279	TL
11R24.5	16PR	149/146	L	8.25	3250/3000	7160/6610	830/830	120/120	20.6	1110	279	TL
285/75R24.5	14PR	144/141	L	8.25	2800/2575	6175/5675	760/760	110/110	20.6	1056	283	TL
295/75R22.5	14PR	144/141	L	9.00	2800/2575	6175/5675	760/760	110/110	20.6	1020	298	TL

TL Tubeless Tire



Truck Series-Line Haul

# GDL633FS







For Trucks, Drive Position



Long Haul



- **Wide base Drive tire**
- **Longer Mileage and Improved Fuel Economy**
- **Good Traction and Retreadability**

Features	Advantages	Benefits
 <p>Ultra wide base with special tread compound</p>	Reduced rolling resistance for improved fuel economy and lower operating cost	<b>Lower fuel consumption and longer mileage</b>
 <p>Special sipes design</p>	Even contact pressure to minimize irregular wear	<b>Longer operating life</b>
 <p>Rugged lug pattern design</p>	Excellent drive performance and traction, with improved vehicle stability for driver confidence	<b>Better traction and safety</b>
 <p>Seven circumferential groove design</p>	Efficient water evacuation for excellent wet traction	

Size	PR	Load Index	Speed Rating	Standard Rim	Maximum Load		Maximum Pressure		Tread Depth (mm)	Outer Diameter (mm)	Section width (mm)	TL/TT
					kg	lbs	kPa	psi				
445/50R22.5	20PR	161/-	L	14.00	4625	10200	830	120	18.2	1018	445	TL

TL Tubeless Tire







Truck Series-Line Haul

# GTL922FS

SmartWay  
Verified



- **Longer Mileage**
- **Improved Fuel Consumption**

Features	Advantages	Benefits
 Four straight groove design	Enhanced driving stability and effective water evacuation properties	<b>Safety</b>
 Optimized footprint	Increased performance for wet grip	
 Continuous shoulder rib design	Provides excellent resistance to irregular wear	<b>Longer mileage &amp; Lower fuel consumption</b>
 Special tread compound	Reduced rolling resistance and improved fuel economy	

Size	PR	Load Index	Speed Rating	Standard Rim	Maximum Load		Maximum Pressure		Tread Depth (mm)	Outer Diameter (mm)	Section width (mm)	TL/TT
					kg	lbs	kPa	psi				
11R22.5	14PR	144/142	L	8.25	2800/2650	6175/5840	720/720	105/105	8.7	1054	279	TL
11R24.5	14PR	146/143	L	8.25	3000/2725	6610/6005	720/720	105/105	8.7	1104	279	TL
255/70R22.5	16PR	140/137	L	7.50	2500/2300	5510/5070	830/830	120/120	8.7	930	255	TL
285/75R24.5	14PR	144/141	L	8.25	2800/2575	6175/5675	760/760	110/110	8.7	1050	283	TL
295/75R22.5	14PR	144/141	L	9.00	2800/2575	6175/5675	760/760	110/110	8.7	1014	298	TL

TL Tubeless Tire







Truck Series-Line Haul

# GTL933FS

SmartWay  
Verified



- **Wide base Trailer tire**
- **Longer Mileage and Improved Fuel Economy**

Features	Advantages	Benefits
 <p>Ultra wide base with special tread compound</p>	Reduced rolling resistance for improved fuel economy and lower operating cost	<p><b>Lower fuel consumption and longer mileage</b></p>
 <p>Optimized sipe design on rib edges</p>	Minimized irregular wear	
 <p>Wide tread design with consistent contact patch pressure</p>	Excellent treadwear performance	<p><b>Longer operating life</b></p>
 <p>Enhanced tread groove design</p>	Effectively minimizes stone retention	

Size	PR	Load Index	Speed Rating	Standard Rim	Maximum Load		Maximum Pressure		Tread Depth (mm)	Outer Diameter (mm)	Section width (mm)	TL/TT
					kg	lbs	kPa	psi				
445/50R22.5	20PR	161/-	L	14.00	4625	10200	830	120	11.1	1018	445	TL

TL Tubeless Tire



## Truck Series – Highway & Regional

# GSR259



For trucks, Steer position







Long Haul



Regional

- **Wide Base Steer Tire • Longer Mileage**
- **Safety & Better in Handling**

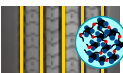

Features	Advantages	Benefits
 <p>Designed and marked COMBI ROAD</p>	Designed for usage in both traditional long haul and regional usage conditions	<b>Versatility &amp; Longer mileage</b>
 <p>Five longitudinal rib pattern design with an optimized footprint</p>	Provides high mileage and excellent handling	
 <p>New compound with for cooler running temperatures</p>	Reduces fuel consumption, while improving mileage and retreadability	
 <p>Extra wide solid shoulder design</p>	Improves vehicle stability, handling and reduces noise emissions	<b>Better stability and driving comfort</b>
 <p>Marked 3PMSF</p>	Safe winter properties	<b>Safety</b>

Size	PR	Load Index	Speed Rating	Standard Rim	Maximum Load		Maximum Pressure		Tread Depth (mm)	Outer Diameter (mm)	Section width (mm)	TL/TT
					kg	lbs	kPa	psi				
385/55R22.5	18PR	158/-(160/-)	L(K)	12.25	4250	9370	850	123	14.5	996	381	TL
385/65R22.5	20PR	164/-(160/-)	K(L)	11.75	5000	11000	900	131	15.0	1072	389	TL

TL Tubeless Tire







## Truck Series – Highway & Regional

# GSR237



### • Resist Irregular Wear • Longer Mileage & Better in handling



Features	Advantages	Benefits
 <p>Features PTD 3.0 technology, wide tread, deep grooves, large pattern pitch, angled groove wall</p>	<p>Excellent tread wear performance</p>	<p><b>Delivers Excellent mileage and longer tire life</b></p>
 <p>Designed with the ISOM simulation platform, Superior stiffness, low deformation, even force distribution, excellent contact</p>	<p>Allows for regular wear throughout tire life, minimizing damage.</p>	
 <p>Features CEM patented technology, Long-chain molecule, fine carbon black, high linkage, low heat generation</p>	<p>Delivers improved resistance to tread wear/tear and reduces overall fuel consumption</p>	
 <p>Features LCT patented curing technology, Precision melt blending, quasi-preparation, detailed molding, stable curing process</p>	<p>Provides durable casing, stronger, more flexible and resilient bead and sidewall</p>	<p><b>Stable quality and durability</b></p>

Size	PR	Load Index	Speed Rating	Standard Rim	Maximum Load		Maximum Pressure		Tread Depth (mm)	Outer Diameter (mm)	Section width (mm)	TL/TT
					kg	lbs	kPa	psi				
355/50R22.5	20PR	156	L	11.75	4000	8820	900	130	12.0	928	361	TL
295/60R22.5	18PR	150/147	L	9.00	3350/3075	7390/6780	900/900	130/130	15.0	926	292	TL
315/70R22.5	18PR	156/150 (154/150)	L(M)	9.00	4000/3350	8820/7390	900/900	130/130	15.0	1014	312	TL
275/80R22.5	18PR	149/146	M	8.25	3250/3000	7160/6610	900/900	130/130	15.8	1012	276	TL
295/80R22.5	18PR	152/149	M	9.00	3550/3250	7830/7160	900/900	130/130	16.5	1044	298	TL
10R22.5	16PR	144/142	M	7.50	2800/2650	6175/5840	900/900	130/130	15.8	1019	254	TL
11R22.5	18PR	149/146	M	8.25	3250/3000	7160/6610	930/930	135/135	16.0	1054	279	TL
12R22.5	18PR	152/149	M	9.00	3550/3250	7830/7160	930/930	135/135	17.5	1085	300	TL
9.00R20	16PR	144/142	K	7.00	2800/2650	6175/5840	900/900	130/130	15.8	1019	259	TL
10.00R20	18PR	149/146	K	7.50	3250/3000	7160/6610	930/930	135/135	16.0	1054	278	TL

TL Tubeless Tire

**Truck Series – Highway & Regional  
Light Truck Series – Regular Transport**

# GSR225



For trucks, steer / All position



Light Truck, All position









Long Haul

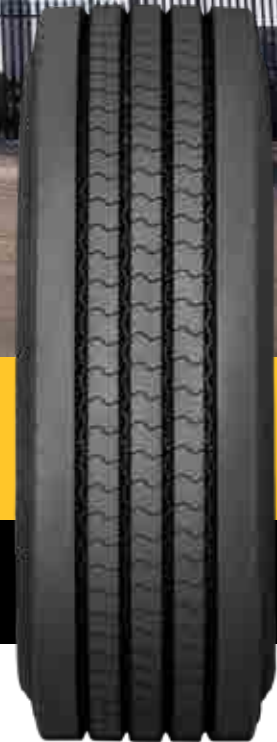

Regional

- Resist Irregular Wear • Longer Mileage
- Better in Handling

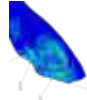

Features	Advantages	Benefits
 <p>Four belt construction</p>	Increases casing and tread stiffness, minimizing tire deformation for longer wear	<b>Delivers longer mileage</b>
 <p>Widened tread layout</p>	Large tread volume foreextended wear life	
 <p>Giti specially-formulated tread compound</p>	Improved wear resistance of tread	
 <p>Resilient four vertical groove and zig-zag bottom design</p>	Provides better handling and controllability of vehicle	<b>Improved stability and driving comfort</b>
 <p>Multiple sipes along the side of groove</p>	Self cleaning capability and higher resistance to damage from road hazards	<b>Extended tire life</b>
 <p>FEA bead construction optimization concept for bead construction</p>	Optimizes and uniformly distributes load pressure to the bead, minimizing damage	

Size	PR	Load Index	Speed Rating	Standard Rim	Maximum Load		Maximum Pressure		Tread Depth (mm)	Outer Diameter (mm)	Section width (mm)	TL/TT
					kg	lbs	kPa	psi				
11R22.5	16PR	148/145	M	8.25	3150/2900	6940/6395	850/850	123/123	15.3	1054	279	TL
12R22.5	18PR	152/149	L	9.00	3550/3250	7830/7160	930/930	135/135	15.8	1085	300	TL
225/70R19.5	14PR	128/126	L	6.75	1800/1700	3970/3750	760/760	110/110	13.0	811	226	TL
245/70R19.5	16PR	136/134	M	7.50	2240/2120	4940/4675	830/830	120/120	14.0	839	248	TL
245/70R19.5	18PR	141/140	M	7.50	2575/2500	5675/5510	860/860	125/125	14.0	839	248	TL
265/70R19.5	16PR	140/138	M	7.50	2500/2360	5510/5205	790/790	115/115	14.0	867	262	TL
275/70R22.5	18PR	148/145 (152/148)	M(J)	8.25	3150/2900	6945/6395	900/900	130/130	15.0	958	276	TL
285/70R19.5	16PR	146/145	M	8.25	3000/2900	6610/6395	900/900	130/130	14.5	895	283	TL
295/60R22.5	18PR	150/147	L	9.00	3350/3075	7390/6780	900/900	131/131	15.0	926	292	TL
295/80R22.5	18PR	154/149	M	9.00	3750/3250	8270/7160	850/850	123/123	16.5	1044	298	TL
305/70R22.5	20PR	154/150	L	9.00	3750/3350	8270/7390	900/900	131/131	15.5	1000	305	TL
315/60R22.5	20PR	154/148	L	9.75	3750/3150	8270/6940	900/900	131/131	13.5	950	313	TL
315/70R22.5	20PR	156/150 (154/150)	L(M)	9.00	4000/3350	8820/7390	900/900	131/131	15.5	1014	312	TL
315/80R22.5	20PR	158/150 (154/150)	L(M)	9.00	4250/3350	9370/7390	900/900	131/131	16.8	1076	312	TL

## Truck Series – Highway & Regional

# GSW226



For trucks, Steer position



Long Haul



Regional

### • Superb Winter Properties • Safety & Stability



M + S

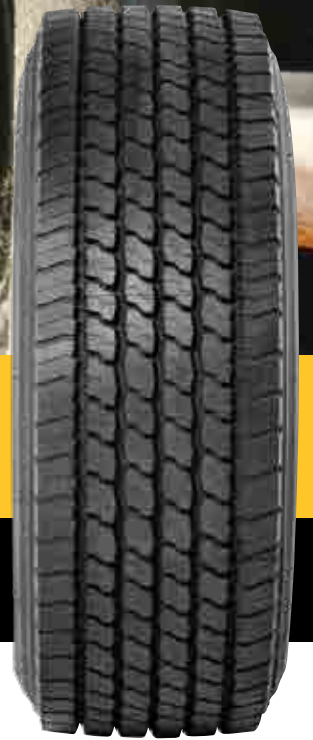

Features	Advantages	Benefits
<p>Pattern design with many deep sipes</p>	Provides excellent steering and braking performances in the most severe winter conditions	<b>Better handling in severe winter condition</b>
<p>Rib pattern design with an optimized footprint</p>	Provides highest level of sideforces for best steering properties in winter conditions	
<p>Optimized tread pattern layout</p>	Improves driver comfort	<b>Excellent stability and driving comfort</b>
<p>Wide shoulder ribs</p>	Optimum stability and driver comfort	
<p>Achieves 3PMSF performance requirement</p>	Meets legal requirements for 3PMSF certified winter tyres	<b>Safety</b>

Size	PR	Load Index	Speed Rating	Standard Rim	Maximum Load		Maximum Pressure		Tread Depth (mm)	Outer Diameter (mm)	Section width (mm)	TL/TT
					kg	lbs	kPa	psi				
315/70R22.5	18PR	156/150 (154/150)	L(M)	9.00	4000/3350	8820/7390	900/900	131/131	15.5	1014	312	TL
315/80R22.5	18PR	158/150 (154/150)	L(M)	9.00	4250/3350	9370/7390	900/900	131/131	16.8	1076	312	TL
385/55R22.5	18PR	158/-(160/-)	L(J)	12.25	4250	9370	850	123	15.5	996	386	TL
385/65R22.5	20PR	164/-(160/-)	K(L)	11.75	5000	11000	900	131	16.0	1072	389	TL

TL Tubeless Tire



Truck Series – Highway & Regional

# GSR231FS







For trucks, All position



Regional



- **Longer Mileage and Improved Fuel Economy**
- **Good Anti-scrubbing and Retreadability**

Features	Advantages	Benefits
 <p>Special compound with low heat generation &amp; longer wear</p>	Provide higher tire mileage and improved fuel economy	<b>Improved fuel economy and mileage</b>
 <p>Four groove design</p>	Enhanced tread stiffness, reduce in rolling resistance, reliable control and handling	<b>Better Stability and driving comfort</b>
 <p>Multiple sipes on ribs</p>	Optimum traction & braking	<b>Extended tire life</b>
 <p>Optimized footprint distribution</p>	Improves footprint performance to prevent irregular wear	

Size	PR	Load Index	Speed Rating	Standard Rim	Maximum Load		Maximum Pressure		Tread Depth (mm)	Outer Diameter (mm)	Section width (mm)	TL/TT
					kg	lbs	kPa	psi				
295/75R22.5	14PR	144/141	L	9.00	2800/2575	6175/5675	760/760	110/110	16.7	1014	298	TL
11R22.5	14PR	144/142	L	8.25	2800/2650	6175/5840	720/720	105/105	16.7	1054	279	TL
11R22.5	16PR	148/145	L	8.25	3150/2900	6940/6395	850/850	123/123	16.7	1054	279	TL

TL Tubeless Tire





Truck Series – Highway & Regional

# GAR868S





For trucks, All position



Regional

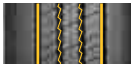

- **Longer mileage**
- **Strengthened loading capability**

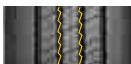
Features	Advantages	Benefits
 <p>5 rib 4 wide straight groove design</p>	Better resistance to wet-sliding with even tread wear and comfortable drive-handling	<b>Longer mileage</b>
<p>Special tread compound</p>	Low heat generation and superb resistance to abrasion	
 <p>Crossing sipe in intermediate rib and anti stone trapping design</p>	Enhanced traction and tread life	<b>Strengthened durability &amp; loading capability</b>
 <p>Reinforced casing and bead structure</p>	Improved tire damage resistance in heavy load operating conditions	

Size	PR	Load Index	Speed Rating	Standard Rim	Maximum Load		Maximum Pressure		Tread Depth (mm)	Outer Diameter (mm)	Section width (mm)	TL/TT
					kg	lbs	kPa	psi				
11.00R20	18PR	152/149	K	8.00	3550/3250	7830/7160	930/930	135/135	15.0	1085	293	TT

TT Tube Type Tire



## Truck Series – Highway & Regional

# GAR827







For trucks, All position



Regional

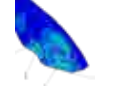

### • Longer Tire Life • Optimized Bead Construction

Features	Advantages	Benefits
 <p>Tough compound with deeper tread depth</p>	Provides good protection and long mileage in versatile condition	<b>Delivers longer mileage</b>
 <p>Three zig-zag groove design</p>	Provides better controllability and better resistance against road damages	<b>Safety &amp; Extended tire life</b>
 <p>Optimized bead structure</p>	High bead durability	<b>Extended tire life</b>
 <p>FEA bead construction optimization concept for bead construction</p>	Optimizes and uniformly distributes load pressure to the bead, minimizing damage	
 <p>Rib and block arrangement with solid shoulder</p>	Suitable for various regional and light on/off road conditions	
 <p>Retread Tire casing designed for retreadability</p>	Higher retreadable capabilities	

Size	PR	Load Index	Speed Rating	Standard Rim	Maximum Load		Maximum Pressure		Tread Depth (mm)	Outer Diameter (mm)	Section width (mm)	TL/TT
					kg	lbs	kPa	psi				
11.00R20	16PR	150/147	K	8.00	3350/3075	7390/6780	830/830	120/120	17.2	1085	293	TT
11R22.5	16PR	148/145	K	8.25	3150/2900	6940/6395	850/850	123/123	17.2	1054	279	TL
275/70R22.5	16PR	148/145	K	8.25	3150/2900	6945/6395	900/900	130/130	18.5	958	276	TL

TL Tubeless Tire TT Tube Type Tire

Truck Series – Highway & Regional

# GAR558/GAR558+







For trucks, All position



Regional



- **Longer operating life • Irregular Wear Resistant**
- **Excellent Durability & Damage Resistant**

Features	Advantages	Benefits
 <p>Four belt construction</p>	Effectively optimizes crown stiffness and tire contact surface pressure, promoting long wear life	<b>Longer operating life</b>
 <p>Special wear-resistant compound</p>	Promotes long wear life	
 <p>Optimal rib ratio and rigidity of tread pattern</p>	Equalizes distribution of tire contact surface pressure, preventing tire from irregular wear	
 <p>Big groove wall design and Anti-stone trapping groove bottom</p>	Effectively prevents stone trapping, protecting the tire from road hazards	<b>Excellent Durability &amp; Damage Resistant</b>
 <p>Shoulder void design and zigzag longitudinal groove</p>	Provides effective heat dissipation and better resistance against damages	

Size	PR	Load Index	Speed Rating	Standard Rim	Maximum Load		Maximum Pressure		Tread Depth (mm)	Outer Diameter (mm)	Section width (mm)	TL/TT
					kg	lbs	kPa	psi				
8.25R20	16PR	139/137	K	6.50	2430/2300	5355/5070	930/930	135/135	14.0	974	236	TT
9.00R20	16PR	144/142	K	7.00	2800/2650	6175/5840	900/900	130/130	14.5	1019	259	TT
10.00R20	18PR	149/146	K	7.50	3250/3000	7160/6610	930/930	135/135	15.0	1054	278	TT
11.00R20	18PR	152/149	K	8.00	3550/3250	7830/7160	930/930	135/135	15.3	1085	293	TT
9R22.5	14PR	136/134	M	6.75	2240/2120	4940/4675	830/830	120/120	14.0	974	229	TL
10R22.5	16PR	144/142	M	7.50	2800/2650	6175/5840	900/900	130/130	14.8	1019	254	TL
11R22.5	16PR	148/145	M	8.25	3150/2900	6940/6395	850/850	123/123	15.8	1054	279	TL
★ 12R22.5	18PR	152/149	M	9.00	3550/3250	7830/7160	930/930	135/135	16.3	1085	300	TL

TL Tubeless Tire TT Tube Type Tire

★ GAR558+





Truck Series – Highway & Regional

# GDL617



• Longer Mileage • Lower Fuel Consumption • Excellent Traction

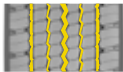

Features	Advantages	Benefits
 <p>Wide tread pattern design</p>	Increases mileage, traction and driver comfort through high level of stability	<b>Longer mileage &amp; Better traction and driving comfort</b>
 <p>Optimal tread depth for long haul applications</p>	Reduces fuel consumption while delivering excellent mileage	<b>Longer mileage &amp; Lower fuel consumption</b>
 <p>Achieves 3PMSF performance requirement</p>	Meets legal requirements for 3PMSF certified winter tyres	<b>Safety</b>

Size	PR	Load Index	Speed Rating	Standard Rim	Maximum Load		Maximum Pressure		Tread Depth (mm)	Outer Diameter (mm)	Section width (mm)	TL/TT
					kg	lbs	kPa	psi				
295/60R22.5	18PR	150/147 (149/146)	K(L)	9.00	3350/3075	7390/6780	900/900	131/131	18.2	932	292	TL
315/60R22.5	18PR	152/148	L	9.75	3550/3150	7830/6940	900/900	131/131	18.2	950	313	TL
315/80R22.5	18PR	156/150 (154/150)	L(M)	9.00	4000/3350	8820/7390	850/850	123/123	18.2	1076	312	TL

TL Tubeless Tire



Truck Series – Highway & Regional

# GDR675



- Outstanding mileage and traction
- Safe and comfortable



Features	Advantages	Benefits
<p>Giti specially formulated tread compound</p>	Improved wear resistance of tread	Provide outstanding mileage and traction
<p>Directional tread pattern design with Interconnected big central block</p>	Create a synergistic effect to enhance tread stiffness and control deformation	
<p>3D sipes technology</p>	Optimized pattern rigidity with uniform force distribution on tread	
<p>Variable tie-bar dimension</p>	Reduces tire rolling noise and optimizes stiffness and tread robustness	Safe and comfortable
<p>Narrow central circumferential grooves embedded with stone ejector</p>	Excellent driving properties and higher protection for the casing	Longer operation life

Size	PR	Load Index	Speed Rating	Standard Rim	Maximum Load		Maximum Pressure		Tread Depth (mm)	Outer Diameter (mm)	Section width (mm)	TL/TT
					kg	lbs	kPa	psi				
315/70R22.5	18PR	154/150 (152/148)	L(M)	9.00	3750/3350	8270/7390	900/900	130/130	19.0	1014	312	TL
315/60R22.5	18PR	152/148	L	9.75	3550/3150	7830/6940	900/900	130/130	18.0	950	313	TL
295/80R22.5	18PR	152/149	M	9.00	3550/3250	7830/7160	900/900	130/130	20.0	1044	298	TL
315/80R22.5	18PR	156/150 (154/150)	L(M)	9.00	4000/3350	8820/7390	850/850	123/123	20.0	1076	312	TL

TL Tubeless Tire









## Truck Series – Highway & Regional

# GDR665



- **Superior Traction**
- **Longer Mileage**

Features	Advantages	Benefits
 <p>Specially arranged block and sipe angle</p>	Enhanced traction driving performance	<p><b>Better traction and braking</b></p> <p><b>Delivers longer mileage</b></p>
 <p>Four belt construction</p>	Increases casing and tread stiffness, minimizing tire deformation for longer wear	
 <p>Advanced Equal Force Casing technology</p>	Uniform force distribution enables optimal tire footprint at various loads level thus result in regular tread wear.	
 <p>Widened tread width design</p>	Large tread volume area for extended wear life	
 <p>Extended tread depth</p>	Higher tread volume for longer mileage driving capabilities	
 <p>Giti specially formulated tread compound</p>	Improved wear resistance of tread	
 <p>Directional deep tread pattern design</p>	Delivers excellent traction, provides optimal mileage performance and reduces irregular wear	

Size	PR	Load Index	Speed Rating	Standard Rim	Maximum Load		Maximum Pressure		Tread Depth (mm)	Outer Diameter (mm)	Section width (mm)	TL/TT
					kg	lbs	kPa	psi				
295/80R22.5	18PR	152/149	M	9.00	3550/3250	7830/7160	900/900	130/130	21.1	1044	298	TL
315/80R22.5	18PR	156/150 (154/150)	L(M)	9.00	4000/3350	8820/7390	850/850	123/123	21.0	1076	312	TL

TL Tubeless Tire

## Truck Series – Highway & Regional

# GDR655/GDR655+



For trucks, Drive position







Long Haul



Regional

## • Superior Traction • Longer Mileage

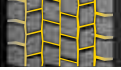
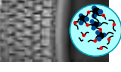

Features	Advantages	Benefits
 <p>Specially arranged block and sipe angle</p>	Enhanced traction driving performance	<b>Better traction and braking</b>
 <p>Four belt construction</p>	Increases casing and tread stiffness, minimizing tire deformation for longer wear	
 <p>Widened tread width design</p>	Large tread volume area for extended wear life	<b>Delivers longer mileage</b>
 <p>Extended tread depth</p>	Higher tread volume for longer mileage driving capabilities	
 <p>Giti specially-formulated tread compound</p>	Improved wear resistance of tread	
 <p>Uniquely designed inter-dependant blocks at of tread pattern center</p>	Limits block movement, effectively reducing abnormal wear	
 <p>FEA bead construction optimization concept for bead construction</p>	Optimizes and uniformly distributes load pressure to the bead, minimizing damage	<b>Extended tire life</b>

Size	PR	Load Index	Speed Rating	Standard Rim	Maximum Load		Maximum Pressure		Tread Depth (mm)	Outer Diameter (mm)	Section width (mm)	TL/TT
					kg	lbs	kPa	psi				
11R22.5	16PR	148/145	M	8.25	3150/2900	6940/6395	850/850	123/123	21.0	1050	279	TL
295/80R22.5	18PR	152/149	M	9.00	3550/3250	7830/7160	900/900	130/130	21.1	1044	298	TL
315/70R22.5	20PR	154/150 (152/148)	L(M)	9.00	3750/3350	8270/7390	900/900	131/131	21.0	1014	312	TL
315/80R22.5	18PR	156/150 (154/150)	L(M)	9.00	4000/3350	8820/7390	850/850	123/123	21.0	1076	312	TL
★ 295/80R22.5	18PR	152/149	M	9.00	3550/3250	7830/7160	900/900	130/130	21.1	1044	298	TL

TL Tubeless Tire

★ GDR655+



## Truck Series – Highway & Regional

# GDR621/GDR621+







For trucks, Drive position



Regional

### • Longer Mileage • Excellent Traction & Winter Properties



Features	Advantages	Benefits
 <p>Wide tread pattern with advanced block and sipe design</p>	Provides excellent traction and winter driving properties	<b>Better traction &amp; handling in severe winter condition</b>
 <p>New casing construction combined with very deep tread depth</p>	Provides an optimal footprint, excellent wear pattern with a high mileage potential	<b>Longer mileage</b>
 <p>Optimized pattern and shoulder design</p>	Provides excellent driving comfort	<b>Excellent driving comfort</b>
 <p>Achieves 3PMSF performance requirement</p>	Meets legal requirements for 3PMSF certified winter tyres	<b>Safety</b>

Size	PR	Load Index	Speed Rating	Standard Rim	Maximum Load		Maximum Pressure		Tread Depth (mm)	Outer Diameter (mm)	Section width (mm)	TL/TT
					kg	lbs	kPa	psi				
11R22.5	16PR	148/145	L	8.25	3150/2900	6940/6395	850/850	123/123	21.4	1054	279	TL
11R24.5	16PR	149/146	L	8.25	3250/3000	7160/6610	830/830	120/120	21.4	1104	279	TL
315/80R22.5	20PR	158/150 (154/150)	L(M)	9.00	4250/3350	9370/7390	900/900	130/130	23.1	1076	312	TL
★ 315/70R22.5	18PR	154/150 (152/148)	L(M)	9.00	3750/3350	8270/7390	900/900	131/131	21.0	1014	312	TL
★ 315/80R22.5	20PR	154/150 (152/148)	L(M)	9.00	4250/3350	9370/7390	900/900	130/130	23.1	1076	312	TL

TL Tubeless Tire

★ GDR621+









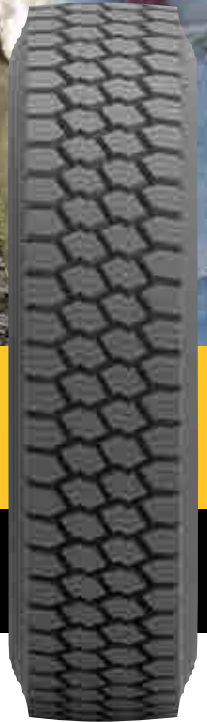

Truck Series – Highway & Regional

# GDW628

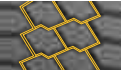

- **Excellent Snow traction**
- **Longer mileage and higher durability**



Features	Advantages	Benefits	
 Wide-angle longitudinal/transverse zigzag grooves  Polygonal Blocks with sharp edge design  Different depth sipes on the blocks	Offers excellent traction on snow covered roads Promote tire's snow embedding performance High traction & braking on wet and dry surfaces	<b>Excellent traction and braking performance</b>	
 Tire-bar between blocks with sipes design  Open-shoulder with "trumpet" type design  Special tread compound suitable for all seasons	Prevents heel & toe irregular wear Allows mud and slush evacuation through the open shoulder grooves Offers good wear performance and cutting resistance		<b>Delivers Longer mileage &amp; better damage resistant</b>

Size	PR	Load Index	Speed Rating	Standard Rim	Maximum Load		Maximum Pressure		Tread Depth (mm)	Outer Diameter (mm)	Section width (mm)	TL/TT
					kg	lbs	kPa	psi				
11R22.5	16PR	148/145	L	8.25	3150/2900	6940/6395	850/850	123/123	20.6	1059	279	TL
11R24.5	16PR	149/146	L	8.25	3250/3000	7160/6610	830/830	120/120	20.6	1110	279	TL

TL Tubeless Tire

## Truck Series – Highway & Regional

# GDR688







For trucks, Drive position

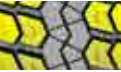

Regional

### • Excellent Traction • Longer Mileage



Features	Advantages	Benefits
 Open shoulder aggressive lug pattern  Dual serrated elements in the centre block of pattern	Provides excellent all-season traction  Provides exceptional stability and additional traction	<b>Better traction and braking</b>
 Optimized tread pattern arrangement with unique shoulder block  Special wear-resistant compound	Promote regular wear  Promotes long wear-resistant performance	

Size	PR	Load Index	Speed Rating	Standard Rim	Maximum Load		Maximum Pressure		Tread Depth (mm)	Outer Diameter (mm)	Section width (mm)	TL/TT
					kg	lbs	kPa	psi				
10R22.5	16PR	144/142	M	7.50	2800/2650	6175/5840	850/850	123/123	15.8	1019	254	TL
11R22.5	16PR	148/145	M	8.25	3150/2900	6940/6395	850/850	123/123	17.2	1050	279	TL
12R22.5	16PR	152/148	M	9.00	3550/3150	7830/6940	850/850	123/123	17.2	1085	300	TL

TL Tubeless Tire







Truck Series – Highway & Regional

# GDR652

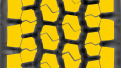

## • Longer Mileage • Superior Traction and Retreadability

Features	Advantages	Benefits
 <p>Wide and deeper tread pattern</p>	Larger tread volume for longer mileage	<b>Improved fuel economy</b>
 <p>Rationalized block stiffness distribution</p>	Excellent performance in irregular wear resistance	<b>Deliver longer mileage</b>
 <p>Open block design</p>	Effectively prevents occurrence of “heel & toe”	
 <p>Open shoulder design</p>	Provides good traction performance with improved heat dissipation and endurance performance	<b>Better traction</b>

Size	PR	Load Index	Speed Rating	Standard Rim	Maximum Load		Maximum Pressure		Tread Depth (mm)	Outer Diameter (mm)	Section width (mm)	TL/TT
					kg	lbs	kPa	psi				
295/75R22.5	14PR	144/141	L	9.00	2800/2575	6175/5675	760/760	110/110	23.8	1026	298	TL
11R22.5	16PR	148/145	L	8.25	3150/2900	6940/6395	850/850	123/123	23.8	1065	279	TL
11R24.5	14PR	146/143	L	8.25	3000/2725	6610/6005	720/720	105/105	23.8	1116	279	TL
11R24.5	16PR	149/146	L	8.25	3250/3000	7160/6610	830/830	120/120	23.8	1116	279	TL

TL Tubeless Tire

## Truck Series – Highway & Regional

# GTL919/GTL919+







For trucks, Trailer position



Long Haul

### • Longer Mileage • Lower Fuel Consumption • Safety



Features	Advantages	Benefits
 <p>New generation pattern featuring new groove design and extra wide shoulder</p>	Provides good protection in shoulder area and very regular wear	Longer operating life
 <p>New casing construction</p>	Improves casing stiffness and footprint, resulting in longer tyre life	
 <p>Dedicated compound formula for long distance usage</p>	Reduce fuel consumption while providing high mileage	Longer mileage & Lower fuel consumption
 <p>Marked 3PMSF</p>	Safe winter properties	Safety

Size	PR	Load Index	Speed Rating	Standard Rim	Maximum Load		Maximum Pressure		Tread Depth (mm)	Outer Diameter (mm)	Section width (mm)	TL/TT
					kg	lbs	kPa	psi				
215/75R17.5	16PR	135/133	J	6.00	2180/2060	4805/4540	860/860	125/125	12.5	767	211	TL
235/75R17.5	16PR	143/141 (146/146)	J(F)	6.75	2725/2575	6005/5675	860/860	125/125	13.0	797	233	TL
245/70R17.5	16PR	143/141 (146/146)	J(F)	7.50	2725/2575	6005/5675	875/875	127/127	13.0	789	248	TL
245/70R19.5	18PR	141/140	J	7.50	2575/2500	5675/5510	860/860	125/125	14.0	839	248	TL
265/70R19.5	18PR	143/141	J	7.50	2725/2575	6005/5675	850/850	123/123	14.5	867	262	TL
285/70R19.5	18PR	150/148	J	8.25	3350/3150	7390/6940	900/900	130/130	14.0	895	283	TL
385/55R22.5	20PR	160/- (158/-)	K(L)	12.25	4500	9920	900	131	14.8	996	386	TL
385/65R22.5	20PR	164/- (158/-)	K(L)	11.75	5000	11000	900	130	15.5	1072	389	TL
425/65R22.5	20PR	165/-	K	12.25	5150	11400	830	120	15.3	1124	422	TL
★ 385/65R22.5	20PR	164/- (158/-)	K(L)	11.75	5000	11000	900	130	15.5	1072	389	TL

TL Tubeless Tire

★ GTL919+







**Truck Series – Highway & Regional**

# GTL925



- **Longer Mileage • Lower Fuel Consumption**
- **Excellent damage resistant**



Features	Advantages	Benefits
 <p>Extra wide rib tread pattern design</p>	Provides very regular wear across total tread width with high mileage potential	<b>Longer mileage</b>
 <p>Wide shoulders with wear stabilizing outer groove features</p>	Protects casing from impact damages to the shoulder area	<b>Excellent damage resistant</b>
 <p>Optimized compound and casing construction</p>	Reduction in overall fuel consumption and casing fatigue	<b>Lower fuel consumption</b>
 <p>Marked 3PMSF</p>	Safe winter properties	<b>Safety</b>

Size	PR	Load Index	Speed Rating	Standard Rim	Maximum Load		Maximum Pressure		Tread Depth (mm)	Outer Diameter (mm)	Section width (mm)	TL/TT
					kg	lbs	kPa	psi				
435/50R19.5	20PR	164	J	14.00	5000	11000	900	131	12.9	931	438	TL
445/45R19.5	22PR	164	J	14.00	5000	11000	900	131	12.9	895	436	TL

TL Tubeless Tire





Truck Series – Highway & Regional

# GTR926

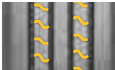

- **Dedicated Design for Trailer Use • Longer Mileage**
- **Good Retreadability**

Features	Advantages	Benefits
 <p>Four straight grooves design</p>	<p>Provides good high speed and drainage performance Low roll resistance and lower fuel consumption</p>	<p><b>Longer Mileage and high speed stability</b></p>
 <p>Sipe design</p>	<p>Provide good grip performance</p>	<p><b>Low Rolling resistance for better fuel economy and environment friendly</b></p>
 <p>Large angle design is adopted for pattern groove</p>	<p>Effectively improve the self-cleaning function of tires, prevention of stones trapping Raise wear performance</p>	<p><b>Suitable For trailer position on Regional and Urban Roads</b></p>

Size	PR	Load Index	Speed Rating	Standard Rim	Maximum Load		Maximum Pressure		Tread Depth (mm)	Outer Diameter (mm)	Section width (mm)	TL/TT
					kg	lbs	kPa	psi				
315/80R22.5	18PR	156/150	M	9.00	4000/3350	8820/7390	850/850	123/123	13.0	1076	312	TL

TL Tubeless Tire



Truck Series – Highway & Regional

# GTR923



• **Longer Operating Life** • **Better Damage Resistant**



Features	Advantages	Benefits
<p>Robust block design with connecting tie bars</p>	Protects the casing while delivering excellent regular wear properties and high mileage performance	<b>Longer operating life</b>
<p>Special anti cut and chip compound</p>	Highly suitable for usage in aggressive timber and milk transportation conditions	
<p>Extra deep groove design with stone ejection system</p>	Reduces the risk of stone drilling into the casing	<b>Better damage resistant</b>
<p>Achieves 3PMSF performance requirement</p>	Meets legal requirements for 3PMSF certified winter tyres	<b>Safety</b>

Size	PR	Load Index	Speed Rating	Standard Rim	Maximum Load		Maximum Pressure		Tread Depth (mm)	Outer Diameter (mm)	Section width (mm)	TL/TT
					kg	lbs	kPa	psi				
265/70R19.5	18PR	143/141	J	7.50	2725/2575	6005/5675	850/850	123/123	14.5	867	262	TL

TL Tubeless Tire



Truck Series – Off/On Road

# GAO822

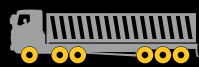

Dumper trailer ,All position



Dumper ,All position







Cement Mixer ,All position

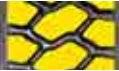

Off Road

- High Traction for Off-Road Usage
- Durability & Extended Service Life

Features	Advantages	Benefits
 <p>Aggressive block pattern and open shoulder design</p>	Provides high traction, with self-cleaning performance	<b>Better traction and braking</b>
 <p>Deep tread pattern design</p>	Provide longer tire service life	
 <p>Tie-bar design between center blocks</p>	Effectively prevents pattern blocks from tearing	<b>Extended tire life</b>
 <p>Reinforced casing and bead structure</p>	Improves durability of casing and bead, and increasing tire damage resistance in heavy load operating conditions	
 <p>Specially formulated tread compound</p>	Provides strong cut and chip resistance on tough off road conditions	

Size	PR	Load Index	Speed Rating	Standard Rim	Maximum Load		Maximum Pressure		Tread Depth (mm)	Outer Diameter (mm)	Section width (mm)	TL/TT
					kg	lbs	kPa	psi				
8.25R20	16PR	139/137	F	6.50	2430/2300	5355/5070	930/930	135/135	18.7	986	236	TT
11.00R20	18PR	152/149	F	8.00	3550/3250	7830/7160	930/930	135/135	23.5	1096	293	TT
12.00R20	20PR	156/153	F	8.50	4000/3650	8820/8050	900/900	130/130	24.5	1136	315	TT
12R22.5	18PR	152/149	F	9.00	3550/3250	7830/7160	930/930	135/135	23.5	1096	300	TL
295/80R22.5	18PR	152/149	J	9.00	3550/3250	7830/7160	900/900	130/130	21.0	1050	298	TL
12.00R24	20PR	160/156	F	8.50	4500/4000	9920/8820	850/850	123/123	31.0	1226	313	TT

TL Tubeless Tire TT Tube Type Tire





Truck Series – Off/On Road

# GAO852

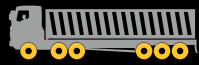

Dumper trailer ,All position



Dumper ,All position









Cement Mixer ,All position

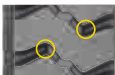

Off Road

- High Traction for Off-Road Usage
- Durable & Extended Service Life

Features	Advantages	Benefits
 Reinforced belt construction	Protects casing from external punctures and delivers strong resistance against tread bursting	<b>Extended tire life</b>
 Reinforced casing and bead structure	Improves durability of casing and bead, increasing damage resistance from heavy load operating conditions	
 Sidewall protection rib	Protects sidewall from road hazard and curbing damage	
 Unique groove width design	Protects tire and groove from stone trapping and offer good self cleaning properties to prevent tire damages	
 Tie-bar design between center blocks	Improve block rigidity and prevents pattern blocks from tearing	
 Type-Z shape block pattern design	Provides maximum biting edge for excellent traction and braking force	<b>Better traction and braking</b>
 Anti-Cut and Chip compound developed for mixed conditions of working in the mine and delivers materials out of mine services	Provides excellent protection from tread cuts and chips in aggressive road condition while promote long wear life	<b>Delivers longer mileage</b>

Size	PR	Load Index	Speed Rating	Standard Rim	Maximum Load		Maximum Pressure		Tread Depth (mm)	Outer Diameter (mm)	Section width (mm)	TL/TT
					kg	lbs	kPa	psi				
11.00R20	18PR	152/149	F	8.00	3550/3250	7830/7160	930/930	135/135	24.0	1096	293	TT
12.00R20	20PR	156/153	F	8.50	4000/3650	8820/8050	900/900	130/130	24.0	1136	315	TT

TT Tube Type Tire









Truck Series – Off/On Road  
Light Truck Series – Dumper

# GAO829

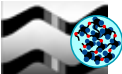

- High Traction for Off-Road Usage
- Durability & Extended Service Life

Features	Advantages	Benefits
 <p>Giti Specially reinforced bead structure</p>	Improves durability of casing and bead, and increasing tire damage resistance in heavy load operating conditions	Extended tire life
 <p>Reinforced sidewall and casing</p>	Protects tire and groove from stone trapping and offer good self cleaning properties to prevent tire damages	
 <p>Specially formulated tread Compound for bad road</p>	Provides excellent protection from tread cuts and chips in aggressive road condition while promote long wear life	
 <p>Tie-bar design between blocks</p>	Improves block rigidity and prevents pattern blocks from tearing	
 <p>Type-Z shape block pattern design</p>	Provides maximum biting edge for excellent traction and braking force	Better traction and braking
 <p>Lateral grooves with wide angles</p>	Protects tire and groove from stone trapping and offer good self cleaning properties to prevent tire damages	

Size	PR	Load Index	Speed Rating	Standard Rim	Maximum Load		Maximum Pressure		Tread Depth (mm)	Outer Diameter (mm)	Section width (mm)	TL/TT
					kg	lbs	kPa	psi				
7.00R16	14PR	118/114	F	5.50F	1320/1180	2910/2600	770/770	110/110	15.5	785	200	TT
7.50R16	14PR	122/118	F	6.00G	1500/1320	3305/2910	770/770	110/110	16.0	805	215	TT
8.25R16	16PR	128/124	F	6.50H	1800/1600	3970/3530	770/770	110/110	16.8	855	235	TT
8.25R20	16PR	139/137	F	6.50	2430/2300	5355/5070	930/930	135/135	19.0	986	236	TT
9.00R20	16PR	144/142	F	7.00	2800/2650	6175/5840	900/900	130/130	22.0	1030	259	TT
10.00R20	18PR	149/146	F	7.50	3250/3000	7160/6610	930/930	135/135	22.5	1065	278	TT
11.00R20	18PR	152/149	F	8.00	3550/3250	7830/7160	930/930	135/135	23.0	1096	293	TT
12.00R20	20PR	156/153	F	8.50	4000/3650	8820/8050	900/900	130/130	23.5	1136	315	TT





Truck Series – Off/On Road

# GAO897

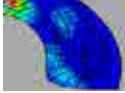
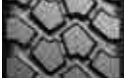

- **High mobility under all road conditions**
- **Well applicable under all season, temperature ranging 55 °C to -40 °C**

Features	Advantages	Benefits
 <p>Waved pattern block design</p>	High mobility on all road conditions, Good grip performance under both dry and wet road condition; Adjustable air pressure to different road conditions	<p><b>Applicable for all road and all season condition</b></p>
 <p>All-steel radial tire with high strength structure</p>	Enhances rigidity for tire casing and improves load capability	
 <p>Top-class compound applied to the severe climates and bad road conditions</p>	Excellent durability under very low or high temperature while providing cut & chip and wear resistance	
 <p>Optimized bead contour and material distribution</p>	Excellent sealing performance ensured by the tight seating to the rim under the low pressure	
 <p>Elevated tie bar and arched groove bottom design</p>	Enhances pattern block rigidity and improves tear resistance	<p><b>Longer operating life</b></p>

Size	PR	Load Index	Speed Rating	Standard Rim	Maximum Load		Maximum Pressure		Tread Depth (mm)	Outer Diameter (mm)	Section width (mm)	TL/TT
					kg	lbs	kPa	psi				
14.00R20	20PR	164/161	J	10.00	5000/4625	11000/10200	790/790	115/115	23.0	1253	375	TL

TL Tubeless Tire







Truck Series – Off/On Road

# GAO898

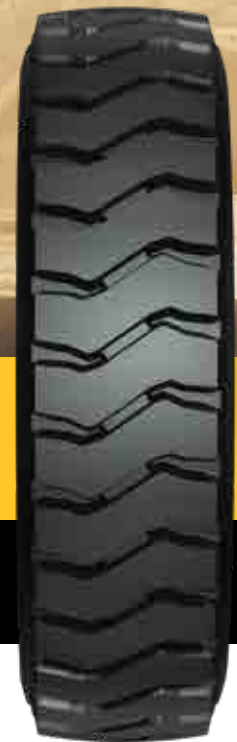

- **Super anti-cut and anti-puncture**
- **Stronger Load Capability**



Features	Advantages	Benefits
 <p>Special compound for tread and sidewall</p>	Outstanding performance on cut&ship resistance	<b>Excellent damage resistant</b>
 <p>4 belt structure and improved footprint, Strong casing with tensile cord structure inside</p>	Enhanced load carrying capability for more efficient transportation	<b>Good load carrying capability and excellent traction on aggressive road conditions</b>
 <p>Widened pattern block and deeper base rubber compound</p>	Super driving and grip performance	
 <p>Reinforced tire bar design between blocks</p> <p>Widened tread width and improved side anti-scratch line design</p>	Enhance overall rigidity <p>Large tread volume area and better resistance to the impact of external scratches</p>	<b>Longer operating life</b>

Size	PR	Load Index	Speed Rating	Standard Rim	Maximum Load		Maximum Pressure		Tread Depth (mm)	Outer Diameter (mm)	Section width (mm)	TL/TT
					kg	lbs	kPa	psi				
14.00R25	-	-	-	10.00/2.0	10000/5800	22000/12800	950/700	138/102	26.0	1370	375	TT

TT Tube Type Tire



Truck Series – On/Off Road

# GAM851

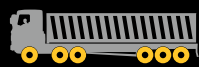
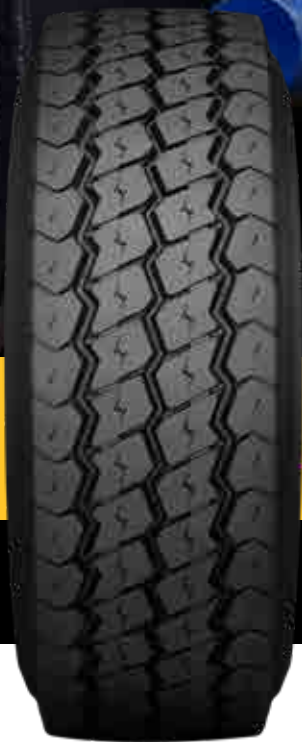

Dumper trailer ,All position



Dumper ,All position





Cement Mixer ,All position

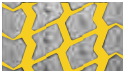
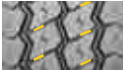

Mixed Service

## • Longer Operating Life • Safety

Features	Advantages	Benefits
 <p>Deep tread design with special anti cut and chip compound</p>	<p>Superb resistance to tread tearing, impacts and casing damages in on/off road conditions</p>	<p><b>Longer operating life</b></p>
 <p>Compact three groove design connected with multiple tie bars</p>	<p>Provides very regular wear and reduce noise levels</p>	
 <p>New casing construction</p>	<p>Regular wear throughout the life of the tyre delivering excellent mileage performance</p>	
 <p>Marked 3PMSF</p>	<p>Good winter properties in both steer and trailer applications</p>	<p><b>Longer mileage</b></p>

Size	PR	Load Index	Speed Rating	Standard Rim	Maximum Load		Maximum Pressure		Tread Depth (mm)	Outer Diameter (mm)	Section width (mm)	TL/TT
					kg	lbs	kPa	psi				
385/65R22.5	20PR	164/-(158/-)	K(L)	11.75	5000	11000	900	131	17.0	1072	389	TL
425/65R22.5	20PR	165/-	K	12.25	5150	11400	830	120	18.0	1124	422	TL
445/65R22.5	20PR	169/-	K	13.00	5800	12800	900	131	18.0	1150	444	TL

TL Tubeless Tire



Truck Series – On/Off Road

# GAM833

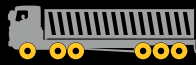

Dumper trailer ,All position



Dumper ,All position





Cement Mixer ,All position



Mixed Service

• **Longer Service Life** • **Excellent Durability & Damage Resistant**

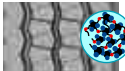
Features	Advantages	Benefits
 <p>CAD pattern design with multi-angle sipes coupled with Equal Force Casing technology</p>	Promotes regular wear pattern with stronger resistance to irregular wear	<b>Extended tire life</b>
 <p>Large casing profile and low heat generation tread package</p>	Promotes cooler running	
 <p>Resilient three longitudinal zig zag groove and continuous shoulder rib with step-shoulder void</p>	Provides good traction in drive position while stronger shoulder rib offers better resistance to side force especially in trailer position	
 <p>Wear resistance tread compound</p>	Delivers long lasting tread wear without compromising cutting and chipping	<b>Longer mileage</b>

Size	PR	Load Index	Speed Rating	Standard Rim	Maximum Load		Maximum Pressure		Tread Depth (mm)	Outer Diameter (mm)	Section width (mm)	TL/TT
					kg	lbs	kPa	psi				
12.00R24	20PR	160/156	K	8.50	4500/4000	9920/8820	850/850	123/123	15.0	1225	315	TT
325/95R24	22PR	162/160	K	9.00	4750/4500	10500/9920	850/850	123/123	17.0	1228	325	TL/TT

TL Tubeless Tire TT Tube Type Tire

## Truck Series – On/Off Road

# GAM837

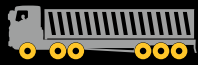

Dumper trailer ,All position



Dumper ,All position







Cement Mixer , All position

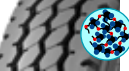

Mixed Service

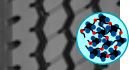
## • Long Service Life • Outstanding Damage Resistance

Features	Advantages	Benefits
 <p>New advanced anti-cut and chip compound</p>	High resistance against tread tearing and cutting from usage on mixed road surface	<b>Extended tire life</b>
 <p>Optimized casing and tread profile</p>	Provides excellent casing protection against external impacts, delivering an optimal footprint for improved wear performance	
 <p>Combined rib and lug pattern design</p>	Delivers excellent traction and braking properties in All position usage	<b>Better traction and braking</b>
 <p>Specially formulated tread compound</p>	Provides resistant to tread wear	<b>Longer mileage</b>
 <p>Solid wide shoulder</p>	Improves protection of the casing and increases stability and driving comfort	<b>Improved stability and driving comfort</b>

Size	PR	Load Index	Speed Rating	Standard Rim	Maximum Load		Maximum Pressure		Tread Depth (mm)	Outer Diameter (mm)	Section width (mm)	TL/TT
					kg	lbs	kPa	psi				
295/80R22.5	18PR	154/149 (152/149)	K(L)	9.00	3750/3250	8270/7160	850/850	123/123	17.5	1044	298	TL
315/70R22.5	18PR	156/150 (154/150)	K(L)	9.00	4000/3350	8820/7390	900/900	131/131	17.5	1014	312	TL

TL Tubeless Tire

Truck Series – On/Off Road

# GAM831

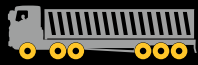

Dumper trailer ,All position



Dumper ,All position







Cement Mixer ,All position



Mixed Service

## • Long Service Life • Outstanding Damage Resistance

Features	Advantages	Benefits	
 Special groove design  New advanced anti-cut and chip compound  Optimized casing and tread profile	<p>Prevents and removes groove stone trapping, protecting the tire from road hazards</p> <p>High resistance against tread tearing and cutting from usage on mixed road surface</p> <p>Provides excellent casing protection against external impacts, delivering an optimal footprint for improved wear performance</p>	<p><b>Extended tire life</b></p>	
 Combined rib and lug pattern design	<p>Delivers excellent traction and braking properties in All position usage</p>		<p><b>Better traction and braking</b></p>
 Solid wide shoulder	<p>Improves protection of the casing and increases stability and driving comfort</p>		<p><b>Improved stability and driving comfort</b></p>

Size	PR	Load Index	Speed Rating	Standard Rim	Maximum Load		Maximum Pressure		Tread Depth (mm)	Outer Diameter (mm)	Section width (mm)	TL/TT
					kg	lbs	kPa	psi				
13R22.5	18PR	156/150 (154/150)	K(L)	9.75	4000/3350	8810/7390	875/875	127/127	18.2	1124	320	TL
315/80R22.5	18PR	158/150 (154/150)	K(L)	9.00	4250/3350	9370/7390	900/900	131/131	18.2	1076	312	TL

TL Tubeless Tire



Truck Series – On/Off Road

# GAM835

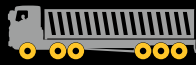

Dumper trailer ,All position



Dumper ,All position





Cement Mixer ,All position

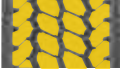
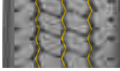

Mixed Service

- **Strong Casing and Extended Service Life**
- **Excellent Cut & Chip Resistant**

Features	Advantages	Benefits
 <p>Optimized read width ratio</p>	Univorm block stiffness,delivers even wear and long mileage	<p><b>Better traction</b></p> <p><b>Delivers longer tire life</b></p>
 <p>Three zigzag grooves with Y-style design</p>	Increased traction with reduced stone retention	
 <p>Shoulder stepped groove design</p>	Improved protection of casing, increased stability and comfort for the driver	
 <p>Deep tread design with cut and Chip resistant compound</p>	Superb resistance to tread tearing, impacts and casing damage in on/off conditions	

Size	PR	Load Index	Speed Rating	Standard Rim	Maximum Load		Maximum Pressure		Tread Depth (mm)	Outer Diameter (mm)	Section width (mm)	TL/TT
					kg	lbs	kPa	psi				
11R22.5	16PR	148/145	K	8.25	3150/2900	6940/6395	850/850	123/123	19.0	1054	279	TL
315/80R22.5	22PR	161/157	J	9.00	4625/4125	10200/9090	900/900	131/131	19.0	1076	312	TL
11R24.5	16PR	149/146	K	8.25	3250/3000	7160/6610	830/830	120/120	19.0	1104	279	TL

TL Tubeless Tire



Truck Series – On/Off Road

# GAM885

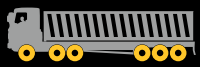

Dumper trailer ,All position



Dumper ,All position







Cement Mixer ,All position

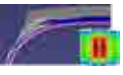

Mixed Service

- **Better wear performance**
- **Enhanced durability**

Features	Advantages	Benefits
 <p>Wider tread with 5% wear volume increase</p>	Delivers enhanced wear performance	<b>Better wear performance</b>
 <p>Optimized crown and belt structure</p>	Optimal footprint for improved wear performance	
 <p>Specialized bead structure and compound</p>	Enhances bead durability to reduce damage	<b>Enhanced durability &amp; extended tire life</b>
 <p>Strong casing and advanced bonding and building process for bead area</p>	Enhances bead strength, reduces bead and sidewall damages in mixed service applications	
 <p>Optimized rib pattern and shoulder design</p>	Improves pattern rigidity to avoid occurrence of irregular wear and shoulder separation	

Size	PR	Load Index	Speed Rating	Standard Rim	Maximum Load		Maximum Pressure		Tread Depth (mm)	Outer Diameter (mm)	Section width (mm)	TL/TT
					kg	lbs	kPa	psi				
11.00R20	18PR	152/149	K	8.00	3550/3250	7830/7160	930/930	135/135	16.0	1085	293	TT
12.00R20	20PR	156/153	K	8.50	4000/3650	8820/8050	900/900	130/130	17.0	1125	315	TT

TT Tube Type Tire

## Truck Series – On/Off Road

# GAM839/GAM839★



Dumper trailer ,All position



Dumper ,All position



Cement Mixer ,All position



Mixed Service

- **Heavy Duty All-Position Tire**
- **Better Damage Resistance & Long Service Life**

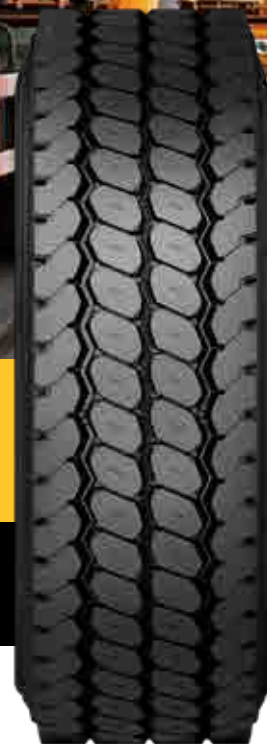

Features	Advantages	Benefits
----------	------------	----------



New proven specially engineered bead design with higher tensile cord and new bonding and building process

Provides stronger, more flexible and resilient bead and sidewall



Strong casing with higher tensile and thicker cord structure

Delivers super strong and tougher tire casing durability



Giti Specially reinforced strong bead structure

Stronger bead for better damage resistance in heavy load operating conditions



Special groove design in the center and V shape on the outer groove

Prevents and removes groove stone trapping, protecting the tire from road hazards



Unique shoulder groove design

Promotes heat dissipation and therefore cooler running, while preventing shoulder separation

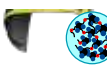

Wear resistance and anti-cut and chip compound

Provides optimal wear life and resistant to damage from cuts

**Extended tire life**



Optimized rib ratio and high pattern block rigidity

Effectively improves pattern rigidity and uniform force distribution on the tread, reducing occurrence of irregular wear

**Delivers longer mileage**

Size	PR	Load Index	Speed Rating	Standard Rim	Maximum Load		Maximum Pressure		Tread Depth (mm)	Outer Diameter (mm)	Section width (mm)	TL/TT
					kg	lbs	kPa	psi				
8.25R20	16PR	139/137	K	6.50	2430/2300	5355/5070	930/930	135/135	14.5	974	236	TT
9.00R20	16PR	144/142	K	7.00	2800/2650	6175/5840	900/900	130/130	15.7	1019	259	TT
10.00R20	18PR	149/146	K	7.50	3250/3000	7160/6610	930/930	135/135	16.2	1054	278	TT
11.00R20	18PR	152/149	K	8.00	3550/3250	7830/7160	930/930	135/135	16.0	1085	293	TT
12.00R20	20PR	156/153	K	8.50	4000/3650	8820/8050	900/900	130/130	16.0	1125	315	TT
11R22.5	16PR	148/145	K	8.25	3150/2900	6940/6395	850/850	123/123	16.2	1054	279	TT
12R22.5	18PR	152/149	L	9.00	3550/3250	7830/7160	930/930	135/135	16.0	1085	300	TT
★ 11.00R20	18PR	152/149	K	8.00	3550/3250	7830/7160	930/930	135/135	16.0	1085	293	TT
★ 12.00R20	20PR	156/153	K	8.50	4000/3650	8820/8050	900/900	130/130	16.0	1125	315	TT

TT Tube Type Tire

★: GAM839 ★



Truck Series – On/Off Road

# GAM871

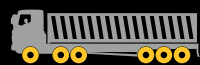

Dumper trailer ,All position



Dumper ,All position





Cement Mixer ,All position



Mixed Service

- **Longer mileage**
- **Strengthened loading capability**

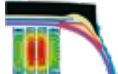
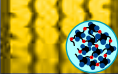

Features	Advantages	Benefits
 Wide tread and deep groove design with 25% wear volume increase  Optimized four belt structure  New cut and chip resistant compound on tread, combined with low heat build up performance	Delivers enhanced wear performance  Even force distribution to ensure good wear performance  Protects tire from cutting, chipping and tearing damages, meanwhile ensure good wear performance	<b>Good wear performance &amp; Extended tire life</b>
 Reinforced bead structure with advanced bonding and building process  Enhanced casing durability by advanced profile technology and inner cord structure	Enhances bead strength to reduce damages from bead separation, bead crack, and bead burst  Improved casing and bead durability to strengthen loading capability and reduce damage	

Size	PR	Load Index	Speed Rating	Standard Rim	Maximum Load		Maximum Pressure		Tread Depth (mm)	Outer Diameter (mm)	Section width (mm)	TL/TT
					kg	lbs	kPa	psi				
12R22.5	20PR	154/151	L	9.00	3750/3450	8270/7610	930/930	135/135	17.6	1085	300	TL
13R22.5	20PR	156/153	L	9.75	4000/3650	8820/8050	930/930	135/135	16.5	1124	320	TL

TL Tubeless Tire

Truck Series – On/Off Road

# GDM686/GDM686+

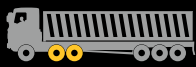

Dumper trailer ,Drive



Dumper ,Drive





Cement Mixer ,Drive

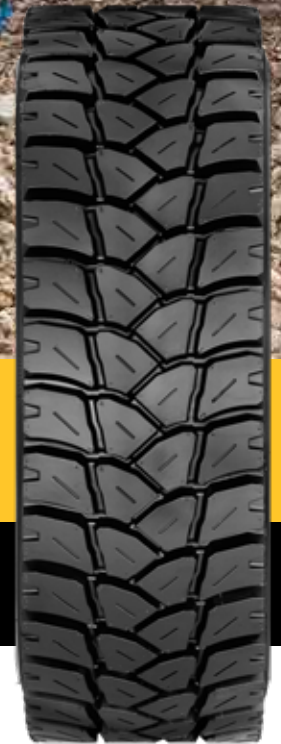

Mixed Service

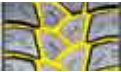

## • Exceptional Traction and Grip • Long Service Life

Features	Advantages	Benefits
 <p>Big block with wide groove design</p>	Delivers better traction and braking properties	<b>Better traction and braking</b>
 <p>Directional extra deep tread design</p>	Provides exceptional grip in rough terrain conditions with excellent self cleaning properties and high resistance to damage	<b>Excellent grip and extended tire life</b>
 <p>Special anti cut and chip compound</p>	Provides excellent protection from tread cuts and chips in aggressive road condition	<b>Extended tire life</b>

Size	PR	Load Index	Speed Rating	Standard Rim	Maximum Load		Maximum Pressure		Tread Depth (mm)	Outer Diameter (mm)	Section width (mm)	TL/TT
					kg	lbs	kPa	psi				
11R22.5	16PR	148/145	J	8.25	3150/2900	6940/6395	850/850	123/123	22.6	1050	279	TL
12R22.5	16PR	152/148	K	9.00	3550/3150	7830/6940	850/850	123/123	23.1	1085	300	TL
295/80R22.5	18PR	152/149	K	9.00	3550/3250	7830/7160	900/900	130/130	22.6	1044	298	TL
315/80R22.5	18PR	156/150	K	9.00	4000/3350	8820/7390	850/850	123/123	23.1	1076	312	TL
315/80R22.5	20PR	158/150	K	9.00	4250/3350	9370/7390	900/900	130/130	23.1	1076	312	TL
★ 13R22.5	18PR	156/150	K	9.75	4000/3350	8820/7390	875/875	127/127	22.1	1124	320	TL

TL Tubeless Tire

★: GDM686+





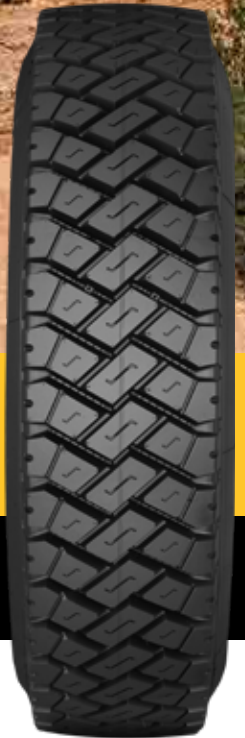

Truck Series – On/Off Road

# GDM676

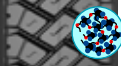

## • Exceptional Traction and Grip • Long Service Life

Features	Advantages	Benefits
 <p>Intertwining tread pattern with deep grooves</p>	Provides excellent traction and braking for safer driving	<b>Better traction and braking</b>
 <p>Sipe design on tread</p>	Strengthens wet grip performance	<b>Safety &amp; Better stability and driving comfort</b>
 <p>Big tread block layout</p>	Resists puncturing and tearing	<b>Extended tire life</b>
 <p>Reinforced casing and bead structure</p>	Improves durability of casing and bead, increasing tire damage resistance from heavy load operating conditions	
 <p>Special anti cut and chip compound</p>	Delivers excellent protection from tread cuts and damage in aggressive road and off-road conditions	

Size	PR	Load Index	Speed Rating	Standard Rim	Maximum Load		Maximum Pressure		Tread Depth (mm)	Outer Diameter (mm)	Section width (mm)	TL/TT
					kg	lbs	kPa	psi				
275/70R22.5	16PR	148/145	K	8.25	3150/2900	6945/6395	900/900	130/130	20.6	958	276	TL

TL Tubeless Tire



Truck Series – On/Off Road

# GDM635

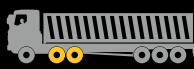

Dumper trailer ,Drive



Dumper ,Drive





Cement Mixer ,Drive

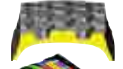

Mixed Service

- **Strong Casing and Extended Service Life**
- **Excellent Traction and Cut & Chip Resistant**

Features	Advantages	Benefits
 <p>Strong independent block design</p>	Block layout optimization provides consistent traction	<b>Better traction</b>
 <p>Ultra wide tread and deep grooves</p>	Long service life in rugged conditions	
 <p>Four steel-belt construction</p>	Exceptional durability and retradability	<b>Delivers longer tire life</b>
 <p>Special cut/chip tread compound</p>	Provides excellent protection from tread cut and chip in aggressive condition	

Size	PR	Load Index	Speed Rating	Standard Rim	Maximum Load		Maximum Pressure		Tread Depth (mm)	Outer Diameter (mm)	Section width (mm)	TL/TT
					kg	lbs	kPa	psi				
11R22.5	16PR	146/143	J	8.25	3000/2725	6610/6005	830/830	120/120	25.5	1065	279	TL
11R24.5	16PR	149/146	J	8.25	3250/3000	7160/6610	830/830	120/120	25.5	1116	279	TL

TL Tubeless Tire



Truck Series – On/Off Road

# GDM616

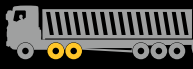

Dumper trailer ,Drive



Dumper ,Drive







Cement Mixer ,Drive



Mixed Service

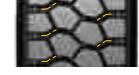

- **Strengthened loading capability**
- **Better damage resistant**
- **Excellent traction**

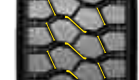
Features	Advantages	Benefits
 <p>Strong casing with high tensile, thick cord and wider belt structure</p>  <p>Reinforced bead structure with advanced bonding and building process</p>  <p>Stone ejector design on the groove bottom</p>  <p>New cut and chip resistant compound on tread, combined with wear performance</p>	<p>Durable casing and tread to protect tire from road hazards</p> <p>Enhances bead strength to reduce damages from bead separation, bead crack, and bead burst</p> <p>Removes groove stone trapping, protecting the tire from road hazards</p> <p>Protects tire from cutting, chipping and tearing damages, meanwhile ensure good wear performance</p>	<p><b>Strengthened loading capability &amp; Extended tire life</b></p>
 <p>Transverse big block design with 30% larger volume on central block</p>  <p>Longitudinal tie bar to connect and optimize the ratio between central block and shoulder block</p>	<p>Improved tread stiffness and traction, reduced deformation under severe road condition</p> <p>Even force distribution on tread to prevent irregular wear</p>	<p><b>Excellent durability and traction</b></p>

Size	PR	Load Index	Speed Rating	Standard Rim	Maximum Load		Maximum Pressure		Tread Depth (mm)	Outer Diameter (mm)	Section width (mm)	TL/TT
					kg	lbs	kPa	psi				
12.00R20	20PR	156/153	J	8.50	4000/3650	8820/8050	900/900	130/130	20.0	1136	315	TT

TT Tube Type Tire





Truck Series – On/Off Road

# GDM680



• **Longer Mileage** • **Heavy Duty** • **Excellent Traction**

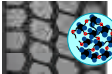

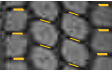
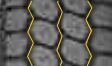
Features	Advantages	Benefits
 <p>Wider tread width design and specially formulated tread compound</p>	Delivers longer mileage	<b>Longer mileage</b>
 <p>Strong casing structure realized by strong and thicker cord</p>	Strong casing strength for increase durability and reliability under continuous load stress	<b>Extended tire life</b>
 <p>Tie-bar design between center blocks</p>	Effectively improve pattern rigidity and thus reducing occurrence of irregular wear	
 <p>Big block with zigzag groove design</p>	Provides excellent traction and braking	<b>Better traction and braking</b>

Size	PR	Load Index	Speed Rating	Standard Rim	Maximum Load		Maximum Pressure		Tread Depth (mm)	Outer Diameter (mm)	Section width (mm)	TL/TT
					kg	lbs	kPa	psi				
9.00R20	16PR	144/142	K	7.00	2800/2650	6175/5840	900/900	130/130	16.8	1019	259	TT
10.00R20	18PR	149/146	K	7.50	3250/3000	7160/6610	930/930	135/135	17.2	1065	278	TT
11.00R20	18PR	152/149	K	8.00	3550/3250	7830/7160	930/930	135/135	18.0	1096	293	TT
12.00R20	20PR	156/153	J	8.50	4000/3650	8820/8050	900/900	130/130	19.0	1136	315	TT
12R22.5	18PR	152/149	L	9.00	3550/3250	7830/7160	930/930	135/135	18.0	1085	300	TL

TL Tubeless Tire TT Tube Type Tire



## Truck Series – On/Off Road

# GDM623

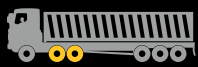

Dumper trailer ,Drive



Dumper ,Drive



Cement Mixer /Drive









Light Dumper ,Drive



Mixed Service

### • Excellent Traction and Grip • Durability & Long Service Life

Features	Advantages	Benefits
 <p>Intertwining tread pattern with deep grooves</p>	Provides excellent traction and braking for safer driving	<b>Better traction and braking</b>
 <p>Sipe design in center pattern blocks</p>	Strengthened wet grip performance	<b>Safety</b>
 <p>Thickened base rubber</p>	Protects groove bottom from tearing and puncturing	<b>Extended tire life</b>
 <p>Reinforced casing and bead structure</p>	Improves durability of casing and bead, increasing tire damage resistance from heavy load operating conditions	
 <p>Special anti cut and chip compound</p>	Delivers excellent protection from tread cuts and damage in aggressive road and off-road conditions	
 <p>Stone ejection design on the groove bottom</p>	Prevents groove from stone trapping and penetration	

Size	PR	Load Index	Speed Rating	Standard Rim	Maximum Load		Maximum Pressure		Tread Depth (mm)	Outer Diameter (mm)	Section width (mm)	TL/TT
					kg	lbs	kPa	psi				
12.00R24	20PR	160/156	K	8.50	4500/4000	9920/8820	850/850	123/123	20.2	1226	313	TT
325/95R24	22PR	162/160	K	9.00	4750/4500	10500/9920	850/850	123/123	20.2	1228	325	TL/TT

TL Tubeless Tire TT Tube Type Tire

Truck Series – On/Off Road

# GDM685



- **Better wear performance & traction**
- **Enhanced durability**

Features	Advantages	Benefits
<p>Bigger central block and tie bar design on shoulder area</p>	Enhanced wear volume and tread rigidity to deliver better wear and traction performance	<p><b>Better wear performance &amp; traction</b></p>
<p>Optimized crown and belt structure</p>	Optimal footprint for improved wear performance	
<p>Specialized bead structure and compound</p>	Enhances bead durability to reduce damage	<p><b>Enhanced durability &amp; extended tire life</b></p>
<p>Strong casing and advanced bonding and building process for bead area</p>	Enhances bead strength, reduces bead and sidewall damages in mixed service applications	
<p>Optimized block pattern and shoulder design</p>	Improves pattern rigidity to avoid occurrence of irregular wear and shoulder separation	

Size	PR	Load Index	Speed Rating	Standard Rim	Maximum Load		Maximum Pressure		Tread Depth (mm)	Outer Diameter (mm)	Section width (mm)	TL/TT
					kg	lbs	kPa	psi				
11.00R20	18PR	152/149	K	8.00	3550/3250	7830/7160	930/930	135/135	17.0	1085	293	TT
12.00R20	20PR	156/153	K	8.50	4000/3650	8820/8050	900/900	130/130	18.0	1125	315	TT

TT Tube Type Tire

## Truck Series – On/Off Road

# GDM625★



- **Heavy Duty All-Position Tire**
- **Stronger Load Capability & Longer Service Life**



Features	Advantages	Benefits
<p>New proven specially engineered bead design with higher tensile cord and new bonding and building process</p>	Provides stronger, more flexible and resilient bead and sidewall	<b>Extended tire life</b>
<p>Strong casing with higher tensile and thicker cord structure</p>	Delivers super strong and tougher tire casing durability	
<p>Giti Specially reinforced strong bead structure</p>	Stronger bead for better damage resistance in heavy load operating conditions	
<p>Wider groove and Anti stone trap bottom groove</p>	Promotes heat dissipation and cooler running, and effectively prevent stone trapping	
<p>Tie bar design</p>	Promotes pattern block rigidity, and prevents chunking and chipping	<b>Better traction</b>
<p>Z shape continuous circumference rib</p>	Promotes traction for the drive tire	

Size	PR	Load Index	Speed Rating	Standard Rim	Maximum Load		Maximum Pressure		Tread Depth (mm)	Outer Diameter (mm)	Section width (mm)	TL/TT
					kg	lbs	kPa	psi				
11.00R20	18PR	152/149	K	8.00	3550/3250	7830/7160	930/930	135/135	18.0	1085	293	TT
12.00R20	20PR	156/153	K	8.50	4000/3650	8820/8050	900/900	130/130	18.0	1125	315	TT

TT Tube Type Tire



Truck Series – On/Off Road

# GDM691



Dumper trailer ,Drive



Dumper ,Drive







Cement Mixer ,Drive



Mixed Service

- Stronger loading capability
- Better damage resistance
- Excellent traction

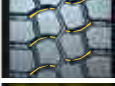

Features	Advantages	Benefits
 <p>Specially reinforced bead structure with advanced bonding and building process</p>	Stronger bead area for better damage resistant in heavy load operating conditions	<p><b>Stronger loading capability &amp; Outstanding damage resistant</b></p>
 <p>Optimized casing profile and four belt structure for better footprint and crown stiffness</p>	Provides stronger load capability and promotes heat dissipation for cooler running, while preventing shoulder separation	
 <p>New advanced anti-cut and chip compound with good wear performance</p>	Resists cuts and chips, while delivering good wear performance in severe mixed service applications	
 <p>Wider tie bar design between blocks</p>	Ensures tread stiffness and prevent irregular wear	<p><b>Extended tire life with superior traction and road adaptability</b></p>
 <p>Newly optimized block design with wider tread to enlarge wear volume effectively</p>	Superior traction and enhanced adaptability to complicated road conditions, like mountainous areas	

Size	PR	Load Index	Speed Rating	Standard Rim	Maximum Load		Maximum Pressure		Tread Depth (mm)	Outer Diameter (mm)	Section width (mm)	TL/TT
					kg	lbs	kPa	psi				
12.00R20	20PR	156/153	J	8.50	4000/3650	8820/8050	900/900	130/130	21.0	1136	315	TT

TT Tube Type Tire





Bus & Coach Series – Intercity & Regional Bus

# GAL817



• Longer Mileage • Better Driving Comfort

Features	Advantages	Benefits
 <p>Wide footprint with wide shoulder design</p>	Designed for usage in both traditional long haul and regional usage conditions	<b>Better Road adaptability</b>
 <p>Redesigned casing construction</p>	Provides an optimized road surface footprint for regular wear and improved mileage	<b>Longer mileage</b>
 <p>Low Noise level</p>	Silent and comfortable drive	<b>Better driving comfort</b>

Size	PR	Load Index	Speed Rating	Standard Rim	Maximum Load		Maximum Pressure		Tread Depth (mm)	Outer Diameter (mm)	Section width (mm)	TL/TT
					kg	lbs	kPa	psi				
255/70R22.5	16PR	140/137	M	7.50	2500/2300	5510/5070	830/830	120/120	14.8	930	255	TL
8R22.5	14PR	130/128	M	6.00	1900/1800	4190/3970	830/830	120/120	12.9	935	203	TL
9R22.5	14PR	136/134	M	6.75	2240/2120	4940/4675	830/830	120/120	13.8	974	229	TL
10R22.5	16PR	144/142	M	7.50	2800/2650	6175/5840	900/900	130/130	14.8	1019	254	TL
7.50R20	14PR	130/128	K	6.00	1900/1800	4190/3970	830/830	120/120	13.0	935	215	TT
8.25R20	14PR	136/134	K	6.50	2240/2120	4940/4675	830/830	120/120	14.0	974	236	TT
9.00R20	16PR	144/142	K	7.00	2800/2650	6175/5840	900/900	130/130	14.5	1019	259	TT

TL Tubeless Tire TT Tube Type Tire







**Bus & Coach Series – Intercity & Regional Bus**

# GAC821

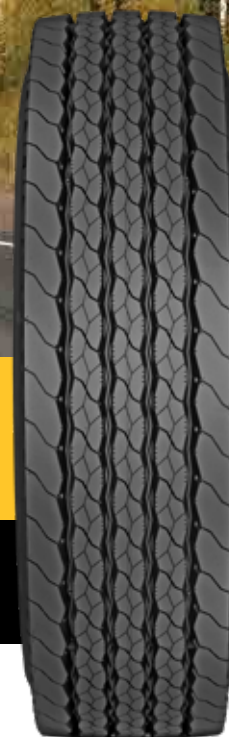

**• Longer Mileage • Better Stability & Handling • Safety**

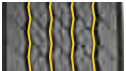

Features	Advantages	Benefits
 <p>Wide pattern design for regional bus operations in all axle positions</p>	Provide excellent stability, handling and braking properties	<b>Excellent stability and handling</b>
 <p>Four main very deep longitudinal tread groves</p>	Provides good wet traction properties and highest mileage	<b>Longer mileage &amp; Better traction and handling</b>
 <p>Casing construction with an optimized footprint in road surface contact</p>	Improves mileage, wear pattern and overall handling	
 <p>Advanced tread block and siping in tread pattern</p>	Reduces noise levels and improves passenger comfort	<b>Better driving comfort</b>
<p><b>M + S</b> M+S marked</p>	Safe usage in winter conditions	<b>Safety</b>

Size	PR	Load Index	Speed Rating	Standard Rim	Maximum Load		Maximum Pressure		Tread Depth (mm)	Outer Diameter (mm)	Section width (mm)	TL/TT
					kg	lbs	kPa	psi				
295/80R22.5	18PR	154/149	L	9.00	3750/3250	8270/7160	850/850	123/123	18.7	1044	298	TL

TL Tubeless Tire







Bus & Coach Series – Intercity & Regional Bus

# GDC629



- **Longer Operating Life • Excellent Traction**
- **Safety & Better Driving Comfort**



Features	Advantages	Benefits
 <p>Optimized pattern design adapted for coach and bus use</p>	Improves the regularity of the wear pattern, reduces noise and increases passenger comfort	<b>Longer operating life &amp; Better driving comfort</b>
 <p>High number of 3D interlocking sipes design with open shoulder</p>	Excellent winter and all season traction	<b>Excellent traction</b>
 <p>Wide pattern design with stabilising rubber elements</p>	Improved stability, handling and provides a very silent ride	<b>Excellent stability and driving comfort</b>
 <p>Achieves 3PMSF performance requirement</p>	Meets legal requirements for 3PMSF certified winter tyres	<b>Safety</b>

Size	PR	Load Index	Speed Rating	Standard Rim	Maximum Load		Maximum Pressure		Tread Depth (mm)	Outer Diameter (mm)	Section width (mm)	TL/TT
					kg	lbs	kPa	psi				
295/80R22.5	16PR	152/148	M	9.00	3550/3150	7830/6940	850/850	123/123	17.2	1044	298	TL

TL Tubeless Tire





## Bus & Coach Series – Long Haul

# GAC812









Coach, All position

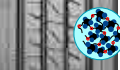

Long Haul

- **Excellent Mileage & Lower Fuel Consumption**
- **Safety & Better in Handling**

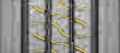

Features	Advantages	Benefits
 <p>Four belt construction</p>	Increases casing and tread stiffness, optimizes contact surface pressure, minimizing tire deformation for longer wear	<b>Delivers longer mileage</b>
 <p>Wider tread width design</p>	Larger tread volume for extended wear life	
 <p>Advanced compound for long haul cool running application</p>	Provides superior wear resistant and low heat generation	<b>Delivers longer mileage and lower fuel consumption</b>
 <p>Optimized rib ratio and high pattern rigidity</p>	Effectively improves pattern rigidity and force distribution, reducing occurrence of irregular wear	
 <p>Four circumferential groove design</p>	Delivers better steering and stability, suited for all position application and long haul service	<b>Safety &amp; Better stability and driving comfort</b>
 <p>Resilient zig-zag center grooves</p>	Provides better controllability and better resistance against road damages	
 <p>Sipe design on tread</p>	Delivers enhanced wet grip of tread	

Size	PR	Load Index	Speed Rating	Standard Rim	Maximum Load		Maximum Pressure		Tread Depth (mm)	Outer Diameter (mm)	Section width (mm)	TL/TT
					kg	lbs	kPa	psi				
295/80R22.5	18PR	152/149	M	9.00	3550/3250	7830/7160	900/900	130/130	14.8	1044	298	TL
11R22.5	18PR	149/146	M	8.25	3250/3000	7160/6610	930/930	135/135	15.0	1054	279	TL

TL Tubeless Tire

## Bus & Coach Series – City Bus & Urban Haulage

# GAU867<sup>V1</sup>



For Bus /All Positions









For haulage operation , All position



Urban



- Longer Mileage • Reinforced Sidewall Protection
- Superior for Electric Bus Use

Features	Advantages	Benefits
 <p>Bigger Overall dimension and contact ratio design</p>	<p>Delivers larger tread volume and longer wear performance</p>	<p><b>Delivers longer mileage</b></p>
 <p>Optimized footprint design to equalize tread pressure distribution</p>	<p>Improves footprint shape, resulting in regular wear and longer tire life</p>	
 <p>Advanced Equal Force Casing technology</p>	<p>Uniforms force distribution enables optimal tire footprint thus result in regular tread wear</p>	
 <p>Wear resistant compound for urban bus/haulage operation, in high frequency of start, stop and turning use</p>	<p>Excellent longer wear performance match to needed operation</p>	
 <p>More resilient Zig-Zag groove design and multiple angle sipes</p>	<p>Provides better traction &amp; grip, and increases tire damage resistance from road hazards</p>	<p><b>Higher Durability &amp; Safety</b></p>
 <p>FEA Optimized casing designed for retreadability</p>	<p>Higher retreadable capabilities</p>	<p><b>Extended Tire Life</b></p>

Size	PR	Load Index	Speed Rating	Standard Rim	Maximum Load		Maximum Pressure		Tread Depth (mm)	Outer Diameter (mm)	Section width (mm)	TL/TT
					kg	lbs	kPa	psi				
225/75R16	12PR	119/116	J	6J	1360/1250	3000/2755	650/650	94/94	13.5	744	223	TL
215/75R17.5	14PR	128/126	M	6.00	1800/1700	3970/3750	750/750	109/109	13.5	767	211	TL
265/70R19.5	18PR	143/141	J	7.50	2725/2575	6005/5675	850/850	123/123	15.5	867	262	TL
255/70R22.5	16PR	140/137	J	7.50	2500/2300	5510/5070	830/830	120/120	17.0	930	255	TL
275/70R22.5	18PR	152/148J (154/148F)	J(F)	8.25	3550/3150	7830/6940	900/900	130/130	18.7	958	276	TL
295/80R22.5	18PR	154/150	J	9.00	3750/3350	8270/7390	900/900	130/130	18.7	1044	298	TL
9R22.5	14PR	136/134	M	6.75	2240/2120	4940/4675	830/830	120/120	17.8	974	229	TL
10R22.5	16PR	144/142	M	7.50	2800/2650	6175/5840	900/900	130/130	17.8	1019	254	TL
11R22.5	16PR	148/145	J	8.25	3150/2900	6940/6395	850/850	123/123	18.7	1050	279	TL

TL Tubeless Tire



## Bus & Coach Series – City Bus & Urban Haulage

# GT867



For city bus , All position







For haulage operation , All position

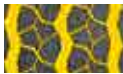

Urban

### • Longer Mileage • High Durability

Features	Advantages	Benefits
 <p>Wear resistant compound for urban bus/haulage operation, in high frequency of start, stop and turning use</p>	<p>Excellent longer wear performance match to needed operation</p>	<p><b>Delivers longer mileage</b></p>
 <p>Advanced Equal Force Casing technology</p>	<p>Uniform force distribution enables optimal tire footprint at various loads level thus result in regular tread wear</p>	
 <p>Zig-Zag groove and multiple angle sipes</p>	<p>Provides excellent traction &amp; prevents skidding on wet roads</p>	<p><b>Safety</b></p>
 <p>Sidewall protector rib</p>	<p>Protects casing and sidewall from road hazard and curbing damage</p>	<p><b>Extended tire life</b></p>
 <p>Tire casing designed for retreadability</p>	<p>Higher retreadable capabilities</p>	

Size	PR	Load Index	Speed Rating	Standard Rim	Maximum Load		Maximum Pressure		Tread Depth (mm)	Outer Diameter (mm)	Section width (mm)	TL/TT
					kg	lbs	kPa	psi				
245/70R19.5	16PR	136/134	M	7.50	2240/2120	4940/4675	825/825	120/120	15.8	839	248	TL
245/70R19.5	18PR	141/140	M	7.50	2575/2500	5675/5510	860/860	125/125	15.8	839	248	TL
305/70R22.5	16PR	152/150 (154/150)	J(E)	9.00	3550/3350	7830/7390	860/860	125/125	19.0	1000	305	TL
315/80R22.5	18PR	158/150	J	9.00	4250/3350	9370/7390	900/900	131/131	18.7	1076	312	TL
275/70R22.5	16PR	150/145 (154/148)	J(E)	8.25	3350/2900	7390/6395	900/900	130/130	18.7	958	276	TL
275/70R22.5	18PR	152/148	J	8.25	3550/3150	7830/6940	900/900	130/130	18.7	958	276	TL
10R22.5	16PR	144/142	J	7.50	2800/2650	6175/5840	900/900	130/130	15.8	1019	254	TL
12R22.5	18PR	152/149	J	9.00	3550/3250	7830/7160	930/930	135/135	18.7	1085	300	TL

TL Tubeless Tire



Light Truck Series – Regular Transport

# GSR235







Commercial Light Truck, All position



Regional

• Durable Casing • Excellent Wear Performance • Safety

Features	Advantages	Benefits
 <p>All steel belt structure design</p>	Delivers strong and tough tire casing durability	<p><b>Deliver higher durability &amp; longer mileage</b></p>
 <p>Special wear resistant compound</p>	Promotes long wear-resistant performance	
 <p>Diamond-shape stone ejector design in groove bottom</p>	Effectively improves pattern rigidity and resistance to groove damages	
 <p>Optimized rib ratio and pattern design</p>	Delivers regular wear, reducing occurrence of irregular wear	
 <p>Four circumferential main groove with multi width sipe on tread</p>	Provides exceptional water evacuation and wet grip performance in rough terrain conditions	<p><b>Safety</b></p>

Size	PR	Load Index	Speed Rating	Standard Rim	Maximum Load		Maximum Pressure		Tread Depth (mm)	Outer Diameter (mm)	Section width (mm)	TL/TT
					kg	lbs	kPa	psi				
195/85R16	12PR	114/112	L	5½J	1180/1120	2600/2470	600/600	87/87	8.5	738	196	TL
205/85R16	12PR	117/115	L	5½J	1285/1215	2835/2680	600/600	87/87	8.5	754	203	TL

TL Tubeless Tire



Light Truck Series – Regular Transport

# GSR236







Commercial Light Truck, All position

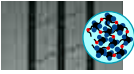

Regional

- **Excellent Mileage Performance**
- **Superior Handling and Driving Comfort**

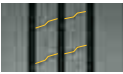

Features	Advantages	Benefits
 High mileage tread compound with focus on regional and urban application  3 groove tread design with diamond-shaped groove wall	<p>Deliver longer mileage in Combi road usage condition</p> <p>To enhance pattern stiffness and extend the mileage range</p>	<p><b>Excellent mileage performance</b></p>
 Deep transversal sipes on tread to improve grip and traction in wet condition	<p>High level of safety and driving stability in every kind of usage conditions</p>	<p><b>Safety</b></p>
 Robust construction with extremely wide shoulder ribs design	<p>To prevent irregular wear and improve cornering stability, at the same time, excellent protection to shoulder wear phenomena</p>	<p><b>Longer operation life</b></p>

Size	PR	Load Index	Speed Rating	Standard Rim	Maximum Load		Maximum Pressure		Tread Depth (mm)	Outer Diameter (mm)	Section width (mm)	TL/TT
					kg	lbs	kPa	psi				
215/75R17.5	14PR	128/126	M	6.00	1800/1700	3970/3750	750/750	109/109	13.0	767	211	TL

TL Tubeless Tire



## Light Truck Series – Regular Transport

# GAL816+



- **Excellent Mileage** • **Outstanding Wear-Resistance**
- **Better Handling**

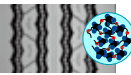
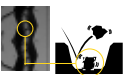

Features	Advantages	Benefits
 <p>Wide five-rib tread with Equal Force Casing technology</p>	Uniform force distribution enables optimal tire footprint and regular wear	<b>Delivers longer mileage</b>
 <p>Special wear-resistant compound</p>	Promotes long wear-resistant performance	
 <p>Stone ejectors</p>	Better road hazard protection from stone drilling at groove bottom	<b>Extended tire life</b>
 <p>Solid shoulder rib</p>	For better cornering and handling	<b>Better handling</b>

Size	PR	Load Index	Speed Rating	Standard Rim	Maximum Load		Maximum Pressure		Tread Depth (mm)	Outer Diameter (mm)	Section width (mm)	TL/TT
					kg	lbs	kPa	psi				
7.00R16	14PR	118/114	M	5.50F	1320/1180	2910/2600	770/770	110/110	11.0	775	200	TL/TT
7.50R16	14PR	122/118	M	6.00G	1500/1320	3305/2910	770/770	110/110	12.0	805	215	TL/TT
8.25R16	16PR	128/124	M	6.50H	1800/1600	3970/3530	770/770	110/110	12.5	855	235	TT

TL Tubeless Tire TT Tube Type Tire

Light Truck Series – Regular Transport  
Truck Series – Highway & Regional

# GAR850







Commercial Light Truck, All position

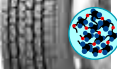

Regional

- **Longer Mileage** • **Excellent Traction**
- **Durable Casing** • **Wet Grip Performance**

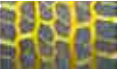

Features	Advantages	Benefits
 <p>Giti specially formulated tread compound</p>	Improved wear resistance of tread	<b>Delivers longer mileage</b>
 <p>Advanced Equal Force Casing technology</p>	Uniform force distribution enables optimal tire footprint at various loads level thus result in regular tread wear	
 <p>Inter-dependant pattern block in center and continuous pattern block on shoulder</p>	Restrict excessive block movement, effectively reducing abnormal wear	
 <p>Multiple edge concept pattern block and sipe design</p>	Delivers excellent traction and wet grip performance	<b>Better traction, braking and safety</b>
 <p>Retread Tire casing designed for retreadability</p>	Higher retreadable capabilities	<b>Extended tire life</b>

Size	PR	Load Index	Speed Rating	Standard Rim	Maximum Load		Maximum Pressure		Tread Depth (mm)	Outer Diameter (mm)	Section width (mm)	TL/TT
					kg	lbs	kPa	psi				
225/80R17.5	14PR	123/122	L	6.75	1550/1500	3415/3305	700/700	102/102	13.5	805	226	TL
245/70R19.5	16PR	136/134	J	7.50	2240/2120	4940/4675	850/850	123/123	14.0	839	248	TL
295/80R22.5	18PR	153/150	J	9.00	3650/3350	8050/7390	900/900	130/130	15.5	1044	298	TL
11R22.5	16PR	148/145	L	8.25	3150/2900	6940/6395	800/800	116/116	14.7	1052	279	TL

TL Tubeless Tire

Light Truck Series – Regular Transport  
Light Bus Series – Light Bus

# GAR820



Commercial Light Truck, All position







Light Bus, All position



Regional

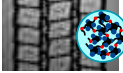

- **Excellent Mileage • Outstanding Wear-Resistance**
- **Superior Handling and Driving • Comfort**

Features	Advantages	Benefits
 <p>New pattern design with wide solid shoulders</p>	Provides outstanding resistance to irregular wear on shoulder area, while improve handling and driving comfort performance	<b>Improved stability and driving comfort</b>
 <p>Optimized casing and footprint design</p>	Allows for regular wear throughout tire life, delivering excellent mileage performance	<b>Delivers longer mileage</b>
 <p>Specialized tread compound</p>	Delivers resistance to tread wear and tear thereby resulting in excellent mileage & longer life	
 <p>Center block pattern design</p>	Increases traction and braking capabilities in all-position usage	<b>Better traction and braking</b>
 <p>New Improved bead construction</p>	Facilitates mounting of tire to rim, improving overall uniformity of tire	<b>Easier mounting</b>

Size	PR	Load Index	Speed Rating	Standard Rim	Maximum Load		Maximum Pressure		Tread Depth (mm)	Outer Diameter (mm)	Section width (mm)	TL/TT
					kg	lbs	kPa	psi				
225/75R17.5	14PR	129/127	M	6.75	1850/1750	4080/3860	725/725	105/105	13.0	783	226	TL
245/70R17.5	14PR	136/134	M	7.50	2240/2120	4940/4675	850/850	123/123	13.5	789	248	TL
9.5R17.5	16PR	143/141	K	6.75	2725/2575	6005/5675	875/875	127/127	12.5	842	240	TL
235/75R17.5	16PR	132/129	J	6.75	2000/1850	4410/4079	830/830	120/120	13.5	797	233	TL
205/75R17.5	14PR	124/122	M	6.00	1600/1500	3530/3305	750/750	110/110	12.5	753	204	TL
215/75R17.5	14PR	128/126	M	6.00	1800/1700	3970/3750	750/750	110/110	13.0	767	211	TL
235/75R17.5	14PR	132/130	M	6.75	2000/1900	4410/4190	760/760	110/110	13.5	797	233	TL

TL Tubeless Tire





## Light Truck Series – Regular Transport

# GAR711



Commercial Light Truck, All position





Light Truck, All position



Regional

- **Good loading capability**
- **Longer Mileage**
- **Lower Fuel Consumption**

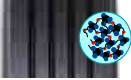

Features	Advantages	Benefits
 <p>Four groove design</p>	Provides better steering and stability and excellent water evacuation	<p><b>Longer mileage and fuel consumption</b></p>
 <p>Dedicated compound formula for mixed long distance and regional usage</p>	Reduce fuel consumption while providing high mileage	
 <p>New generation pattern featuring new groove design and extra wide shoulder</p>	Provides good protection in shoulder area and very regular wear	<p><b>Good loading capability and longer operating life</b></p>
 <p>Advanced Equal Force Casing technology</p>	Uniform force distribution enables optimal tire footprint at various loads level thus result in regular tread wear	

Size	PR	Load Index (143/141 144/144)	Speed Rating L (F)	Standard Rim 6.75	Maximum Load		Maximum Pressure		Tread Depth (mm) 13.5	Outer Diameter (mm) 797	Section width (mm) 233	TL/TT TL
					kg 2725/2575	lbs 6005/5675	kPa 860/860	psi 125/125				
235/75R17.5	16PR	143/141 (144/144)	L (F)	6.75	2725/2575	6005/5675	860/860	125/125	13.5	797	233	TL

TL Tubeless Tire







Light Truck Series – Regular Transport

# GAR828S



• **Longer Mileage** • **Excellent Durability and Damage Resistant**

Features	Advantages	Benefits
 <p>Four zigzag groove design</p>	Provide an excellent resistance to wet-sliding and irregular wear	<p><b>Delivers longer mileage</b></p>
 <p>Variable pitch design</p>	Reduce rolling noise greatly	
 <p>Optimization of bead construction</p>	Show the outstanding performance of endurance	<p><b>Extended tire life Better handling</b></p>
 <p>Specific tread compound</p>	Better resistance to abrasion	
 <p>Professional design of groove and usage of anti-tearing compound</p>	Avoid of groove cracks effectively	

Size	PR	Load Index	Speed Rating	Standard Rim	Maximum Load		Maximum Pressure		Tread Depth (mm)	Outer Diameter (mm)	Section width (mm)	TL/TT
					kg	lbs	kPa	psi				
8.25R16	18PR	131/129	L	6.50H	1950/1850	4300/4080	850/850	123/123	12.0	855	235	TT

TT Tube Type Tire







Light Truck Series – Regular Transport

# GAR859/GAR859+



- Long Operating Life • Durable & Damage Resistant
- Irregular Wear Resistant



Features	Advantages	Benefits
 <p>Special wear resistant compound</p>  <p>Optimal rib ratio and tread pattern rigidity</p>	<p>Promotes excellent wear resistant performance</p> <p>Equalizes distribution of tire contact surface pressure, preventing tire from irregular wear</p>	<p><b>Delivers longer mileage</b></p>
 <p>Enhanced bead filler design</p>  <p>Enhanced shoulder design and zig-zag longitudinal groove</p>	<p>Minimizes flexing, movement, and damage of bead area, improving tire load capability</p> <p>Provides effective heat dissipation and better damage resistance in various road conditions</p>	
 <p>Unique large groove wall design</p>	<p>Effectively prevents groove and casing from stone penetration</p>	

Size	PR	Load Index	Speed Rating	Standard Rim	Maximum Load		Maximum Pressure		Tread Depth (mm)	Outer Diameter (mm)	Section width (mm)	TL/TT
					kg	lbs	kPa	psi				
6.50R16	12PR	110/105	L	5.50F	1060/925	2335/2040	670/670	97/97	11.0	750	185	TT
8.25R16	16PR	128/124	M	6.50H	1800/1600	3970/3530	770/770	110/110	14.5	855	235	TT
★ 7.00R16	14PR	118/114	L	5.50F	1320/1180	2910/2600	770/770	110/110	11.0	775	200	TL/TT
★ 7.50R16	14PR	122/118	L	6.00G	1500/1320	3305/2910	770/770	110/110	14.5	805	215	TT

TL Tubeless Tire TT Tube Type Tire

★: GAR859+



## Light Truck Series – Regular Transport

# GDR638







Commercial Light Truck, Drive position



Regional

- **Excellent Mileage and Traction** • **Outstanding Wear-Resistance**
- **Superior Stability and Driving** • **Comfort**



Features	Advantages	Benefits
 <p>Solid pattern design and block stiffness</p>	Provides good traction and braking with improved vehicle stability and driver comfort	<b>Delivers longer mileage</b>
 <p>Optimized casing and footprint design</p>	Allows for regular wear throughout tire life, delivering excellent mileage performance	<b>Delivers longer mileage</b>
 <p>Specialized tread compound</p>	Delivers resistance to tread wear and tear, thereby resulting in excellent mileage and longer life	
 <p>New Improved bead construction</p>	Improves uniformity and facilitates easier fitting to the rim	<b>Easier mounting</b>

Size	PR	Load Index	Speed Rating	Standard Rim	Maximum Load		Maximum Pressure		Tread Depth (mm)	Outer Diameter (mm)	Section width (mm)	TL/TT
					kg	lbs	kPa	psi				
235/75R17.5	16PR	132/130	M	6.75	2000/1900	4410/4190	830/830	120/120	15.0	797	233	TL
225/70R19.5	14PR	128/126	L	6.75	1800/1700	3970/3750	760/760	110/110	14.3	817	226	TL
265/70R19.5	16PR	140/138	M	7.50	2500/2360	5510/5205	790/790	115/115	16.5	867	262	TL
225/75R17.5	14PR	129/127	M	6.75	1850/1750	4080/3860	725/725	105/105	15.0	783	226	TL
285/70R19.5	16PR	146/145	M	8.25	3000/2900	6610/6395	900/900	130/130	17.0	895	283	TL
245/70R19.5	16PR	136/134	M	7.50	2240/2120	4940/4675	830/830	120/120	16.0	839	248	TL
245/70R17.5	14PR	136/134	M	7.50	2240/2120	4940/4675	850/850	123/123	14.5	789	248	TL
205/75R17.5	14PR	124/122	M	6.00	1600/1500	3530/3305	750/750	110/110	14.0	753	204	TL
215/75R17.5	14PR	126/124	M	6.00	1700/1600	3750/3530	724/724	105/105	14.5	767	211	TL
9.5R17.5	18PR	143/141	K	6.75	2725/2575	6005/5675	875/875	127/127	12.5	842	240	TL







TL Tubeless Tire

## Light Truck Series – Dumper

# GDM623

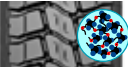

### • Excellent Traction and Grip • Durability & Long Service Life

Features	Advantages	Benefits
 <p>Intertwining tread pattern with deep grooves</p>	Provides excellent traction and braking for safer driving	<b>Better traction and braking</b>
 <p>Sipe design in center pattern blocks</p>	Strengthened wet grip performance	<b>Safety</b>
 <p>Thickened base rubber</p>	Protects groove bottom from tearing and puncturing	<b>Extended tire life</b>
 <p>Reinforced casing and bead structure</p>	Improves durability of casing and bead, increasing tire damage resistance from heavy load operating conditions	
 <p>Special anti cut and chip compound</p>	Delivers excellent protection from tread cuts and damage in aggressive road and off-road conditions	
 <p>Stone ejection design on the groove bottom</p>	Prevents groove from stone trapping and penetration	

Size	PR	Load Index	Speed Rating	Standard Rim	Maximum Load		Maximum Pressure		Tread Depth (mm)	Outer Diameter (mm)	Section width (mm)	TL/TT
					kg	lbs	kPa	psi				
7.00R16	14PR	118/114	K	5.50F	1320/1180	2910/2600	770/770	110/110	14.5	785	200	TT
8.25R16	16PR	128/124	K	6.50H	1800/1600	3970/3530	770/770	110/110	15.0	855	235	TT
7.50R16	16PR	122/118	K	6.00G	1500/1320	3305/2910	770/770	110/110	15.0	805	215	TT





TT Tube Type Tire

# TRUCK AND BUS TIRE OEM PARTNERS











## ANHUI KAILE

	Size	Pattern
TRAILER 	12R22.5	PAL525
TRAILER 	11.00R20	PW01
TRAILER 	12.00R20	PW01
TRAILER 	12R22.5	PAL525
DUMPER 	12.00R20	PW01

## BEIBEN

	Size	Pattern
V3ET 	12R22.5	PAL525
V3MT 	12R22.5	PAL525
V3 DUMPER 	12.00R20	PW01
V3 DUMPER 	12.00R20	PW01 PDM319

## CDW

	Size	Pattern
HEAVY DUTY TRUCK TRACTOR 012 	11.00R20	PW01
HEAVY DUTY TRUCK DUMPER 012 	8.25R16	PW01





## DONGFENG

	Size	Pattern
DFL3310B2 	12.00R20	PW01



## DONGFENG

	Size	Pattern
TIAN LONG KL 	12R22.5 18PR	PAL525
	12R22.5 18PR	PAL526
	295/80R22.5 18PR	PAL520
TIAN LONG KL 	12R22.5 18PR	PAL525
	11.00R20 18PR	PW02
	11.00R20 18PR	PW602
TIAN LONG KC 	11.00R20 18PR	PW01
	12.00R20 18PR	PW01
TIAN JING KR 	9.00R20 16PR	GAR827
	10R22.5 16PR	GAR558











## DFLZ

	Size	Pattern
CHENGLONG H5 TRACTOR 	12R22.5	PAL525
CHENGLONG M3 	275/80R22.5	PAL525
CHENGLONG M3 LOADER 	10.00R20	PW02
CHENGLONG T5 SPECIALTY 	315/60R22.5	GSR225
H7 DUMPER 	12.00R20 18PR	PW01
	12.00R20 16PR	PW01





## FOTON AUMARK

	Size	Pattern
AUMARK S1, S3 	700R16	PAL528
	750R16	PAL528
AUMARK S5 	11R22.5	PAL525
AUMARK R 	10R22.5	PAL517
	11R22.5	PAL525
	275/80R22.5	PAL525

## FOTONDAIMLER

	Size	Pattern
EST-A TRUCKTRACTOR 6x4 	295/80R22.5	PAL520
EST-A 	12R22.5	PAL526 PW622A
EST TRUCKTRACTOR 6x4 	12R22.5	PAL526
GTL2018 TRUCKTRACTOR 6x4 	12R22.5	PAL526
ETX TRUCKTRACTOR 6x4 	12R22.5	PAL526
ETX LOADER 8X4 	12R22.5	PAL526
GTL2018 LOADER 8X4 	12R22.5	PAL526
GTL DUMPER 6X4 	12.00R20	PW01
ETX SPECIAL VEHICLE 8X4 	315/60R22.5	GSR225
OU MAN LNG 	12R22.5	PAL526

## FOTON OLLIN

	Size	Pattern
OLLIN CTS 	750R16	PAL528
OLLIN CTX 	700R16	PAL528
OLLIN CNG 	8.25R16	PW01
OLLIN TRANSPORT 	700R16	PAL528
OLLIN Medium Truck 	11R22.5	PAL525



**FOTON OLLIN**



	Size	Pattern
OLLIN PALACE 	11R22.5	<b>GAL836+</b>

**FOTON FORLAND**



	Size	Pattern
MEDIUM TRUCK 	275/80R22.5 18PR	<b>PAL525</b>

**CAMC**





	Size	Pattern
CEMENT MIXER 	11.00R20 12.00R20	<b>PW01</b>

HANMA H9 TRACTOR 	12R22.5	<b>PAL525</b>
---	---------	---------------

HANMA H6 TRACTOR 	12R22.5	<b>PAL525</b>
	11.00R20	<b>PW01</b>
	12R22.5	<b>PW622A</b>

XINGKAIMA TRACTOR 6x4 	12.00R20 11.00R20	<b>PW01</b>
	12R22.5	<b>PAL525</b>

XINGKAIMA DUMPER 6x4 	12.00R20 11.00R20	<b>PW01</b>
---	----------------------	-------------

XINGMA SPECIL VEHICLE 	385/65R22.5	<b>GTL919</b>
--	-------------	---------------

**HYUNDAI**



	Size	Pattern
ZHIDAO 300M 	750R16LT	<b>PAL528</b>

QTC LIGHT TRUCK 	700R16	<b>PAL528</b>
	750R16	<b>PAL528</b>

CHUANGHU TRAC-TOR 	295/80R22.5	<b>PAL520</b>
--	-------------	---------------

HONG TU 	750R16 700R16	<b>PAL528</b>
--	------------------	---------------

HONG TU EV 	650R16	<b>SUPER TRAVELER 668V1</b>
---	--------	-----------------------------

**HINO**



	Size	Pattern
Dutro 110 	750 - 15 12PR	<b>SU88N</b>

Dutro 130 	750 - 16 14PR	<b>SU88N</b>
--	---------------	--------------

FG/FC Series 	10.00 - 20 16PR	<b>Miller RFD</b>
---	-----------------	-------------------

FM/FL Series 	11.00 - 20 16PR	<b>Miller RFD</b>
---	-----------------	-------------------

FM/FL Series 	11.00 R20	<b>GA0822</b>
---	-----------	---------------

**ISUZU**





	Size	Pattern
Isuzu NLR Series 	750 - 15 12PR	<b>SU88N</b>

Isuzu NMR Series 	750 - 16 14PR	<b>SU88N</b>
---	---------------	--------------

Isuzu FTR 	9.00 - 20 14PR	<b>Miller RFD</b>
--	----------------	-------------------

Isuzu F Series 4x2 	10.00 - 20 16PR	<b>Miller RFD</b>
---	-----------------	-------------------

Isuzu F Series 6x2 	11.00 - 20 16PR	<b>Miller RFD</b>
---	-----------------	-------------------

Isuzu F Series 6x4 	11.00 - 20 16PR	<b>Super Grip</b>
---	-----------------	-------------------

**MERCEDES BENZ**



	Size	Pattern
Axor 2528C 	11.00 - 20 16PR	<b>Miller RFD</b>
	11.00 - 20 16PR	<b>Lug</b>

Axor 40 & 49TT 	11.00 R20	<b>GAZ892</b>
---	-----------	---------------

**JAC**



	Size	Pattern
GALLOP CARGO TRUCK 	8.25R20 9.00R20 10.00R20	<b>PW01</b>
	9R22.5	<b>PAL517</b>

GALLOP TRACTOR 	11.00R20 11R22.5 12.00R20	<b>PW01</b>
	12R22.5	<b>PAL525</b>

GALLOP VEHICLE 	10.00R20 11.00R20 12.00R20	<b>PW01</b>
---	----------------------------------	-------------

GALLOP SPECIAL VEHICLE 	11.00R20 12.00R20	<b>PW01</b>
---	----------------------	-------------

VISDA 	9.00R20	<b>PW02</b>
--	---------	-------------

JUN LING V5 	750R16LT	<b>PAL528</b>
---	----------	---------------

SHUAI LING Q6 	750R16LT	<b>PAL528</b>
--	----------	---------------

SHUAI LING Q7 	750R16	<b>PAL528</b>
--	--------	---------------

JUN LING E6 	750R16	<b>PAL528</b>
--	--------	---------------

JUN LING E3 	6.50R16 LT	<b>SUPER TRAVELER 668</b>
--	------------	---------------------------

GEERFA A5 	12R22.5	<b>PAL525</b>
--	---------	---------------

GEERFA A5 CARGO 	10.00R20	<b>PW02</b>
	11R22.5	<b>GAC812</b>

COMMERCIAL A SERIES 	700R16	<b>SUPER TRAVELER 668</b>
	215/75R175	<b>GAR820</b>





CITY SERIES 	750R16 LT	<b>SUPER TRAVELER 668</b>
--	-----------	---------------------------





**MITSUBISHI MOTORS**



	Size	Pattern
Colt FE 71 	750 - 15 12PR	<b>SU88N</b>
Colt FE 73 Series 	700 - 16 14PR	<b>SU88N</b>
Colt FE 74 Series 	750 - 16 14PR	<b>SU88N</b>
Fuso FM/FN Series 	10.00 - 20 16PR	<b>Miller RFD</b>
	11.00 - 20 16PR	<b>Miller RFD</b>

**YUEJIN**



	Size	Pattern
C500 	750R16LT	<b>PAL528</b>
C300 	700R16LT	<b>PAL528</b>
RUIYU DUMPER 4x2 	8.25R16	<b>PW01</b>



**TOYOTA**



	Size	Pattern
Dyna 	750 - 16 14PR	<b>SUPER 88N</b>



**WAW**



	Size	Pattern
LIGHT VAN 	195/70R15	<b>MAXWAY</b>
MEDIUM TRUCK 	10R22.5	<b>PAL517</b>
	11R22.5	<b>PAL525</b>
	10.00R20	<b>PW02</b>

**UD TRUCKS**



	Size	Pattern
Quester Series 	11.00 - 20 16PR	<b>MILER (RFD)</b>
	11.00 R20	<b>GAZ892</b>
	11.00 R20	<b>GA0822</b>
Croner Series 	235/75 R175	<b>GAR820</b>
	295/80 R225	<b>GAR879</b>
	11R22.5	<b>GAR879</b>

LIGHT TRUCK

	700R16 750R16	<b>PAL528</b>
W5 	700R16	<b>PAL528</b>

**CNHTC**



	Size	Pattern
HOWO LTR 	750R16	<b>PAL528</b>

**ANKAI** 

	Size	Pattern
HFF6122WK79 	295/80R22.5	<b>GAL817</b>
HFF6850K10EV 	10R22.5	<b>GAL817</b>
HFF6110K09 	11R22.5	<b>GAL817</b>
HFF6810 	9R22.5	<b>GAL817</b>
HFF6122WK79 	295/80R22.5	<b>GAL817</b>
HFF6870G05D 	9R22.5	<b>GAL817</b>
HFF6901KZ 	10R22.5	<b>GAL817</b>
HFF6935K58 	10R22.5	<b>GAL817</b>
HFF6121G15C 	275/70R22.5	<b>GAU867V1</b>

**BYD** 

	Size	Pattern
K8 	275/70R22.5	<b>GAU867V1</b>
C8 	275/70R22.5	<b>GAL817</b>
K7 	255/70R22.5	<b>GAL817</b>
C7 	245/70R19.5	<b>GSR 225</b>
C9 	295/80R22.5	<b>GAL817</b>
K9 	295/80R22.5	<b>GT867</b>





**BYD** 

	Size	Pattern
C6 	215/75R175	<b>GAR820</b>







**KINGLONG** 

	Size	Pattern
XMQ6135QY 	295/80R22.5	<b>GAL817</b>
XMQ6871CY 	10R22.5	<b>GAL817</b>
XMQ6901AY 	275/80R22.5	<b>GSR235</b>
XMQ6129 	295/80R22.5	<b>GAL817</b>
XMQ6125 	295/80R22.5	<b>GAU867V1</b>
XMQ6107 	275/70R22.5	<b>GAU867V1</b>

**HIGER** 

	Size	Pattern
KLQ6812 	9R22.5	<b>GAL817</b>
KLQ6978 	10R22.5	<b>GAL817</b>
KLQ6128G 	11R22.5	<b>GT867</b>
A80/KLQ6127Q 	295/80R22.5	<b>GAL817</b>
KLQ6109 	11R22.5	<b>GAL817</b>
KLQ6125KA 	315/80R22.5	<b>GAL836</b>

**HIGER** 

	Size	Pattern
KLQ6850GEVX 	255/70R22.5	<b>GAL817</b>
KLQ6832 	245/70R19.5	<b>GSR225</b>
KLQ6118 	275/70R22.5	<b>GT867</b>
KLQ6108G 	11R22.5	<b>GT867</b>
KLQ6966 	10R22.5	<b>GT279</b>
KLQ6850GAE5 	255/70R22.5	<b>GAU867V1</b>
KLQ6129 	295/80R22.5	<b>GAL817</b>

**YAXING** 



	Size	Pattern
JS6850H 	9R22.5	<b>GAL817</b>
YBL6796H 	750R20	<b>GAL817</b>
YBL6123H 	295/80R22.5	<b>GAL817</b>
YBL6990TA 	10R22.5	<b>GAL817</b>
JS6752T 	255/70R22.5	<b>GAL817</b>
JS6111SH 	275/70R22.5	<b>GAU867V1</b>



**YUTONG**

	Size	Pattern
CL6/7 	215/75R175	<b>GAR820E</b>
E8 	245/70R19.5	<b>GSR225</b>
E10 	11R22.5	<b>GT867</b>
E12 	295/80R22.5	<b>GT867</b>
T7 	215/75R175	<b>GAR820E</b>
ZK6808HQ5Z 	255/70R22.5	<b>GAL817</b>
ZK6108HG 	275/70R22.5	<b>GT867</b>
ZK6120R41 	295/80R22.5	<b>GAL817</b>
ZK6120GEV 	305/70R22.5	<b>GT867</b>
ZK6908H 	9R22.5	<b>GAL817</b>
ZK6100系列 	275/80R22.5	<b>GSR235</b>
ZK6938HN 	10R22.5	<b>GAL817</b>









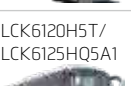

**YUTONG**

	Size	Pattern
HI2 HYBRID 	455/45R22.5	<b>GDU656</b>
ZK6815 ELETRIC BUS 	265/70R19.5	<b>GSR225</b>
ZK6107HN 	11R22.5	<b>GAL817</b>

**SUNLONG**

	Size	Pattern
SLK6819 	245/70R19.5	<b>GT867</b>
SLK6119G 	11R22.5	<b>GT867</b>
SLK6730 	8R22.5	<b>GAL817</b>
SLK6122 	12R22.5	<b>GAL817</b>
SLK6126 	295/80R22.5	<b>GAL817</b>
SLK6891 	9R22.5	<b>GT867</b>
SLK6106 	10R22.5	<b>GAL817</b>
SLK6109 	275/70R22.5	<b>GAU867V1</b>
SLK6118 	11R22.5	<b>GAL817</b>

**ZHONGTONG**

	Size	Pattern
LCK6775RA 	8R22.5	<b>GAL817</b>
LCK6875RA/ LCK6118EV1 	10R22.5	<b>GT279</b>
LCK6906H5A1 	10R22.5	<b>GAL817</b>
LCK6120H5T/ LCK6125HQ5A1 	11R22.5	<b>GAL817</b>
LCK6117EVGA1 	11R22.5	<b>GT867</b>
LCK6720D51 	215/75R175	<b>GT879</b>
LCK6780H5Q 	225/70R19.5	<b>GT279</b>
LCK6809EVG3A7 	245/70R19.5	<b>GSR225</b>
LCK6808EVQGA1 	255/70R22.5	<b>GAL817</b>
LCK6108EVG3A6 	275/70R22.5	<b>GT867</b>
LCK6128HQIL/ LCK6123RA 	295/80R22.5	<b>GAL817</b>
LCK6826EVGA1 	265/70R19.5	<b>GSR225</b>

# **Section 5**

## **Tire Basics**

# Designations, Load and Speed Index

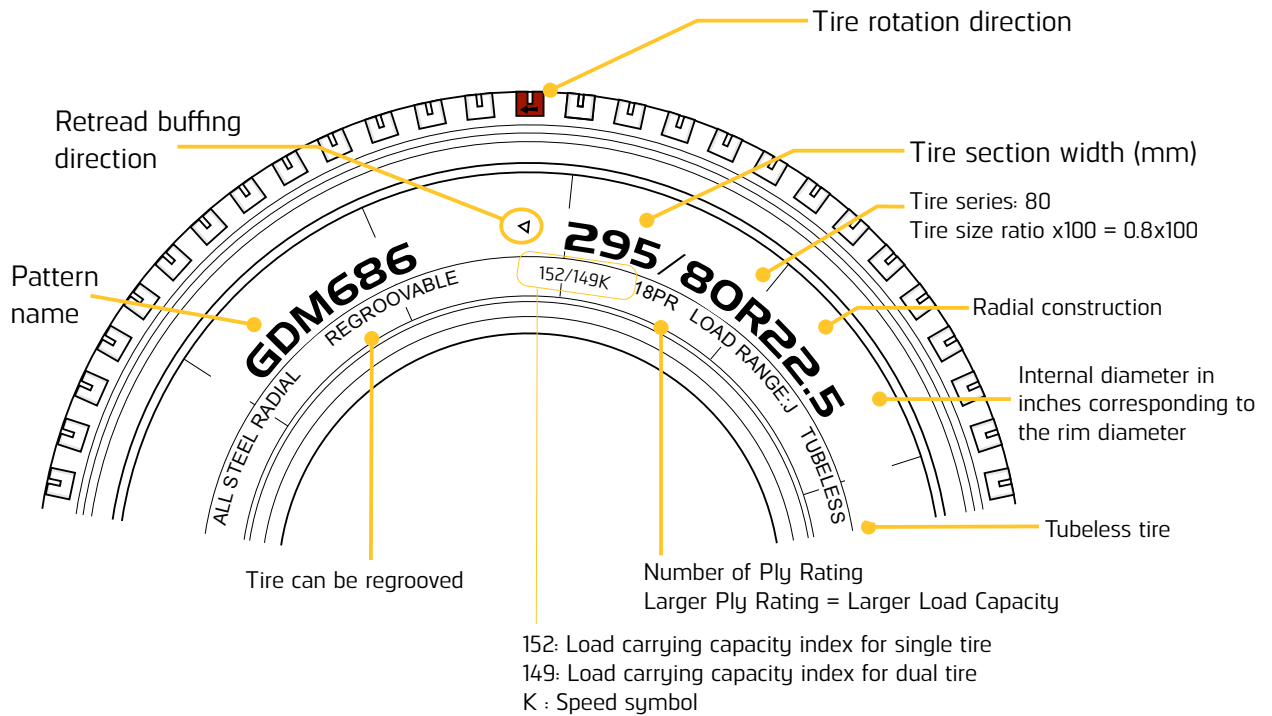

Refer to the Speed Symbols and Load Capacity Index tables below



Before fitting, it is essential to check the different markings to ensure that the tires meets the maximum load and speed possibilities and/or the regulations in force.

## Speed Symbols

SI	km/h
B	50
C	60
D	65
E	70
F	80
G	90
J	100
K	110
L	120
M	130
N	140
P	150
Q	160
R	170

## Load Capacity Index

LI	KG	LI	KG	LI	KG
115	1215	136	2240	157	4125
116	1250	137	2300	158	4250
117	1285	138	2360	159	4375
118	1320	139	2430	160	4500
119	1360	140	2500	161	4625
120	1400	141	2575	162	4750
121	1450	142	2650	163	4875
122	1500	143	2725	164	5000
123	1550	144	2800	165	5150
124	1600	145	2900	166	5300
125	1650	146	3000	167	5450
126	1700	147	3075	168	5600
127	1750	148	3150	169	5800
128	1800	149	3250	170	6000
129	1850	150	3350	171	6150
130	1900	151	3450	172	6300
131	1950	152	3550	173	6500
132	2000	153	3650	174	6700
133	2060	154	3750	175	6900
134	2120	155	3875	176	7100
135	2180	156	4000	177	7300

# Naming Conventions



**GSL213 (+)**

Brand	Axle	Application	Axle
G: Giti GT Radial	S:Steer D:Drive A:All position T:Trailer	L:Long Haul R:Regional M:Mixed Service O:Off Road U:Urban C:Coach W:Winter	2:Steer 6:Drive 8:All position 9:Trailer

Series Number

Symbol for Improvement

# BIAS and RADIAL TIRE COMPARISON

## Bias Tire Characteristics

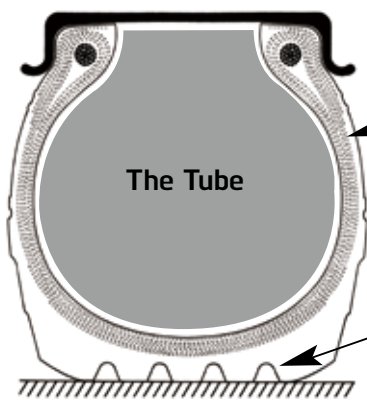

### The Casing

The casing of the tire is made of several cord layers. (can be between 12 to 16 or even more) crossing one and another.  
 Layer 1 2 3 in one direction  
 Layer 4 5 6 in the opposite direction

### The Tread Area

Is not stabilized.

The bead area is an extension and combination of the sidewalls.

Therefore, when the tire rolls all the deflections are transferred to the tread resulting in :  
 elliptical contact patch and uneven friction with the road surface.

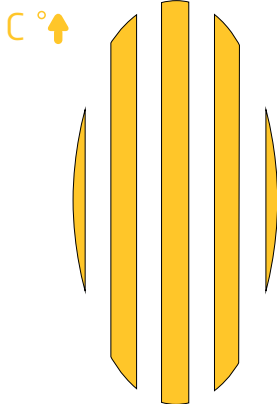
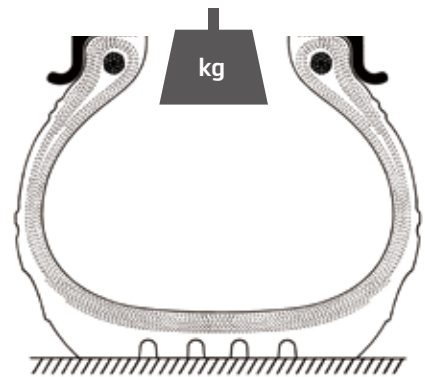

### The Disadvantages

This means that the result is

- Rapid wear
- Less grip/more skidding
- Less predictable handling(non-stabilized tread)
- Increased fuel consumption
- Increased heat generation from flexing and deforming

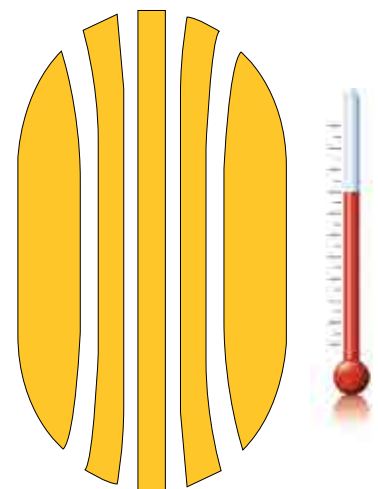

## BUT

If the vehicle operates on very bad road surfaces (non metallated) with heavy loads (+200%) at very low speeds  $\leq$  35kmh.

**Bias Tires can be a good solution.**

# Bias Tire Construction

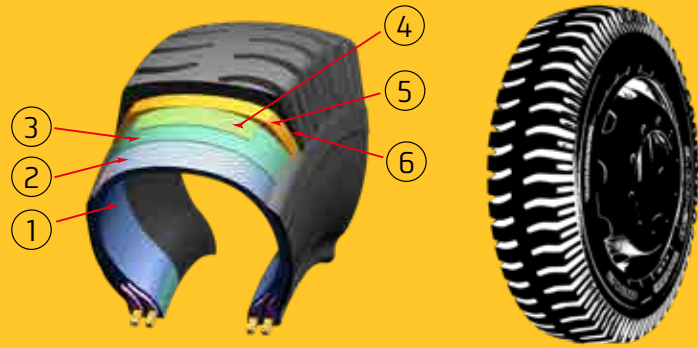

The Only Solution For 3 Decades!

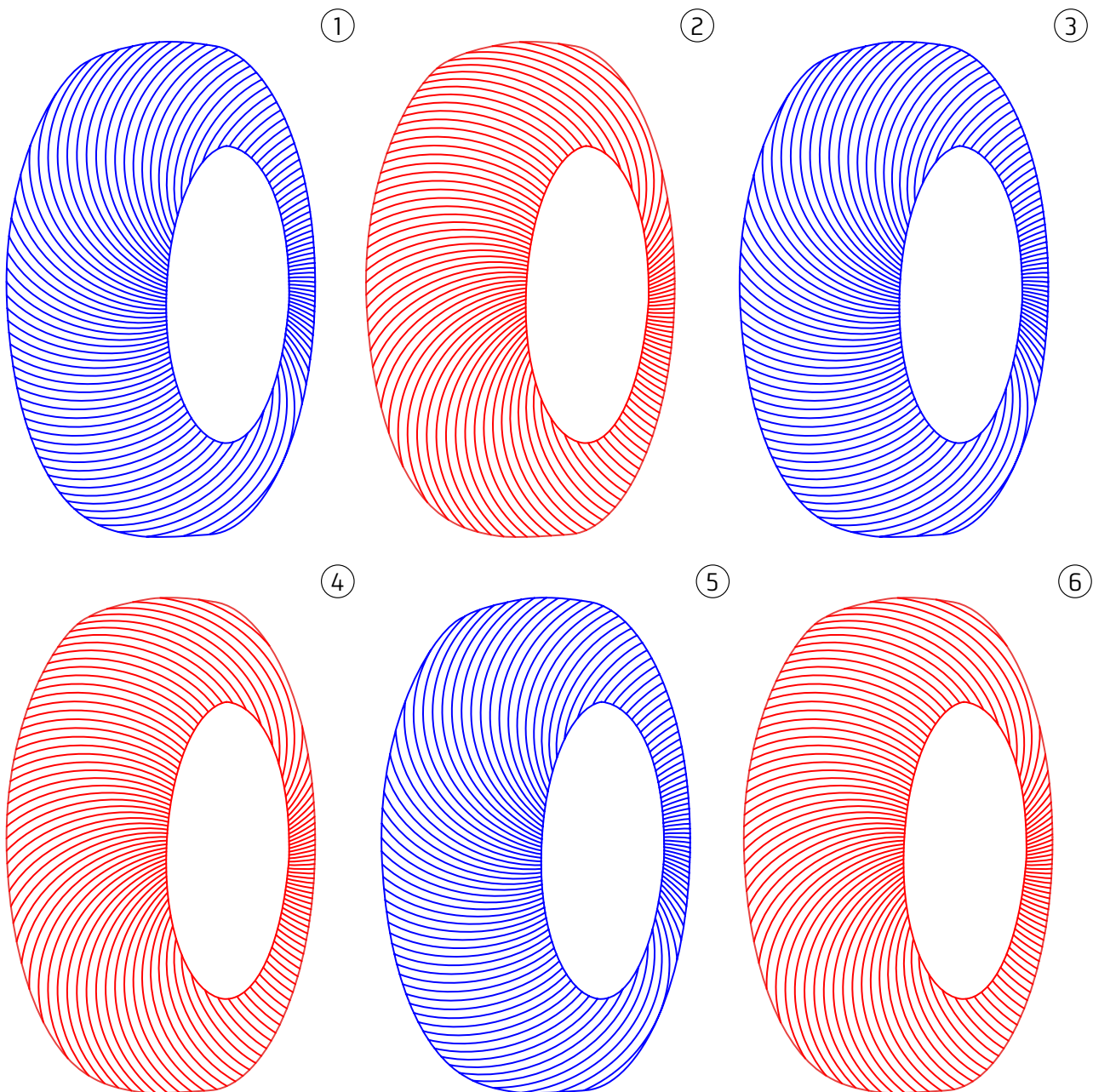



# BIAS and RADIAL TIRE COMPARISON

## Giti Tire Characteristics

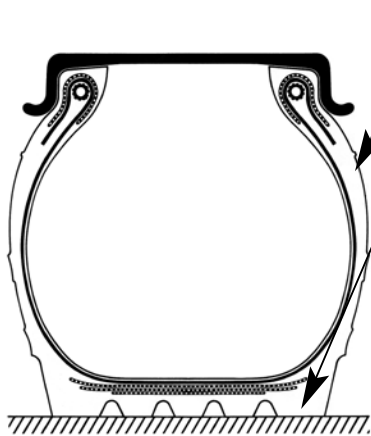

### The Casing

The casing of the tire is made up of a single ply of cables positioned at 90° to the direction of rotation and radial to the center of the tire.

### The Tread Area

The tread is stabilized by a separate tread belt made up of several plies 2-3 or 4. Each part of the tire, wall, and tread work independently of one another.

Therefore, as the tire rolls only the sidewalls flex: these deformations are not transmitted to the tread resulting in:

Reduced elliptical contact shape---more square shape, and hence firm contact with the ground

No displacement between the wall (as there is only one single steel casing ply cord)



### The Benefits of Giti Tires

- The advantages are significant increase in mileage! Can be up to 2.5 times bias equivalent
- Remarkable grip as the tire bead belts acts like a track machine (on an earthmover)
- Excellent grip and steering precision, thanks to the stabilized tread
- Improved fuel consumption, through lower rolling resistance
- Increased comfort and shock absorption, thanks to improved vertical flexibility
- Cooler temperature due to reduced casing friction and road contact friction

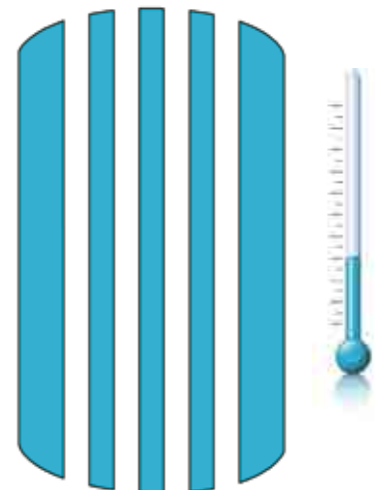

# Giti Tire Construction



The Technology Leader in Asia Pacific.  
The Future of Mobility!

①

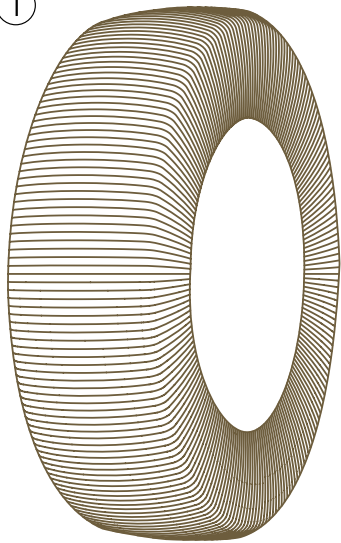

Casing Ply

②

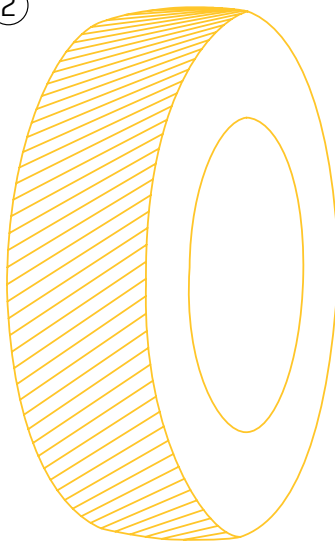

Transition Ply

③

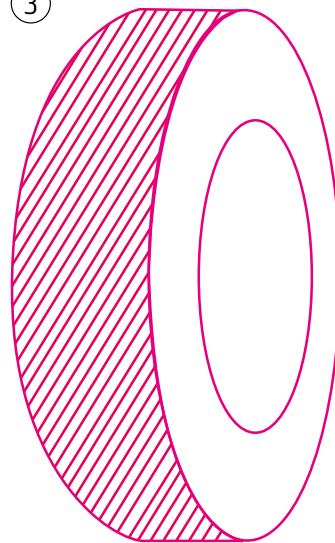

Stabilizer Ply A

④

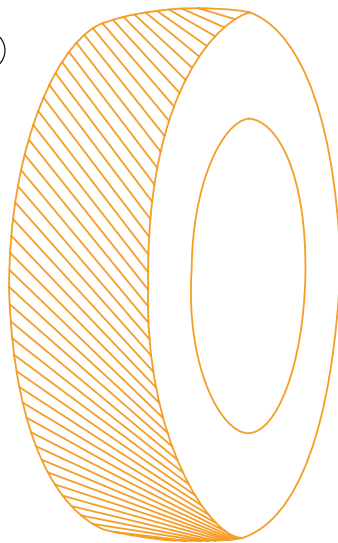

Stabilizer Ply B

⑤

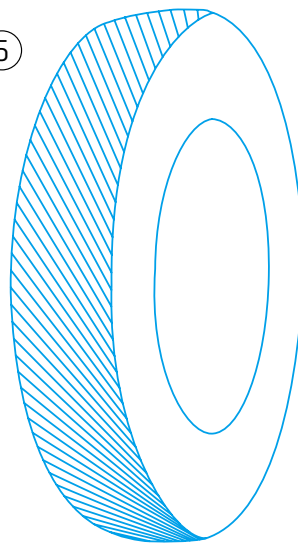

Protection Belt

# TUBE and TUBELESS TIRE COMPARISON

## Basic Components Of The Tube Tire

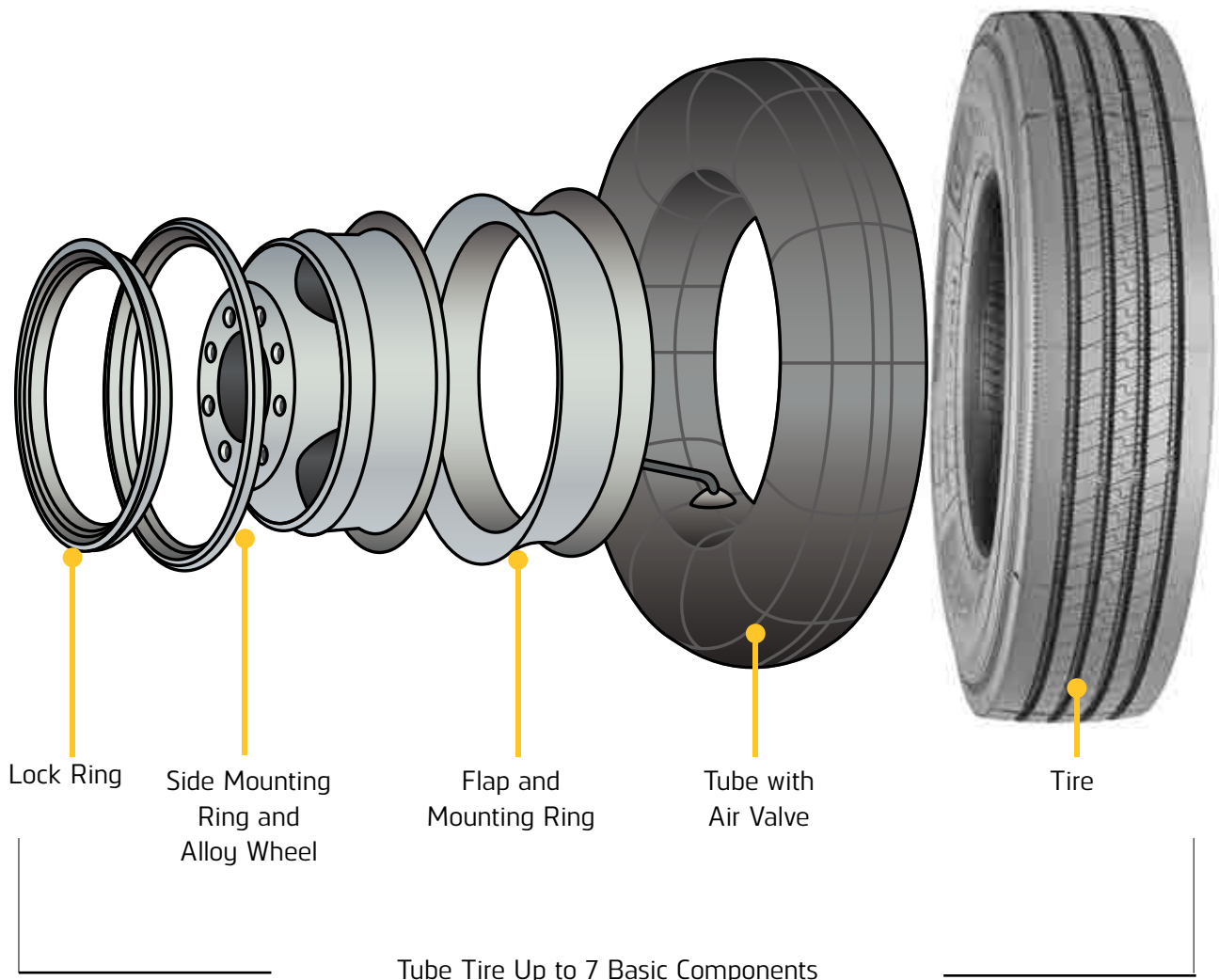

## Characteristics of Tube Tires:

- Steel wheel composed by 3 fitting parts with 50 years history of usage
- Tube tire composed by 5 fitting parts : outer tire, tube and air valve, flap, and copper ring
- Whole tube tire with alloy wheel compose of 7 fittings, easy to damage and cause abrasion with constant usage

## Giti Tire Characteristics

### Constraints of Tube Tires:

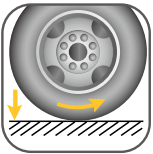

Many intergrating parts lower the rotating efficiency of the tire



Comparatively high fuel consumption



Inefficient heat dissipation increases the temperature of the tire during rotation and shortens the life span of the tire

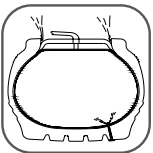

Fast air leakage if the tire punctures

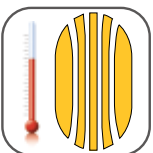

Tire tread surface contact with the ground is OVAL SHAPE, easy to get irregular wear



Increase the weight of the wheel with additional parts on the steel wheel

# TUBE and TUBELESS TIRE COMPARISON

## Basic Components Of The TUBE TYPE Tire

*GSR225 11.00R20 18 as example*

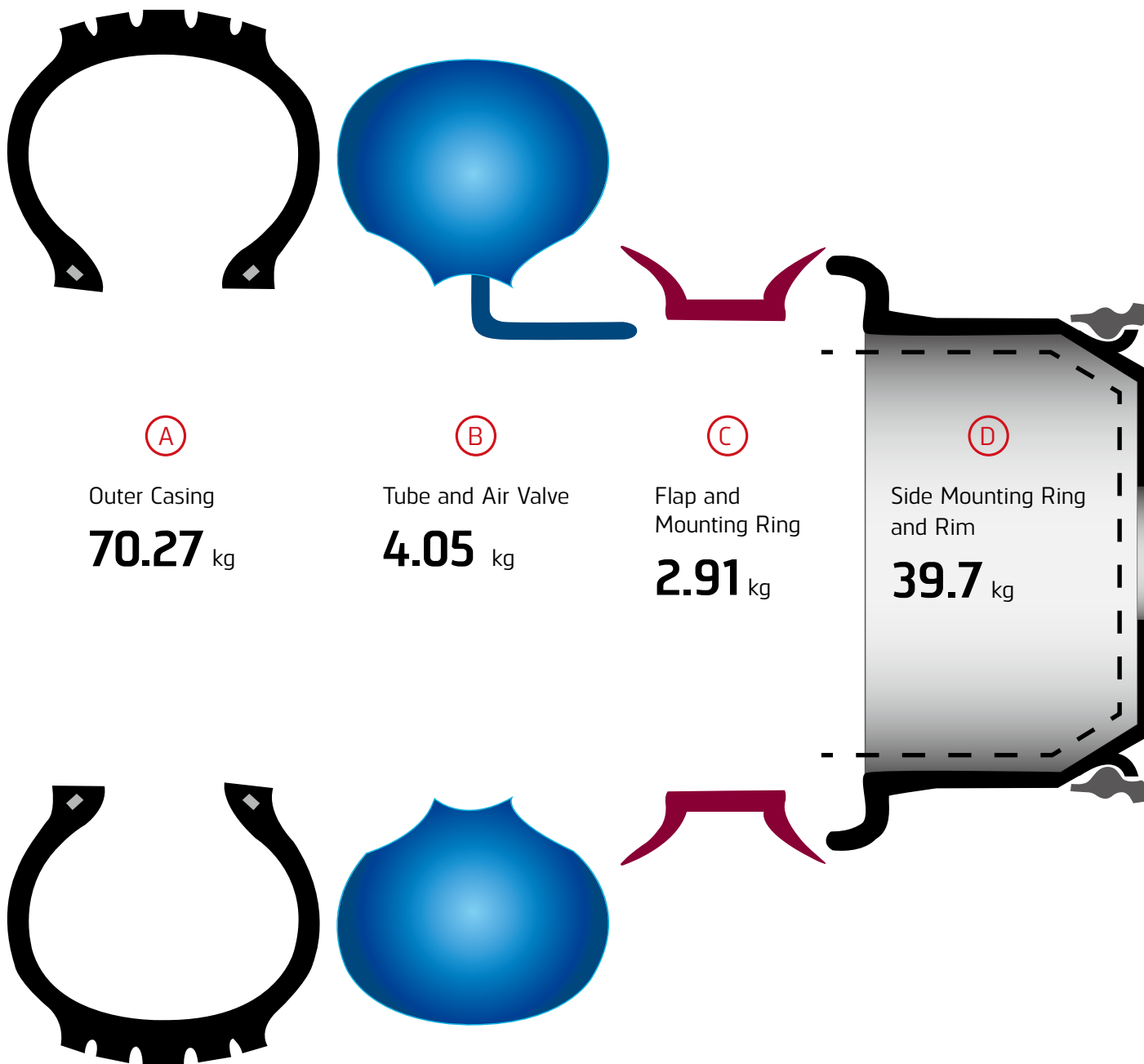

# TUBE and TUBELESS TIRE COMPARISON

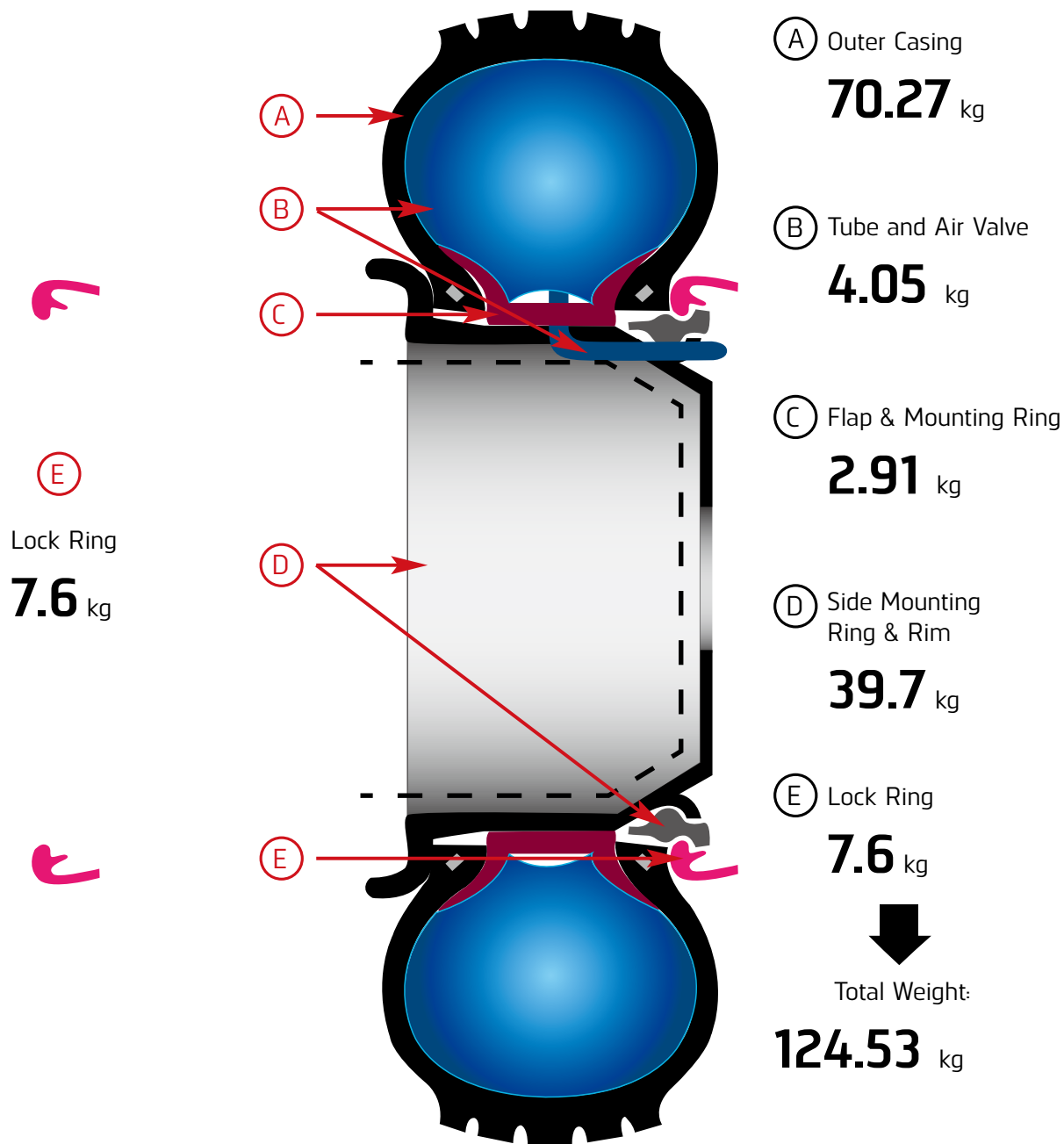

# TUBE and TUBELESS TIRE COMPARISON

## Basic Components Of The Tubeless Tire

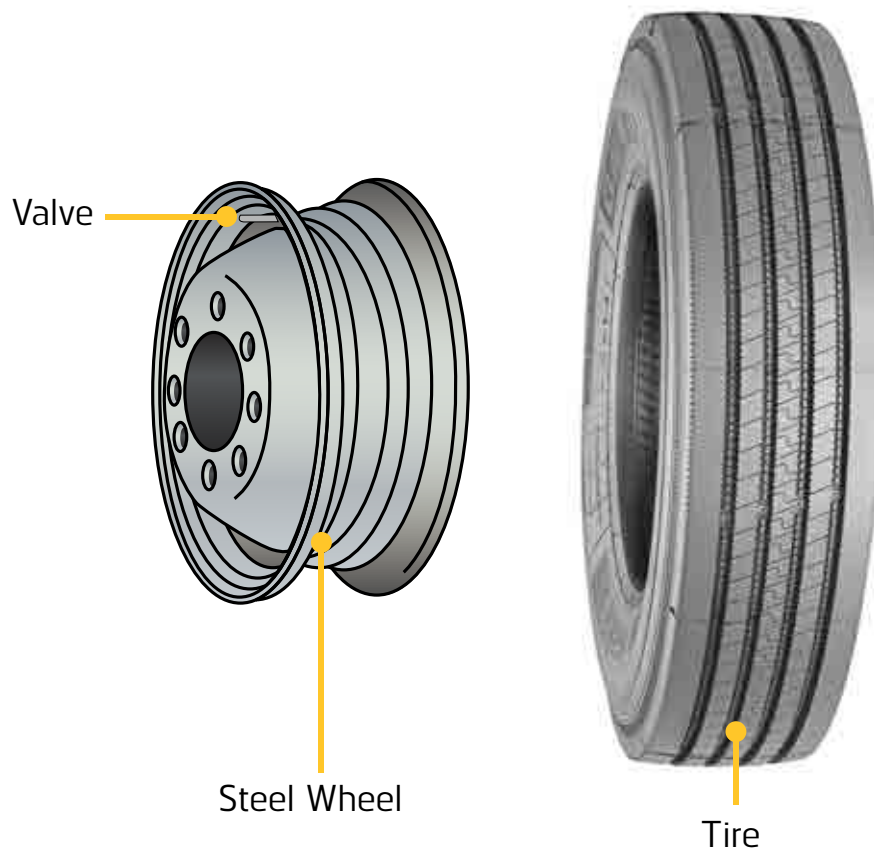

Tubeless Tire 3 Basic Components

## Characteristics of Tubeless Tire:

- Outer diameter is same as the tube tires, same efficiency and transmission ratio as tube tire is changed
- Diameter of the steel wheel increases 2 inches, excellent heat dissipation with lower temperature when tire is rolling
- No change on loading capacity, with lighter total weight of the tire and wheel

**10%**  
lighter  
compared to  
tube tires

## Advantages of Tubeless Tire:

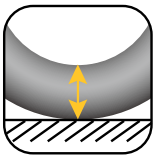

Lowering the depth of the tire sidewall, more agile and safe when driving



Lower abrasion and rolling resistance because of limited fitting parts. Excellent fuel efficiency



Excellent heat dissipation and low temperature when rolling. Extend the life span of the tire



Better contact with road surface, tire foot print more of a rectangular shape. Lower fuel consumption and extended tire life



Lower fuel consumption because of the light weight and limited fitting parts with reduced rolling resistance



# TUBE and TUBELESS TIRE COMPARISON

## Basic Components Of The TUBELESS Tire

*GAL817 12R22.5 18 as example*

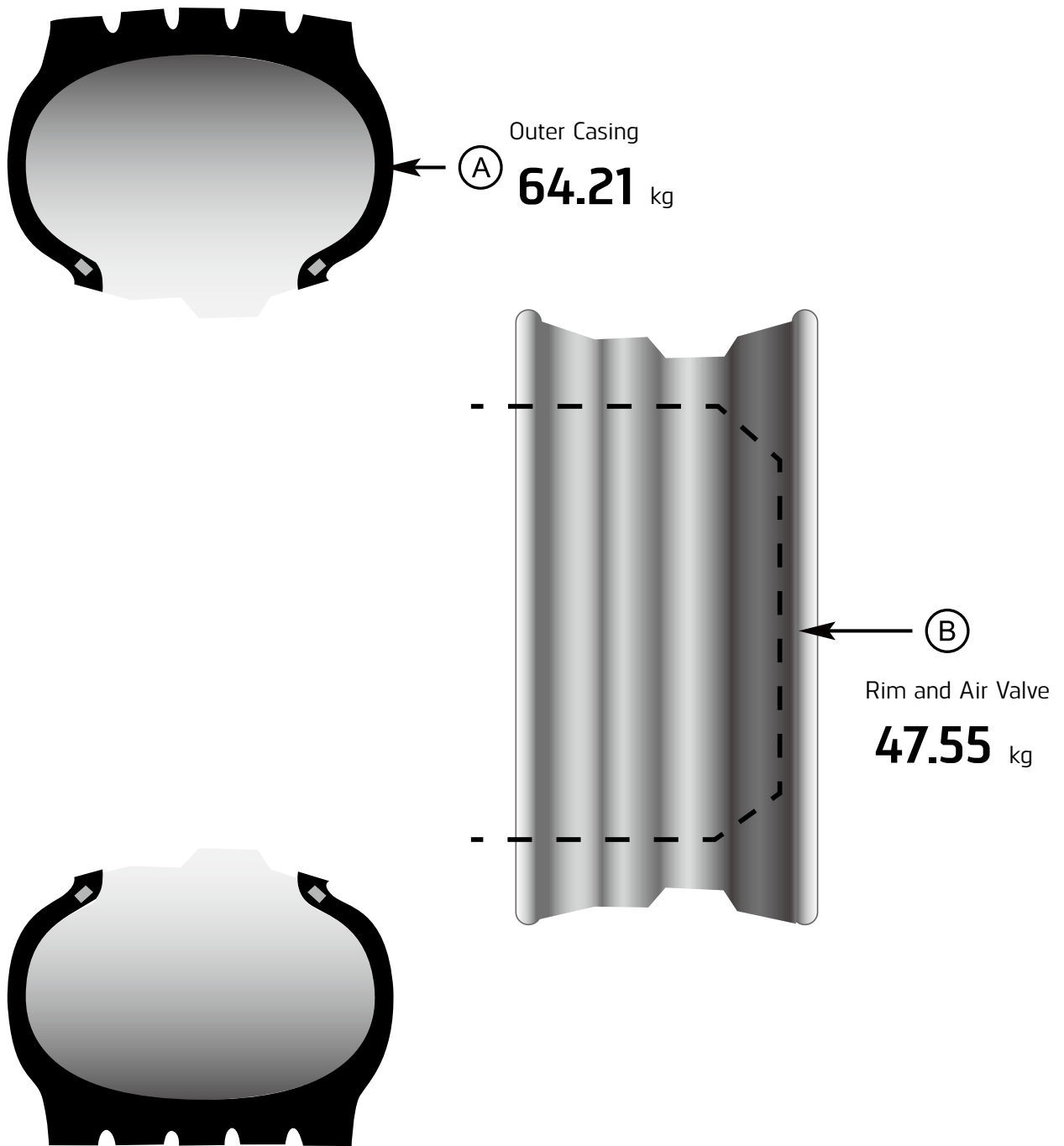

# TUBE and TUBELESS TIRE COMPARISON

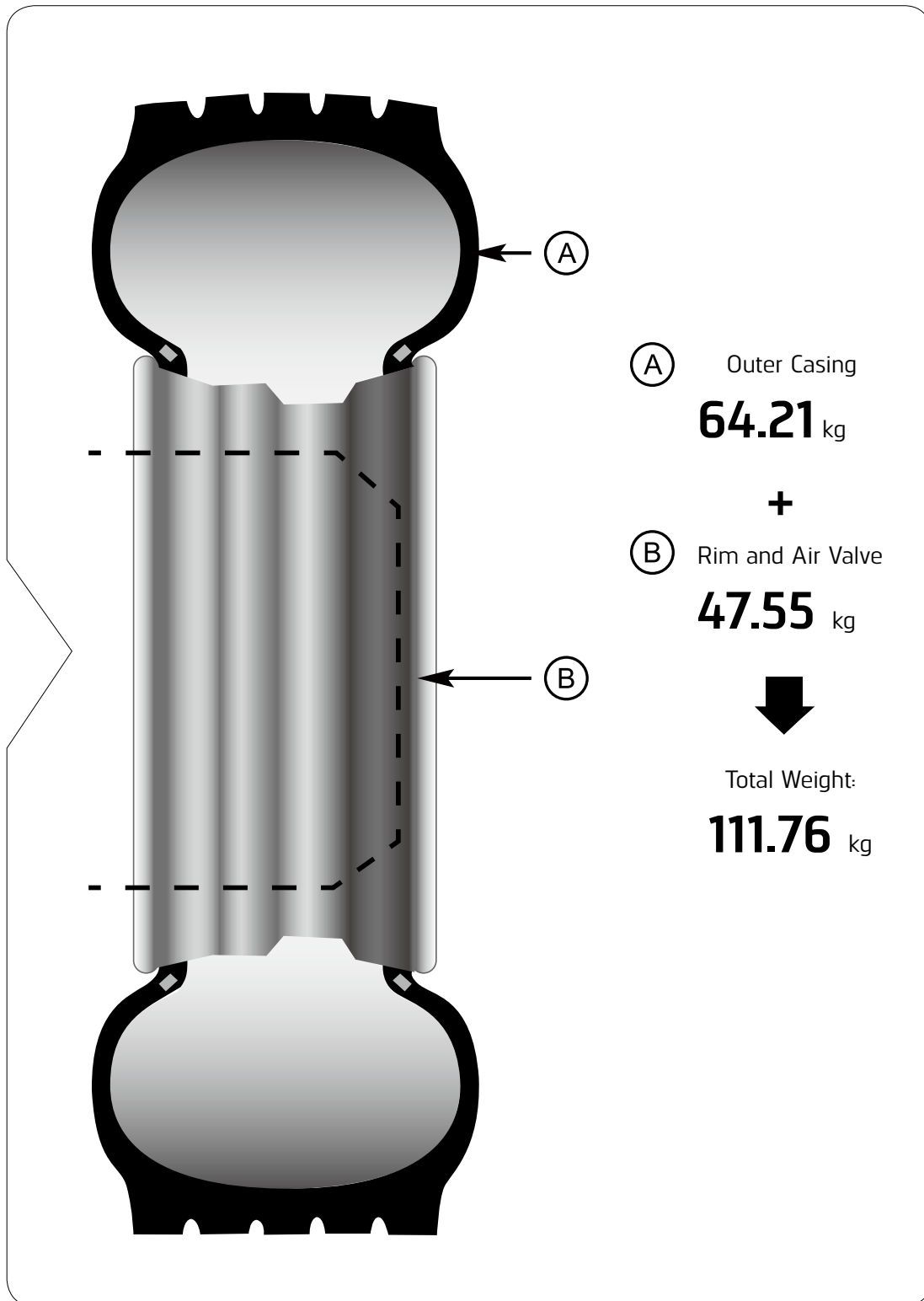



**Warnings:**

All vehicles are considered fully loaded or their Gross Vehicle Weight. Actual Gross Vehicle Weight should be compared with the load and inflation tables to determine the inflation pressure required. If the maximum load carrying capacity of the tire is below the actual weight, then, a tire with greater carrying capacity should be used. This means either a tire with a higher load capacity or a larger tire size. If the maximum load can be carried by the minimum pressure (as listed on the load inflation chart), then a smaller size tire or a lower capacity tire may be considered depending on the application and conditions of use of the vehicle.

The maximum load that can be put on a truck tire is dependent upon the specific design and load capacity assigned to the tire. For further information, refer to Giti Technical Information for complete information on allowable loads. Tires that are loaded beyond their maximum for the particular application will build-up excessive heat that may result in sudden tire destruction, property damage and personal injury.

Never mount tire on mismatch rims, rusty rims, and/or refabricated rims. This may cause the tire and rim assembly to explode during inflation, and during operations. Rim servicing must be done by experienced tiremen with proper protective gears and tools.

## **Section 6**

# **Tire Management, Care & Maintenance**

# Six Steps to Simple Tire Maintenance

- S**elect the correct tire for your operating conditions (Don't forget to select for new vehicles too!)
- I**nflate your tires corresponding to the **LOAD** per **AXLE** (See load Inflation tables)
- M**aintain your tires by regular inspection and performance monitoring. (Don't forget the inflation pressure, tread, and sidewalls too)
- P**rotect your investment in Giti Group products by retreading the casing. (Our tires are designed to have more than one life)
- L**ower your running costs by managing your tires carefully, you may get further retreading opportunities by **GOOD TIRE MANAGEMENT**
- E**njoy ongoing cost savings from Giti Group

# Tire Pressure Management

## Inflation Pressure Recommendation

### ! SAFETY

Important instructions for safe inflation



**Over-inflation reduces**

- Comfort
- Grip
- Braking distance
- Tire life span, particularly on Drive axle tires
- Safety

**Under-inflation leads to**

- Reduced vehicle handling and safety
- A reduction in casing retreadability
- An increase of rolling resistance consequently of fuel consumption

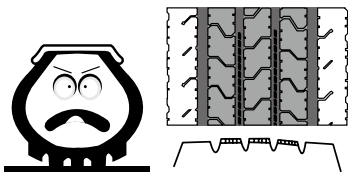

Over-inflation

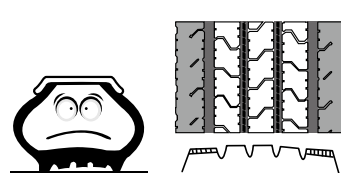

Under-inflation

Effect of inflation pressure on tire life

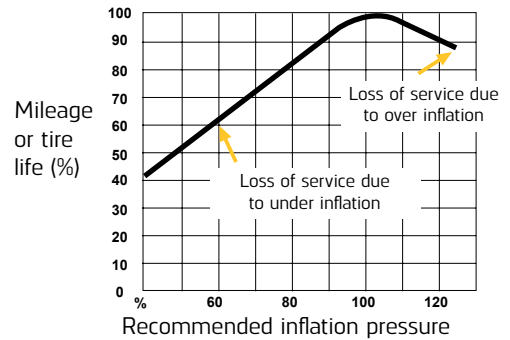

### ADVICE BEFORE INFLATION

- 1 Weigh your vehicle and its load, axle by axle, to determine tire pressure.
- 2 Measure the pressure when cold (when the vehicle has been stationary for several hours); pressures must be checked at regular intervals and during each service.
- 3 Important safety instruction: pressure increases when the vehicle is in motion, never reduce the pressure of a hot tire.
- 4 Pressure gauges: must be accurate, handled with care and calibrated regularly



#### Caution-

Driving with insufficient pressure can damage your tires. After having Driven with an underinflated tire, do not re-inflate tires: have your tires fully checked by an expert.

### INFLATION METHOD



#### With inflation cage

- Place the tire vertically in the inflation cage
- Read the cage user manual



#### Without inflation cage

##### Step1

Pre-inflate tire up to 1.5 bars, and STOP

Check the tire. If in doubt, stop and call an expert.

##### Step2

Inflate up to the appropriate pressure.

3m During inflation, stand in line with the tire tread three meters away

# Tire Pressure Management

## Why Should We Perform Regular Tire Pressure Checks?

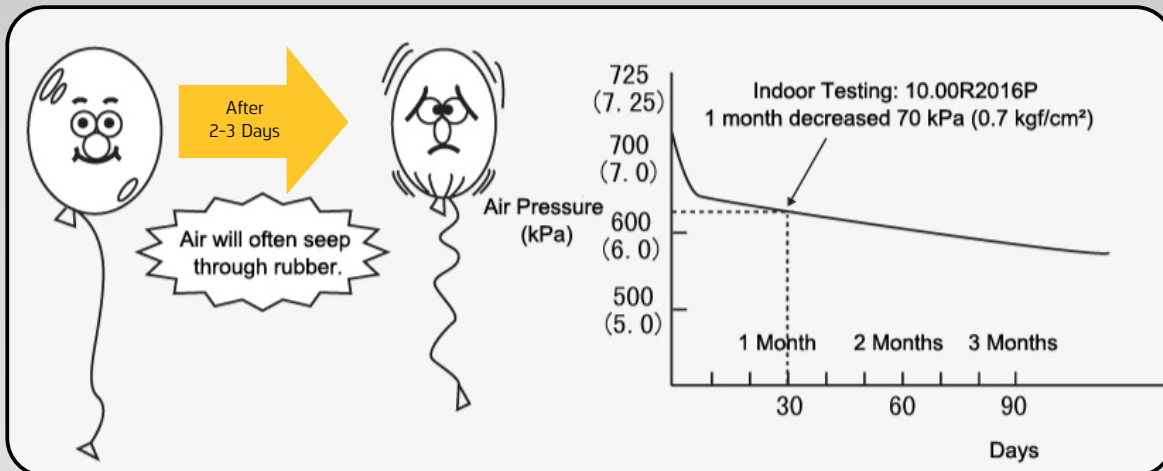

Tire Pressure will naturally decrease over time. New tire will decrease 70 kPa (0.7 kg/cm<sup>2</sup>) within a month.

**Importance of Regular Tire Pressure Inspection**

## Dangers of Low Tire Pressure

- Abnormal Shoulder Wear On Both Sides
- Deformed Sidewalls (Steel Wire Detaches From Rubber)
- Sidewalls Easily Broken
- Increased Fuel Consumption

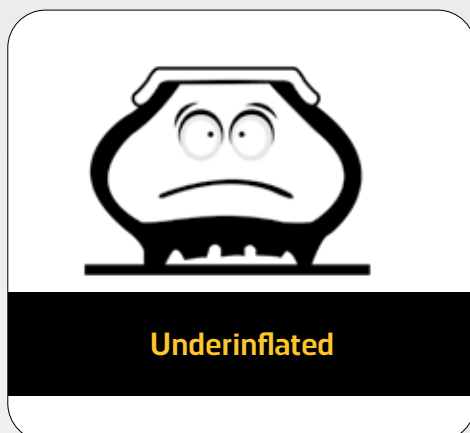

**Serious Underinflation**

# Tire Pressure Management

## Tire Damage

- Decreased buffering capacity and shock resistance leads to more broken steel wires or tire blowouts
- Smaller contact area between tire and the ground leads to faster wear, especially in the center, resulting in shorter tire life
- Increased skidding

## Road Damage

- High tire pressure without overloading, will damage the road due to the effects of force and counterforce

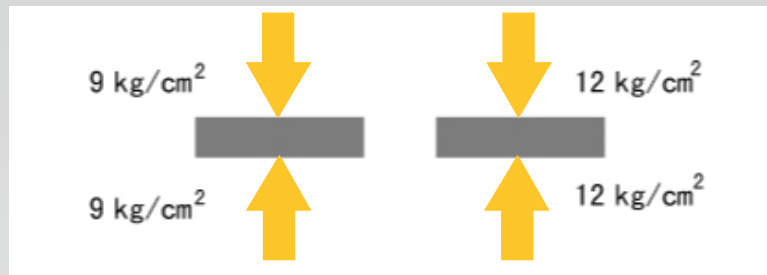

## Road Damage

- High tire pressure causes greater vibration which leads to rim damage



## Vehicle Component Damage

- High tire pressure increases vibrations and damages vehicle components, while proper tire pressure has better buffering capacity

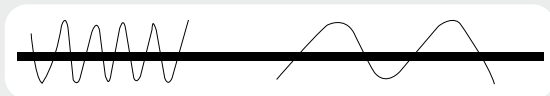

When the tire pressure is maintained at 10kg/cm<sup>2</sup>, tire life can be extended by 40%

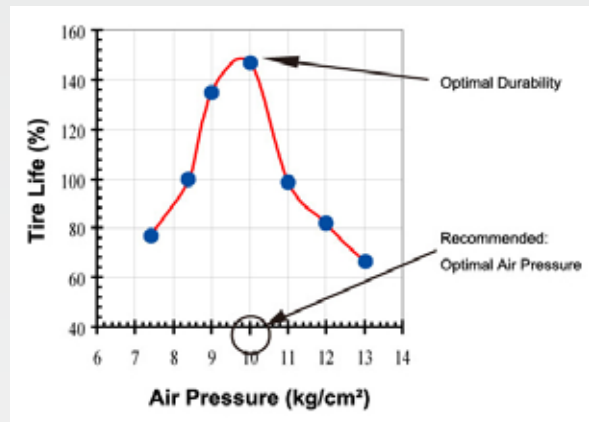



# Wheel Alignment/Toe-Setting

## Results of Inappropriate Wheel Alignment/Toe-Setting

Inappropriate wheel alignment/toe-setting could result in too much toe-out or toe-in.

**1 mm** of toe deviation will force a truck and bus tire sideways by **7m/km**.

1. Leading to severe shoulder wear (as illustrated below in red).
2. Adding fuel cost. Fuel consumption is **3%** higher for every **1 mm** toe deviation.

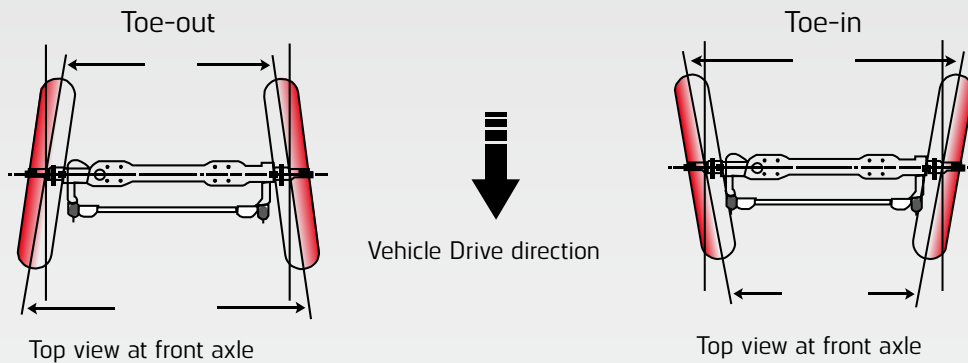
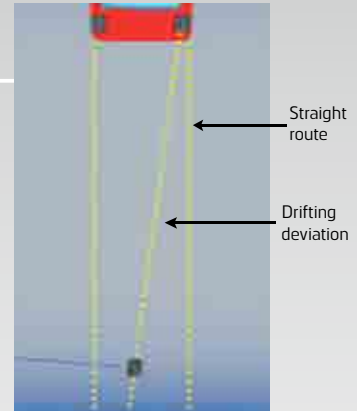

## Tire Wear Caused by Inappropriate Wheel Alignment/Toe-in



Tire shoulder wears faster



Tread ribs worn feather-like

Once irregular wear is spotted, the wheel toe deviation is probably above 3 mm.

**Note.** In preference please set the wheels parallel, or as near to parallel as the vehicle manufacturer allows.

# Technical Specification

-  **S** Tire Section
-  **H** Tire Height
-  **R** Unloaded Free Diameter
-  **R'** Loaded Deflected Radius
-  **D** Rolling Circumference
-  **E** Min. Distance Tire Sidewalls in Twin Fitment
-  **T** Tread Depth

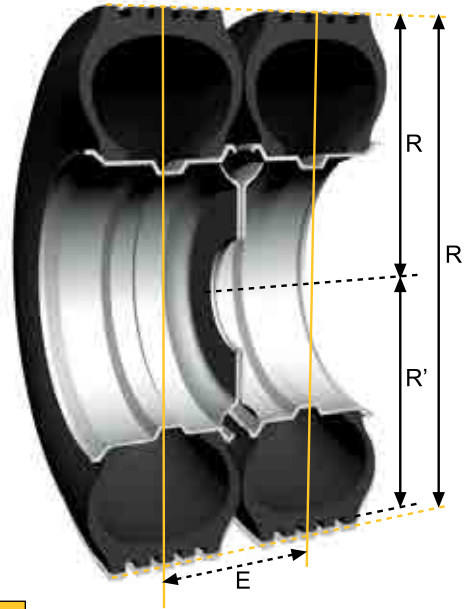
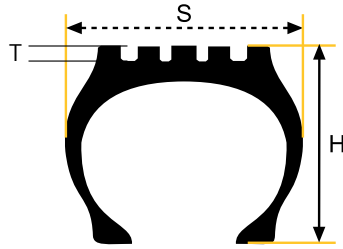

## Load Capacity Variations According to Speed

Speed (km/h)	Load Capacity Variation(%)						Pressure Balance(%)
	F	G	J	K	L	M	
0	+150	+150	+150	+150	+150	+150	40
5	+110	+110	+110	+110	+110	+110	40
10	+80	+80	+80	+80	+80	+80	30
15	+65	+65	+65	+65	+65	+65	25
20	+50	+50	+50	+50	+50	+50	21
25	+35	+35	+35	+35	+35	+35	17
30	+25	+25	+25	+25	+25	+25	13
35	+19	+19	+19	+19	+19	+19	11
40	+15	+15	+15	+15	+15	+15	10
45	+13	+13	+13	+13	+13	+13	9
50	+12	+12	+12	+12	+12	+12	8
55	+11	+11	+11	+11	+11	+11	7
60	+10	+10	+10	+10	+10	+10	6
65	+7.5	+8.5	+8.5	+8.5	+8.5	+8.5	4
70	+5.0	+7.0	+7.0	+7.0	+7.0	+7.0	2
75	+2.5	+5.5	+5.5	+5.5	+5.5	+5.5	1
80	[0]	4.0	+4.0	+4.0	+4.0	+4.0	0
85		2.0	+3.0	+3.0	+3.0	+3.0	0
90		[0]	+2.0	+2.0	+2.0	+2.0	0
95			+1.0	+1.0	+1.0	+1.0	0
100			[0]	0	0	0	0
110				[0]	0	0	0
120					[0]	0	0
130						[0]	0

The coefficients in this table are those of the ETRTO standard and are given for information only.

Contact us for all load capacities greater than the basic load limits given by tire markings and used in this brochure. When the coefficients in these tables lead to pressure greater than 10 bars, you must reduce the maximum load capacity to an amount which corresponds to a maximum pressure of 10 bars.

If you wish to use pressure greater than 10 bars, consult us for the tires, check the maximum resistance of rims with your rim manufacturer and comply with regulations in force for fitting and use. The coefficients indicated in this table are taken from the ETRTO.

# Tire Rotation Management

## Points for Attention

- Change revolution direction if tread pattern is not unidirectional
- Rotate front wheels, trailer wheels, and Drive wheels
- Have higher frequency for tire rotation during early wear stage

(Example of standard load long haul truck user)

The same user prepares 3 test vehicles for tire rotation with wear rate 20%, 40%, 60% respectively. Analyze the best rotation method (Example of 2-D vehicle model: load rate 100-130% speed 80km/h)

Comprehensive life		* Cost per km
Tires Rotated	122	84
Tires Not Rotated	100	100

*\*Including expense needed for life extension and 2 times of rotation*

Typical example  
of tire wear

### Irregular wear for tires not rotated

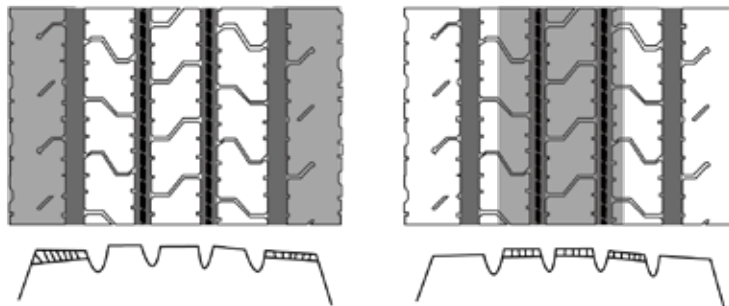

Shoulder wear - Two sides

Central wear



Position

Position for irregular wear

# Tire Rotation Management

## Tire Rotation (to increase mileage)

Due to concerns of damage to tire shoulder and bead in heavy duty transport, proper tire rotation can extend service life of tire.

(Position Exchange)

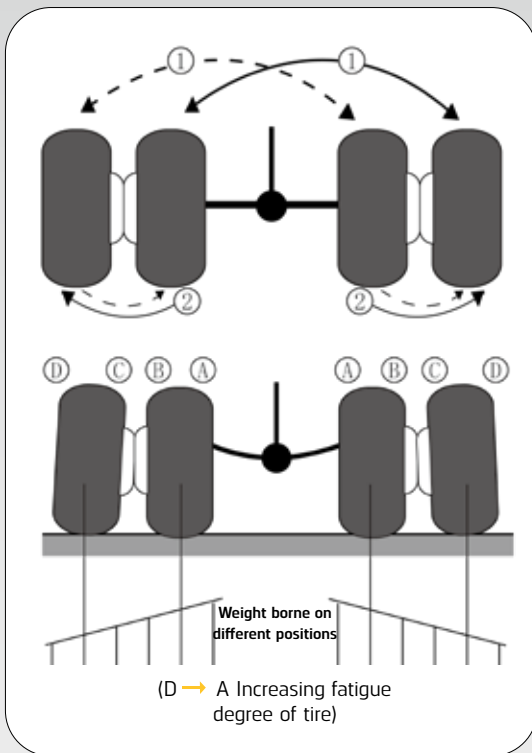

- The first position exchange 2-3 times of rotation before complete wearout of tire
- The second position exchange

\*It is better to rotate to other axle.

In dual tire use, weight on inside tire is relatively big generally and heat absorbed from brake drum is relatively high due to less ventilation.

(Effect of Position Exchange)

(Overload Example)

Load: 180-320% 40-50 km/h Life performance before damage

	Life Performance	Wear Rate	Life Index
Position Exchanged	49.700 km	82%	260%
Position Fixed	19.100 km	37%	100%

# Essential Safety Information

## Pressure of Inflation

The inflation pressures of tires for commercial vehicles must be adapted to the load, speed and conditions of use. Respecting the pressure of inflation is a prime factor in ensuring that the vehicle is safe when driving.

How do I Determine the Pressure of Inflation?

The fully loaded vehicle must be weighed by axle:

- Over inflation is bad for comfort, grip, and the tire's longevity...
- Insufficient pressure leads to an abnormal rise in the tire's temperature, leading to irreversible deterioration of its inner parts. This may cause destruction of the tire with a sudden blow-out.

The consequences of running with insufficient pressure of inflation are not necessarily immediate and may even become apparent after correction. The pressure of inflation should be regularly checked "when cold" each time the vehicle returns to the garage using an accurate and regularly checked pressure gauge (according to the maker's recommendations). When operating in very cold temperatures, consult the Giti Truck Bus Tire Service Manual for correct inflation procedures. Additionally, altitude can have a slight effect on air pressure. For every 300 meters increase in altitude above sea level, air pressure will increase approximately 0.5 psi.



### Important-

- Don't forget the spare tire
- Never deflate a tire "when hot" just after running



**WARNING-** Any inflated tire mounted on a rim contains explosive energy. The use of damaged, mismatched or improperly assembled tire/rim parts can cause the assembly to burst apart with explosive force. If you are struck by an exploding tire, rim part or the air blast, you can be seriously injured or killed.



**WARNING-** Tire and rim servicing can be dangerous and must be done only by trained personnel using proper tools and procedures. Failure to read and comply with all procedures may result in serious injury or death to you or others. Re-inflation of any type of tire and rim assembly that has been operated in a run-flat or underinflated condition (80% or less of recommended operating pressure) can result in serious injury or death. The tire may be damaged on the inside and can explode while you are adding air. The rim parts may be worn, damaged or dislodged and can explosively separate. A Tire running underinflated should not be returned to service until the interior is carefully inspected. The weight by axle under load is the only way to determine the right pressure of the interior of the tire by a specialist.

# Essential Safety Information

## Inflation Pressure

The most critical factor in tire maintenance is proper inflation. No tire or tube is completely impervious to loss of air pressure. To avoid the hazards of under inflation, lost-air must be replaced. Inflation pressure has a direct impact in tire performance - both tread life and endurance - as shown in the following charts:

### Pressure Effects on Tread Life

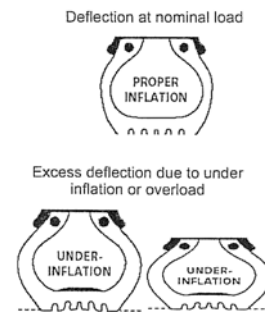
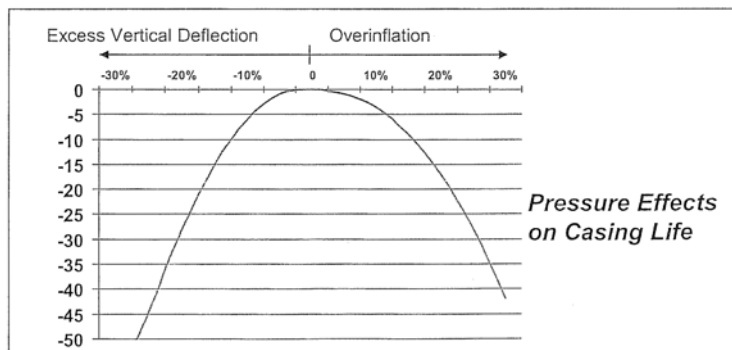
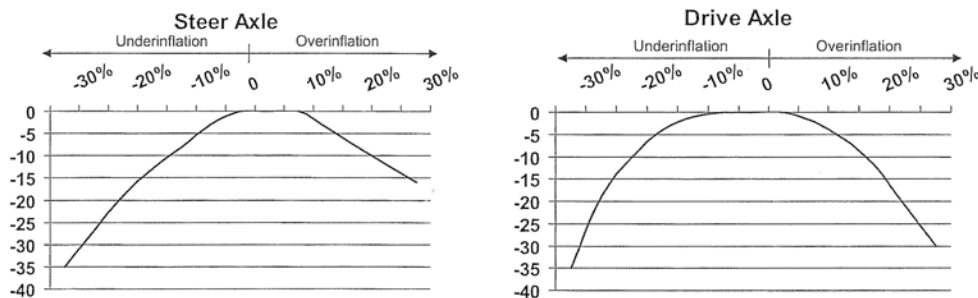

**WARNING.** Driving on any tire that does not have the correct inflation pressure is dangerous and will cause tire damage. Any under inflated tire builds up excessive heat that may result in sudden tire destruction. Pressures which are too high can lead to more rapid and uneven wear as well as being more vulnerable to road hazard damage. Consult a Giti tire dealer or Technical Data Book for the proper inflation pressures for your application.

### Influence on Cost

Correct Pressure	20% Underinflation (steer)	20% Overload
Price: 100%	Price: 100%	Price: 100%
Mileage: 100%	Mileage: 85%	Costing Life: 73%
<b>Ratio of Cost / km</b>		
$\frac{\text{Invested Capital} = 100\%}{\text{Mileage} = 100\%} = 1$	$\frac{\text{Invested Capital} = 100\%}{\text{Mileage} = 85\%} = 1.17$	$\frac{\text{Invested Capital} = 100\%}{\text{Cosing Life} = 73\%} = 1.37$
<b>Correct = 100%</b>	<b>Extra Cost = 17%</b>	<b>Extra Cost = 37%</b>

# Tire Mounting/Demounting

## TUBE Tire Mounting/Demounting (manually)



### Step 1

The tire and tube should be cleared of debris before assembly. It is recommended to apply dry and finely ground talc or graphite powder uniformly on the surface of the tire inner wall, tube, and flap.



### Step 5

Insert the ring (compression ring) into the groove.



### Step 2

When placing the folded tube into the tire, the valve stem must be face upwards. Unfold and flatten the inner tube when inserting it into the tire. Remove the tube valve cap.



### Step 6

Make sure all the components are properly installed and match with each other. Remove the tube valve core and inflate the tire pressure to the recommended 350 kPa. Using a wooden mallet, tap along the tire circumference so that the tire fits tightly with the rim.



### Step 3

Check if the flap is assembled in the correct position. Set the flap on the tube valve stem, between the tube and the tire. Make sure there are no wrinkles or folds on the flap edge.



### Step 7

Check to see if the tire is installed correctly. If not, deflate the tire and readjust the position of the tire and the rim.



### Step 4

Apply noncorrosive lubricants uniformly on the bead. Install the tire onto the rim, aligning the valve with the rim valve slot.



### Step 8

After the tire is assembled, check to see that each component is installed properly before inflating the tire. Then inflate the tire to the specified pressure level and measure with a pressure gauge.

## Reminder.

- Tire must be mounted to rim stipulated in relevant standards. Rim should not have problems like deformation, corrosion, out-of-roundness, crack, lack of weld, burnout, uneven welding, fuzzing, sharp edge, etc.
- The same vehicle should be fitted with tires of the same specification, structure, make, size, PR, and pattern.
- When directional pattern tire is mounted, rotation direction mark of tire should comply with vehicle Drive direction.
- When new tire is fitted, try to change all tire for the whole vehicle or the same axle as much as possible.
- When tube tire is mounted/demounted, special tool or machinery should be applied.

# Tire Mounting/Demounting

## TUBELESS Tire Mounting/Demounting (mechanically)



### Step 1

Choose the correct rim size and model for your tire. It is recommended to replace the rim if there are damages or cracks.



### Step 6

Use lubricants to protect the tire from damage. Lubricate the bead and rim edge uniformly.



### Step 2

Clean the rim with clean cotton towels.



### Step 7

Align the balance point (white dot) with the valve. Tilt the tire to place it onto the rim, and fix the rim in place using splints.



### Step 3

Tighten the valve stem cap to prevent the valve from loosening and leaking air.



### Step 8

Insert the indenter from the bottom of the rim and rotate the main axle clockwise. Never install both beads at the same time to avoid bead damage.



### Step 4

Apply noncorrosive lubricants uniformly on the bead. Install the tire onto the rim by aligning the valve with the rim valve slot.



### Step 9

Inflate the tire to the recommended pressure of 350 kPa. Check to see if the tire is installed correctly (tire line matches up with rim edge). If not, deflate the tire and readjust the position of the tire and the rim.



### Step 5

Check if the tire is damaged or cracked. If so, replace or repair the tire immediately. Clean the tire (recommend using special tire cleaners) by wiping off the moisture or debris inside the tire with a clean cotton towel.



### Step 10

After the tire is assembled, check to see that each component is installed properly before inflating the tire. Then inflate the tire to the specified pressure level and measure with a pressure gauge. During tire inflation, the operator should not stand to the side of the tire.



# Tire Mounting/Demounting

## TUBELESS Tire Mounting/Demounting (manually)



**Step 1**  
Inspect rim for excessive wear or damage. Correctly position and properly torque the valve stem.



**Step 6**  
If necessary, continue to work the first bead on with proper tubeless tire tools.



**Step 2**  
Fully lubricate both flanges and the drop center.



**Step 7**  
Mount second bead using same method. Use the proper tool, not the duck bill hammer.



**Step 3**  
Fully lubricate both beads and the inside of the bead that will be the last one mounted.



**Step 8**  
With assembly horizontal, inflate to no more than 5 psi to seat the beads.



**Step 4**  
Place rim in correct position, short side up (drop center up).



**Step 9**  
Place the assembly in the safety cage for safe inflation.



**Step 5**  
Do not use your knee to place the tire; use proper tools. Place the tire on the wheel using a rocking motion with adequate downward pressure. (the bottom bead may drop over the wheel flange).



**Step 10**  
Use a clip-on chuck.

# Simple Tubeless Tire Repair Technique



**Step 1**  
First, inspect the tire thoroughly to determine if it is repairable.



**Step 7**  
Align the center of the repair material with the center of the damage, and draw a peripheral line 25 mm beyond the repair material as the buffing line.



**Step 2**  
If any damage is found, mark the position both inside and outside with a crayon.



**Step 8**  
Spray the area with a rubber cleaner.



**Step 3**  
Remove the foreign object that caused the damage.

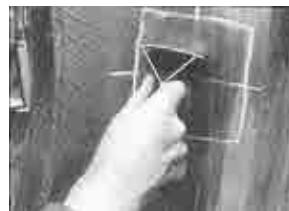

**Step 9**  
When the tire is still wet, scrape off the foreign objects with a scraper.



**Step 4**  
Check if there is any hidden damage inside or outside with a puncture probe.



**Step 10**  
Use a rubber buffing wheel and a low-speed pneumatic buffing machine to buff the previously marked area.



**Step 5**  
Determine the damage angle from inside out with a drill bit.



**Step 11**  
Use a carbide cutter and a low-speed pneumatic drill to cut along the damaged area from inside to outside in a clockwise direction for at least three times.



**Step 6**  
If the damage is greater than 25°, use the two part separation method to repair. If the diameter of the damage is within 15 mm, use an integral radial plug.



**Step 12**  
Repeat step 11 from outside to inside for three times to make sure the damaged area is properly treated.

# Simple Tubeless Tire Repair Technique



## Step 13

Use a vacuum cleaner to remove the steel slag and scrap rubber on both sides of the tire.



## Step 19

Remove the blue film from the crown and reposition it (see picture). This is to avoid unnecessary adhesion during the pulling process and contamination of the grey cushion gum.



## Step 14\*

Use the rubber cleaner and a clean cloth to remove the contaminants by wiping the tire outward from the center. Repeat this step until the buffed area is completely clean. Wait 3-4 minutes for the cleaner to completely dry.



## Step 20\*

Position the integral radial plug horizontally, and apply the curing agent on the cone part of the rubber stem and on the edge of the gray adhesive.



## Step 15\*

With a brush, apply the curing agent both inside and outside the buffed hole.



## Step 21

Drill the steel string puller through the hole paying special attention to the alignment of the arrow with the tire toe.



## Step 16\*

Apply the curing agent on the buffed area outward from the center, and wait 3-5 minutes for it to dry.



## Step 22\*

Pull the steel string puller from the inside out so that the integral radial plug is secured in place.



## Step 17

Position the steel string puller around the middle of the exposed black rubber stem.



## Step 23

After the rubber stem is pulled out of the hole, check if arrow 5 is aligned with the tire toe. Continue pulling until the reinforced crown is pressed against the inner tire surface.



## Step 18

Remove the blue film wrapping the rubber stem.



## Step 24

Use your thumb to press the crown into position.

# Simple Tubeless Tire Repair Technique



## Step 25

Use a compaction roller to secure the crown in place from the center out.

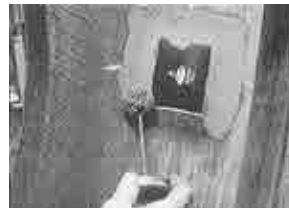

## Step 28\*

Apply safety sealant to the crown and along the polished site when tubeless tire is repaired.



## Step 26

Remove the blue film and repeat the step above until the crown is completely compacted.



## Step 29

Cut the rubber stem so that it is leveled with the tread. If the rubber stem is in the groove, use a carving machine to carve it so that it matches the tread.



## Step 27

Remove the white film.



## Step 30

The repair process is completed, and the tire can now be put back into service.

\* or equivalent

## Crown Repair Limit

- Decide repair for damage with 1-2 cm diameter to long haul and urban vehicle tire based on specification.
- Tire repair for long haul shall not exceed 1 cm of crown diameter.
- Non repairable area.

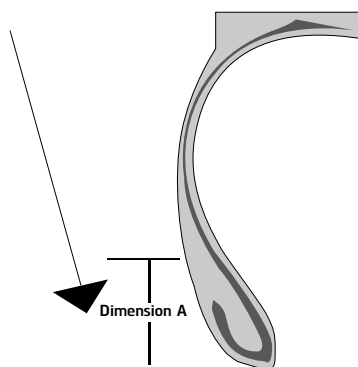

Dimension A = Non repairable area of radial tire

Tire Specification	Dimension A
Up to 7.50R/8R	2- 1/2"
15R22.5	2- 3/4"
8.25R, 9.00R, 10.00R	3"
9R, 10R, 11R	3"
16.5, 18R22.5	3"
285, 295, 305	
315/75R, 80R, 85R	3
11.00R, 12.00R	3- 1/2"
12R, 13R/FR20	3- 1/2"
12/80R, 13/80R, 14/80R	3- 1/2"

# Giti Truck Tire Usage Recommendations

## Fitting and Removal of Giti tires

This must be carried out by trained competent personnel using the correct equipment including lubricant. Incorrect fitting can result in damage to the tire (may not be visible at the time of fitting), tube or wheel. Tire fitment must be done following Giti instructions.

The inflation must be carried out in 2 stages:

- 1st Stage** .
- Pre-inflate to 1.5 bar, 22 psi
  - General inspection of the tire

The presence of blisters or deformations will necessitate the demounting of the tire to be examined by a tire specialist.

- 2nd Stage** .
- Inflate the tire to the required pressure
  - During inflation, the tire must be placed vertically in an inflation cage or a suitable secure area. The operator must position himself in line with the tread band during inflation

## Inflation pressure

Tires for commercial vehicles should be inflated to a pressure relevant to the load, speed, and condition of use. Suggested pressures are shown in the load/pressure tables. Using the correct pressure is essential to the safe running of the tire. Underinflation could result in the tires running at abnormally high temperatures leading to thermal degradation of the tires' components. This degradation is irreversible and can result in a rapid deflation of the tire.

The consequences of running underinflated are not necessarily immediately evident and may appear later after the underinflation has been corrected.

- Tire pressures must be checked on cold tires at least once a week or when the vehicle is serviced, using a calibrated pressure gauge
- The spare tire should also be checked
- Never "bleed" a tire when hot
- The valve cap is the primary air seal and must always be fitted

**(Note. The valve core acts as a one way valve to allow the tire to be inflated; it should not be treated as a seal)**

If your pressure check indicates one of your tires has lost pressure of 5 psi or more, look for signs of penetrations, valve leakage or wheel/rim damage which may account for the air loss. If the tire is 20% below the maintenance air pressure, it must be considered flat. Remove and inspect for punctures or other damage. If run flat damage is detected, scrap the tire.

## Wheels

- The state of all wheels should be regularly checked. Any cracked wheel or rim should be replaced.
- Wheels or rims should not be repaired by welding. If a welding operation has to be undertaken, the tire must be removed from the rim. If this is not done, there is a serious risk of explosion.
- The tire should only be refitted when all items have returned to ambient temperature.
- Before any welding on the vehicle chassis or at proximity of the tires, the tire and wheel assemblies should be removed from the vehicle.
- Before removing divided wheel assemblies from a vehicle, it is recommended that the tires are deflated.

# Giti Truck Tire Usage Recommendations

## Tire Care

Tires on a vehicle must be checked regularly, taking particular care to check:

- The tread, for signs of abnormal wear cuts, deformations and embedded foreign objects (stones, bolts, nails etc...)
- The sidewalls for cuts, impact damage (caused by pot-holes, riding curbs, etc...), rasping due to curbing, and abnormal deformations

Causes of vehicle handling problems such as, steering wheel vibrations, pulling to left or right, etc... should also be investigated

If loss of pressure occurs, it is imperative to stop as quickly as possible, as running underinflated causes thermal degradation of the tire components. The tire should be removed from the rim, and the reason for the loss of pressure determined

Any damage must be examined by a tire professional who is capable of determining if a repair is necessary or possible.

Repairs must be undertaken by a tire specialist, who will accept responsibility for the repair.

Before any repair, the interior of the tire must be examined to ensure that no degradation has occurred.

## Replacing Tires

- Replacement tires should be suitable for the conditions of use of the vehicle, and be capable of carrying the axle loads imposed
- Ensure that the tire fitment conforms to local legislation



**WARNING.** Reassembly and inflation of mismatched parts can result in serious injury or death. Just because parts fit together does not mean that they belong together. Check for proper matching of all rim parts before assembly. Mismatching tire and rim components is dangerous. A mismatched tire and rim assembly may explode and can result in serious injury or death. This warning applies to any combination of mismatched components and rim combinations. Never assemble a tire and rim unless you have positively identified and correctly matched the parts.



**WARNING.** Never inflate or re-inflate any tires that have been running underinflated or flat without careful inspection for damage, inside and out.



**WARNING.** Always demount the tire from the wheel and complete a thorough tire and wheel inspection prior to returning the components to service.

# Giti Truck Tire Usage Recommendations

## Twining of Tires

When tires are twinned, in order to avoid abnormal wear, and tire overloading problems, it is essential to ensure that twinned tires:

- Are of the same size, manufacturer, and tread pattern
- Operate at the same pressure
- Do not have a difference in tread depths of greater than 4 mm.

Valve extensions fitted to inner twins, permit easy verification of tire pressures.

It is essential to ensure that they are correctly fitted and supported with the appropriate brackets where necessary (see diagrams below).

## Truck tire valve extensions

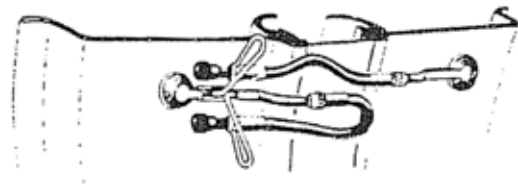
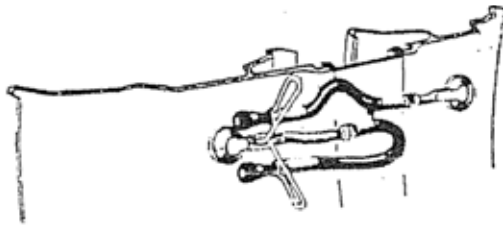

In these assemblies, always fit the valve facing each other.

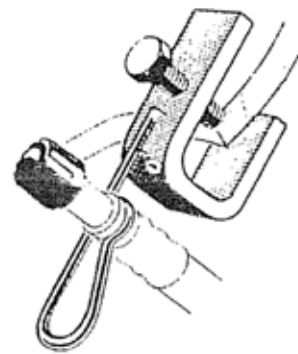
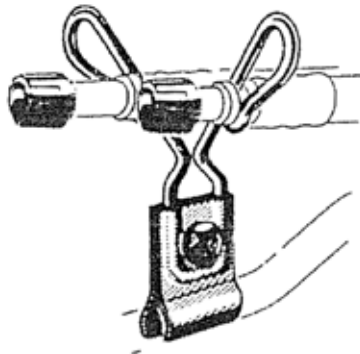

## Fixing clamps for Truck tire valve extensions

# Giti Truck Tire Usage Recommendations

## Retreading

Virtually all Giti truck tires are designed to be **RETREADED**.

*Giti tire products can be retreaded sometimes more than once.*

### What is tire retreading?

It refers to replacing the worn tread rubber.

By retread techniques, there are mainly two retreading methods:

1. Cold retreading refers to retreading with pre-cured tread, (eg. BANDAG method & Marangoni RTS method;)
2. Hot retreading uses uncured tread without pattern, also referred as conventional method.

### Giti reminders

- Since tire retreading can cut cost, please protect casing well
- If tire retreading is needed, please inquire with local supplier when left groove depth is 2-4 mm

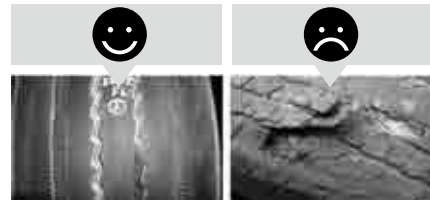

## Storage of Tires and Tubes

In order to avoid premature aging and degradation of tires, they should be stored in a dark and closed area.

If this is not possible, they should be protected from:

- Sources of ozone (sun, arc-welding, mercury vapor lamps...)
- Ultraviolet radiation
- Exposure to the weather

The tires should be stored vertically on their treads, one against the other.

Tubes, flaps and rubber seals should be stored in their original packaging. They may be stored on shelves or in containers, on condition that the surfaces in contact with them are clean and smooth (to avoid risk of tearing, cuts or perforations).



**WARNING.** In order to avoid premature aging and degradation of tires, they should be stored in a dark and closed area with the tires standing vertically on their treads, one against the other. If this is not possible, they should be protected from exposure to the weather, sources of ozone (sun, arc-welding, mercury vapor lamps...) and ultraviolet (UV) radiation.



## **Section 7**

# **How to identify a Better TRUCK Tire**



# Let's focus on 6 key areas.

1 Tread contact width



3 Under tread rubber depth



Bead construction

5

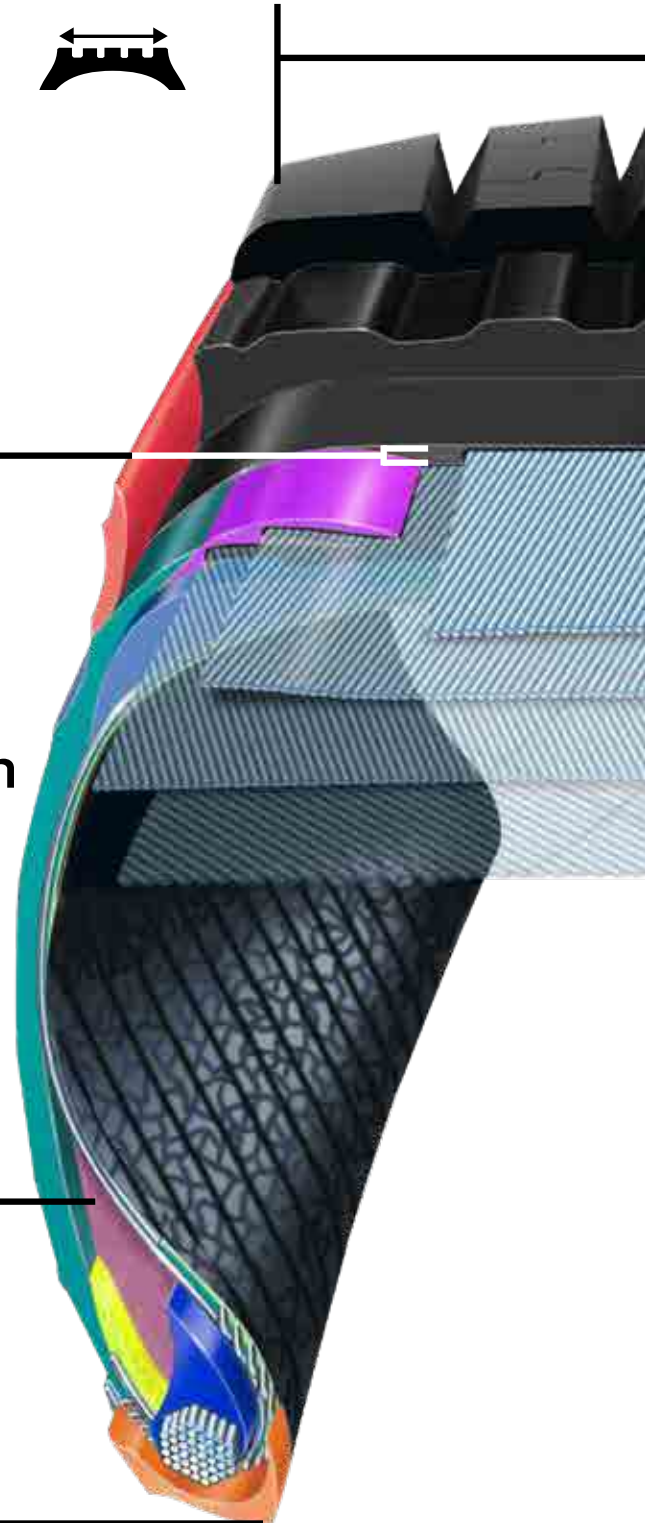

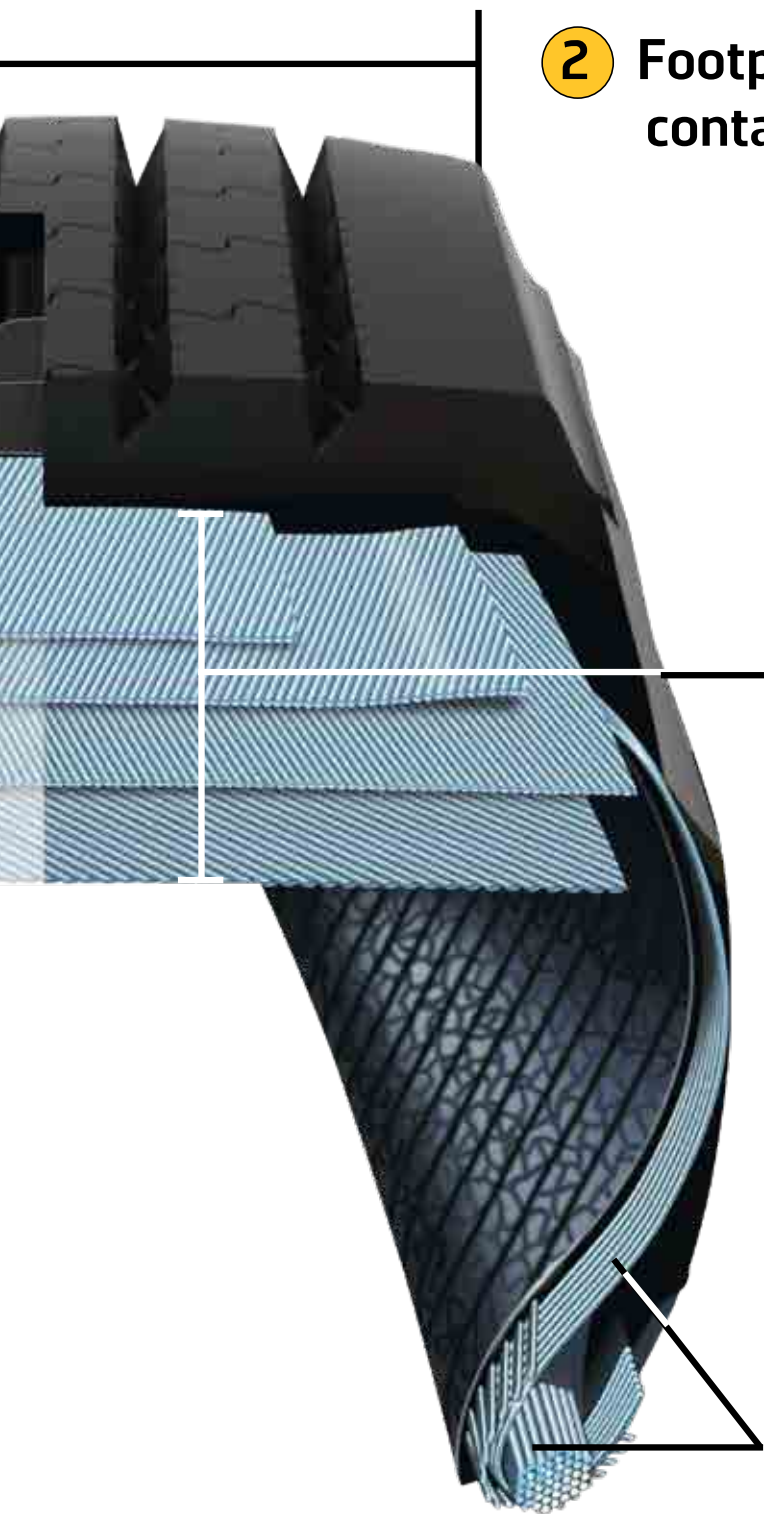

**2** Footprint and ground contact pressure area



**4** Belt layout



**6** Casing cords/  
Bead wire

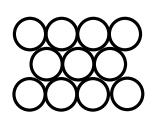



## The wider the tread is, the better it is. Why?

When the tread is wider, wearing volume and ground contact stability is increased. **This leads to better wear performance & higher mileage.**

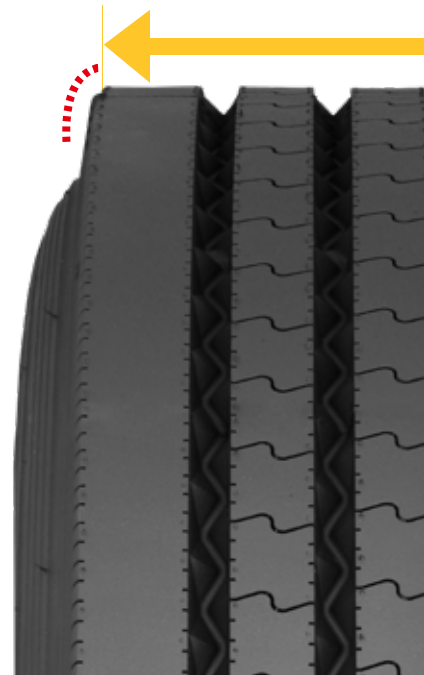

Tread Width- 238mm

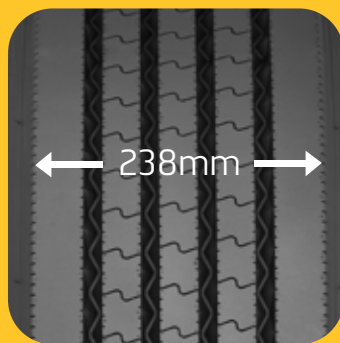

Size- 12R22.5

## Advantages-

- Wider tread design, with improved wear performance and mileage
- Less damage and improved durability





Budget tires have a more vulnerable area and narrower tread width

## Budget tire

Tread Width: 227mm



Size: 12R22.5

Tread of budget tire is **11mm narrower** than the Giti tire.

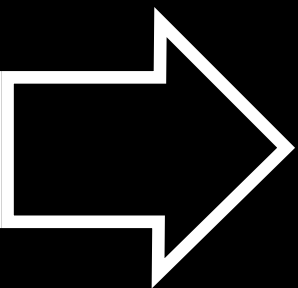

## Disadvantages:

- Less rubber and wear volume, less resistance to wear
  - Exposed vulnerable outer shoulder area
- Short tire life, frequent tire change demanded

The closer to rectangular shape the contact area is, the more durable the tire is.

If the contact area is close to an oval shape:  
**The wear life is compromised due to different rolling circumferences across the tread width**

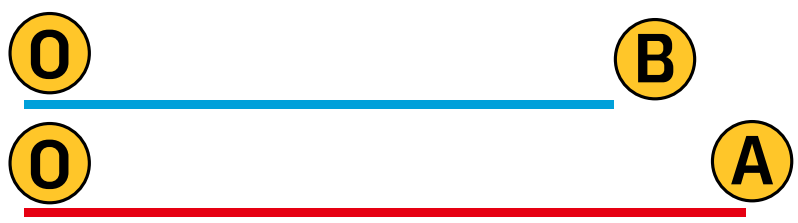

Rectangular rate **91.7%**

The contact area of Giti is **more rectangular** than that of the budget tire

### Advantages.

- High resistance to wear. High mileage.
- Reduced irregular wear

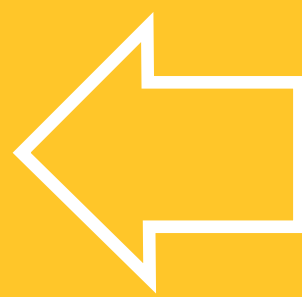

## While driving.

The rolling circumference of the tread center is longer than that of the tread edge, leading to more wear along the tread edges, potentially inducing irregular wear.

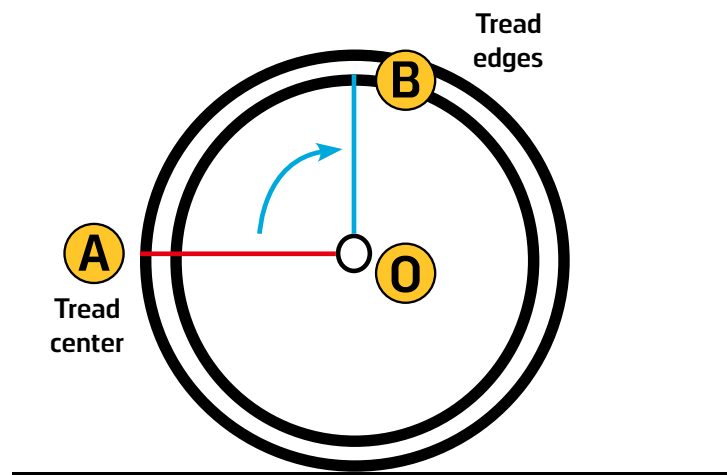

## Budget tire

Rectangular rate **78.4%**



## Disadvantages:

- Not resistant to wear. Wears out quickly.
- Shorter tire life. Frequent tire change demanded

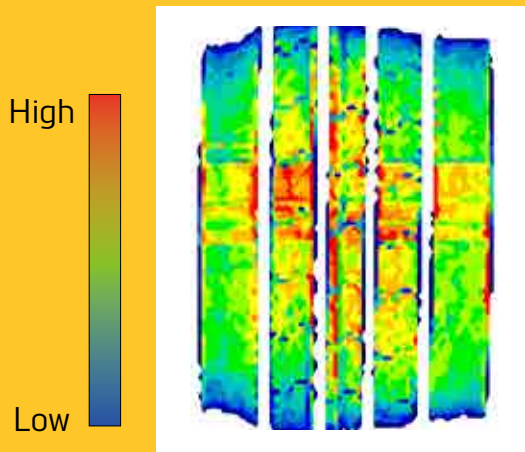

Contact pressure is distributed evenly.

Giti tire contact pressure is more even than that of the budget tire

## Advantages.

- Even distribution of contact pressure.
- High resistance to wear. High mileage.



Depth **5mm.**

Under-tread rubber depth is deeper than most budget tires

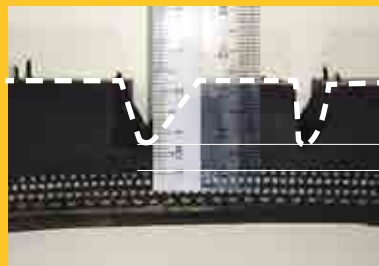

5mm

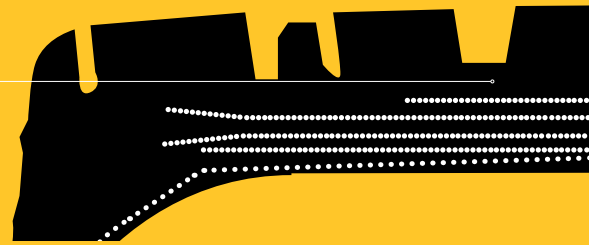

## Advantages.

- Thick under-tread rubber. Long tire life.
  - Safe when tread is worn out.
- The tire can be retreaded & regrooved, reducing cost.





Budget tire  
Contact pressure  
concentrated in  
center area.

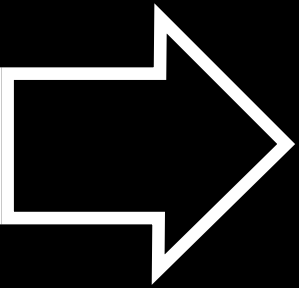
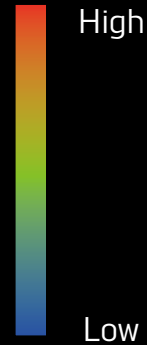
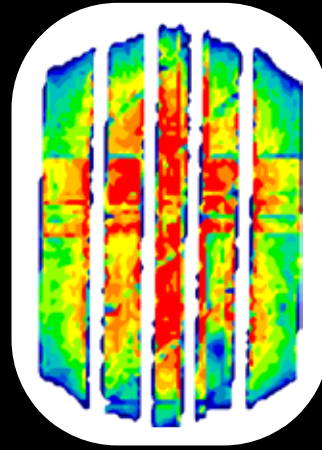

## Disadvantages:

- Easy for irregular and fast wear.
- Impact to car owners: Short tire life, frequent tire change needed

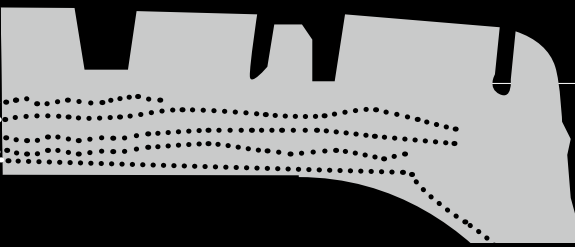

Budget tire  
Depth **3.5mm**

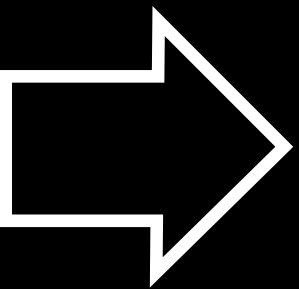

## Disadvantages:

- Easier for groove cracking or belt cuts
- Short tire life, poor durability

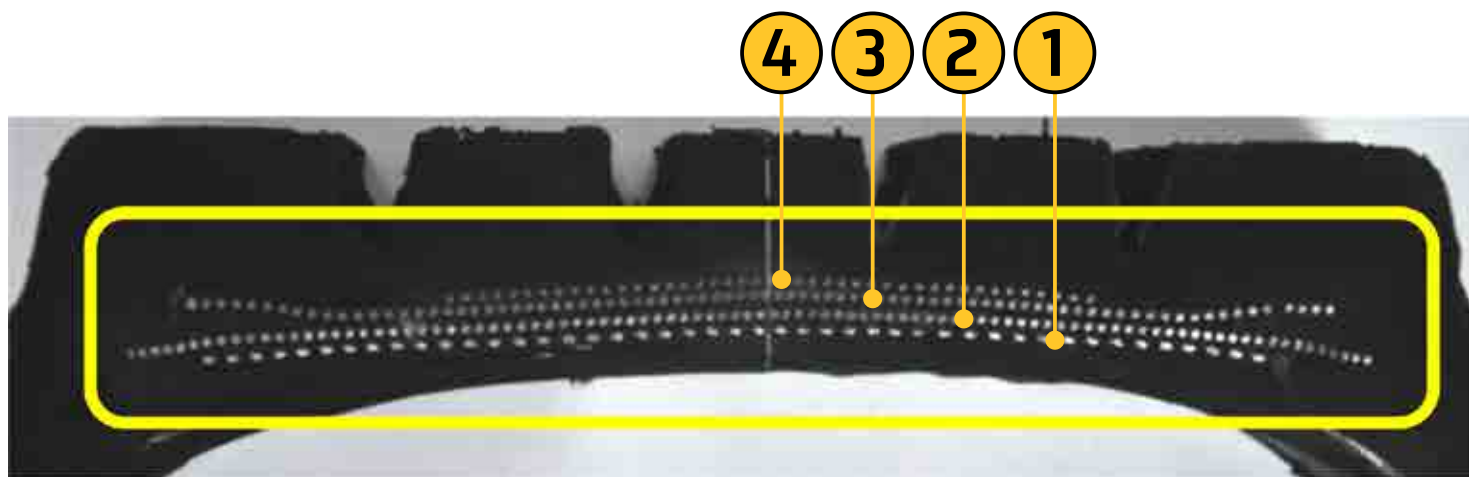

## What is a 4-belt design and how does it benefit vehicle owners?



### Advantages.

- Consistent belt package
- Giti Tire with 4-belt design optimizes tread rigidity.
  - Improves contact pressure and wear performance.
- Contact area close to rectangle offering better wear performance

# Understand 4-Belt Construction

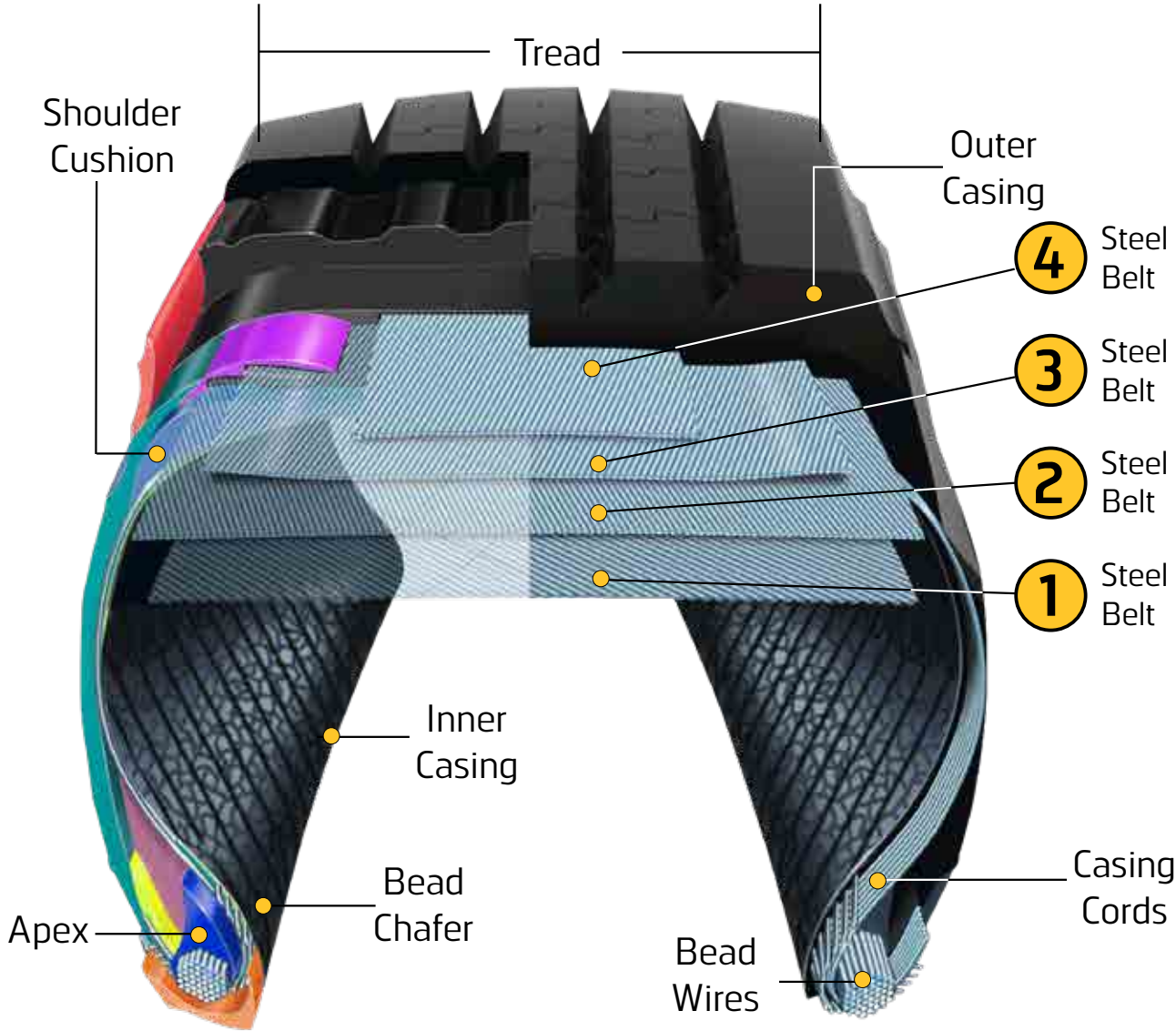



## Uniform belt layout due to advanced production techniques

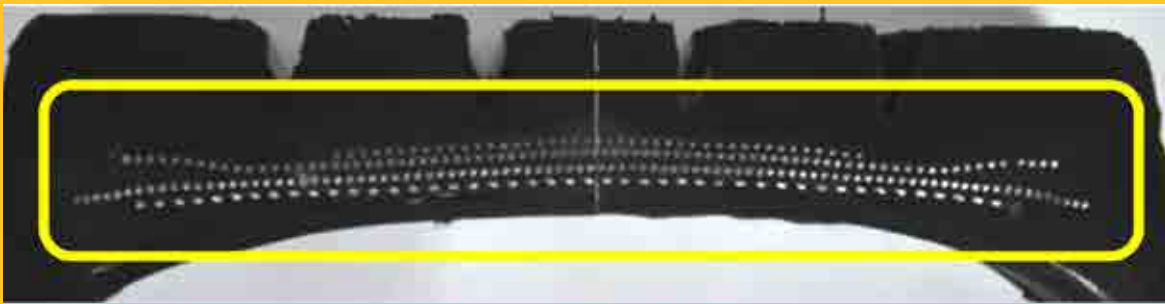

### Advantages.

- Better techniques for belt engineering. Higher mileage.
- Fuel saving and positive environmental impact.



## Belt cords arrangement are parallel



### Advantages.

- Parallel cords will minimize and/or even stop contamination when rust & water penetrates through damage area, making tires safer
- Preserve tire integrity which will increase retreadability

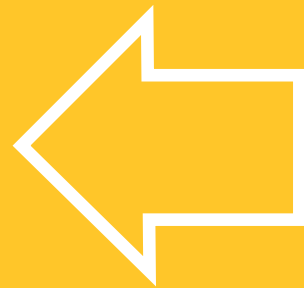

## Budget tire

Belts warp due to poor construction, production techniques, and lack of consistency



**Disadvantages:** • Poor bonding performance.

- Easy deformation and wear. High rolling resistance.
- Shorter life with high fuel consumption.

Budget tire

Belt cords are not parallel

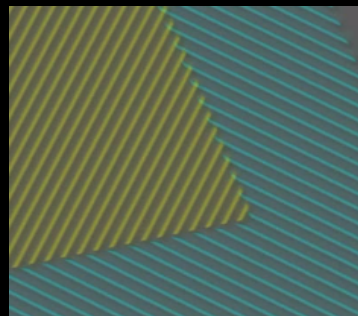

**Disadvantages:**

- When water penetrates from Belt 4 to Belt 3 through damaged area, the water flow on Belt 3 will spread toward its cord direction, which is crossing cords of Belt 4. The rust area is large and cords are vulnerable, leading to tread separation
- Low casing acceptance rate for retread

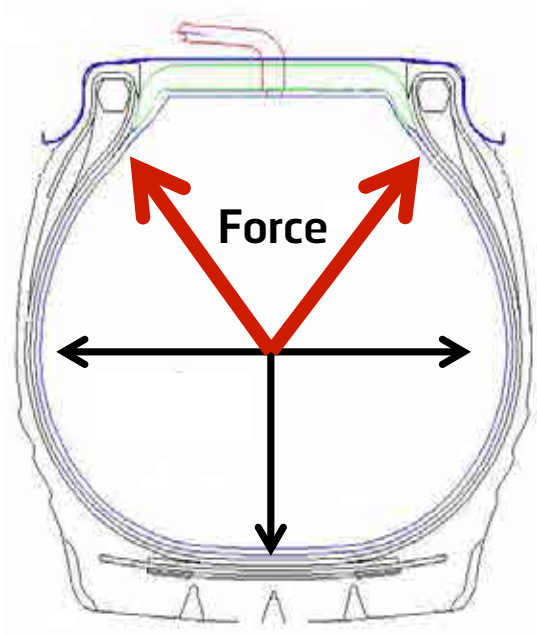

As a force and contact bearing point, bead acts as support to pass force from tire to rim.

Bead contact area with rim edge has 10 times pressure on the interface compared to other parts of tire.

**Demand on bead- High strength, Heat dissipation**



### Thick rubber cushion

Cushion rubber of the Giti bead is stronger than that of the budget tire



### Advantages-

- Advanced bead engineering
  - Good load performance
  - Safer to Drive
  - Cool running



Most of the Giti product have the DUO FILLER technology for excellent durability

 **DUO FILLER** is the combination of two bead fillers: Hard and Soft

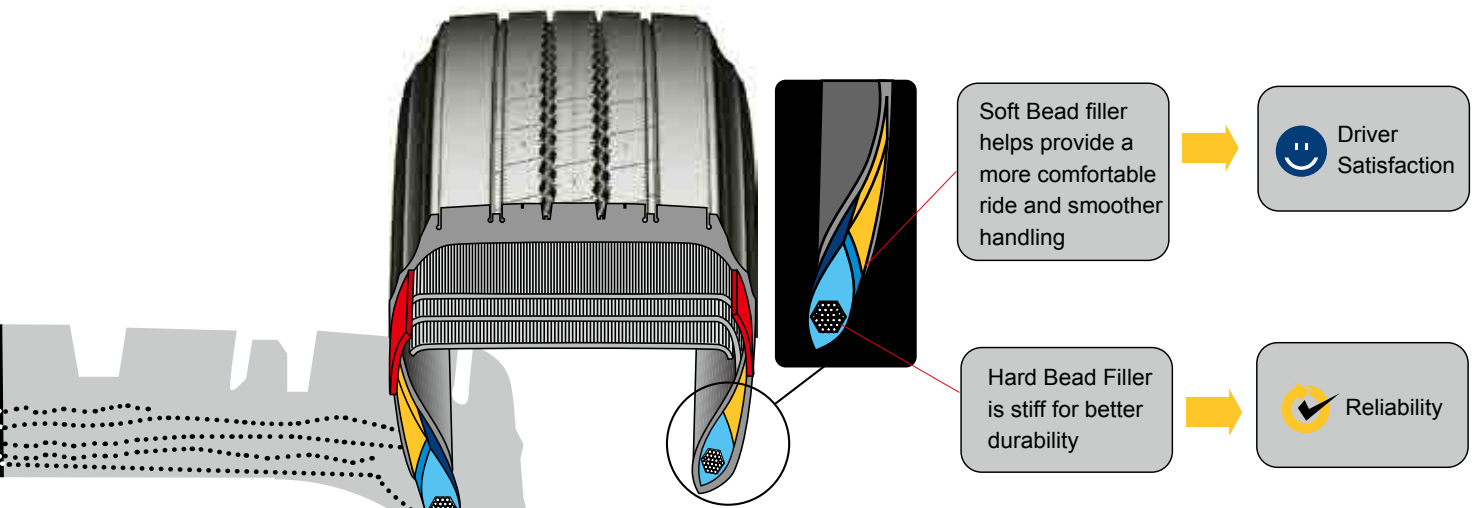

Budget tire  
Thin rubber cushion



Disadvantages:

- Low casing strength.
- Easy for the tire to burst and damage
- Poor load capacity and durability



Diameter about **1.140mm**

**High density and tight**

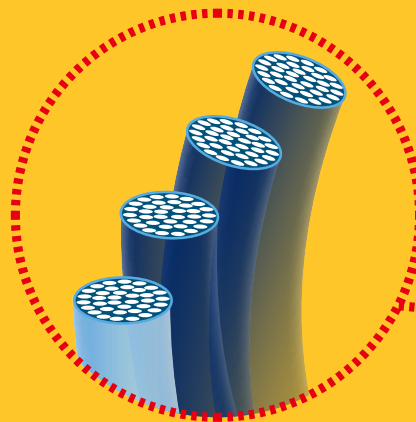

## Advantages-

- Bigger & Stronger casing cords, with better load capacity
  - Safer and more durable
  - High casing cords density
  - Increased retreadability





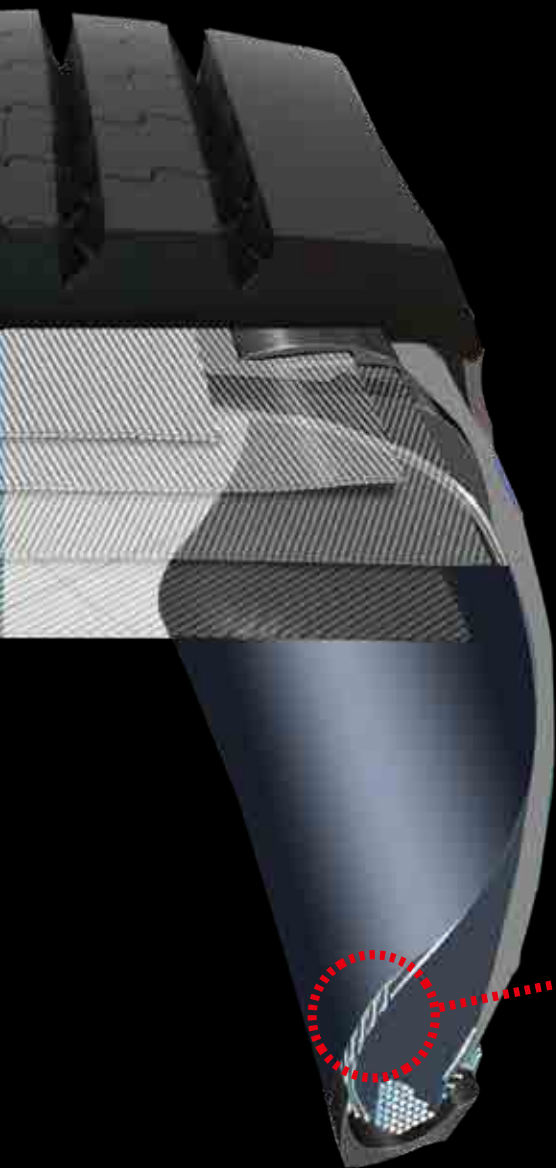

## Budget tire

Diameter about **0.940mm**

Low density and uneven cords

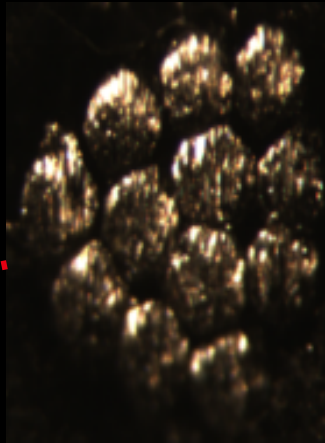

Casing cords of budget tire are **0.2mm thinner** than the Giti tire

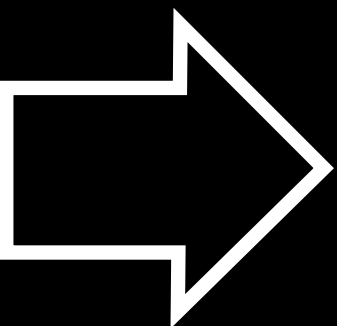

## Disadvantages:

- Low casing strength and load capacity
- More casing fatigue for less retreadability
  - Poor durability



**72** steel cords



**Tidy cords, fine techniques**

## **Advantages-**

- More bead cords. Fine bead techniques
- Good load performance. Safer to Drive
- Stronger construction



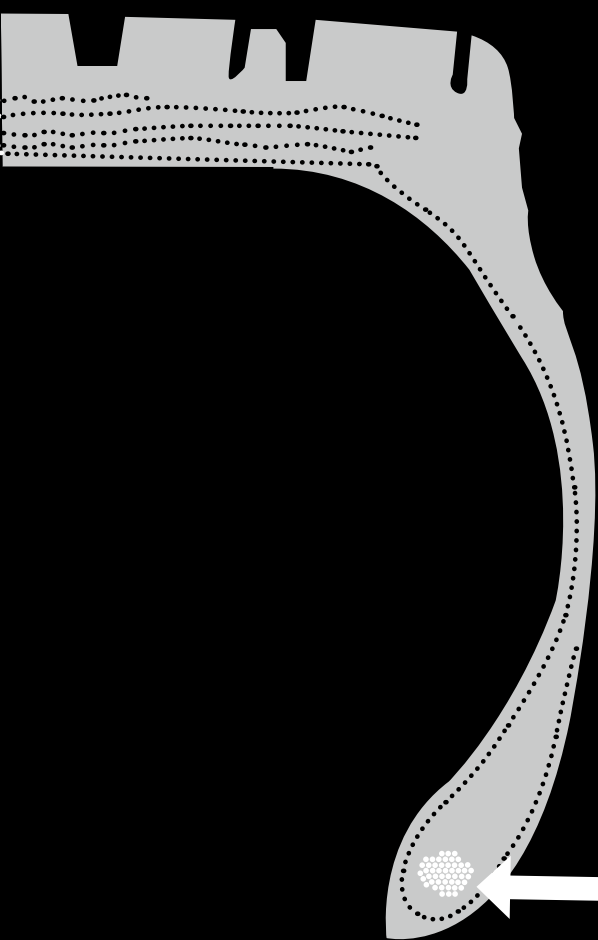

## Budget tire

65 steel cords



Budget tire cords are **7** less than that of the Giti tire

Bead cords loosened, poor techniques

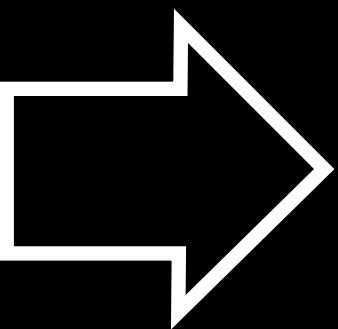

## Disadvantages:



























- Low casing strength and poor load performance.
- Easy for tire burst.
- Poor durability

# TECHNOLOGIES







Equal Force Casing



Features	 Best Price per Kilometer	 Driver Satisfaction	 Reliability	Application
EFC is Giti tire's specially designed casing technology enabling an optimal tire footprint and equal force distribution resulting in both better control and regular tread wear	*	*	*	   
Duo Filler is the combination of two different bead fillers: Hard and Soft to produce both comfort and robustness.	*	*	*	   
Sidewall Protector Ribs protect the casing from curbing & sidewall damage	*		*	   
Cap & Base Tread Design Cap layer provides wear resistant qualities and base insulates the casing against heat for cooler running.	*		*	   
Stone Ejector prevents stone penetration inside the belt.	*	*	*	   
Ex-Depth Solid Shoulder increased volume on the shoulder area resulting in more even wear especially on long haul applications.	*	*		 
Ex-Depth Open Shoulder allows greater traction and improved resistance to heel and toe wear.	*	*		 







## TECHNICAL SPECIFICATIONS

Bead	Series	Size	Pattern	Index	Index 2	PR	M+S	Type		Approved Rims Width					Original Tread Depth (OTD)	Min. Dual Spacing		
									Recommended Rim (Inches)		Section Width (mm)	Overall Diameter (mm)	Static Laden Radius (mm)	Rolling Circumference (mm)				
16	100	6.50R16	GAR859	110/105L		12PR		TT	5.50F	5.00E;5.00F	185	750	349	2273	11.0	213		
		7.00R16	GAL816+	118/114M		14PR		TL/TT	5.50F	6.00G;5?K	200	775	360	2348	11.0	230		
			GAO829	118/114F		14PR		TT	5.50F	6.00G	200	775	360	2348	15.5	230		
		7.50R16	GAR859	118/114L		14PR		TL/TT	5.50F	6.00G;5?K	200	775	360	2348	11	230		
			GAL816+	122/118M		14PR		TL/TT	6.00G	5.50F;6.50H;6K	215	805	373	2439	12.0	247		
			GAR859	122/118L		14PR	M+S	TT	6.00G	5.50F;6.50H	215	805	373	2439	14.5	247		
		8.25R16	GAO829	122/118F		14PR		TT	6.00G	5.50F;6.50H	215	805	373	2439	16	247		
			GAL816+	128/124M		16PR		TT	6.50H	6.00G;6.5	235	855	394	2591	12.5	270		
			GAO829	128/124F		16PR		TT	6.50H	6.00G;6.5	235	855	394	2591	16.8	270		
				9.5R17.5	GAR859	128/124M		16PR	M+S	TT	6.50H	6.00G;6.5	235	855	394	2591	14.5	270
					GAR820	143/141K		16PR	M+S	TL	6.75	6	240	842	391	2568	12.5	270
					GDR638	143/141K		18PR	M+S	TL	6.75	6	240	842	391	2568	12.5	270
17.5	75	225/80R17.5	GAR850	123/122L		14PR	M+S	TL	6.75	6	226	805	375	2455	13.5	254		
			GAR820	124/122M		14PR	M+S	TL	6	5.25;6.75	204	753	353	2297	12.5	230		
		205/75R17.5	GDR638	124/122M		14PR	M+S	TL	6	5.25;6.75	204	753	353	2297	14.0	230		
			GTL919	136/134J		16PR	M+S	TL	6	6.75	211	767	359	2339	12.5	237		
		215/75R17.5	GAR820	128/126M		14PR	M+S	TL	6	6.75	211	767	359	2339	13.0	237		
			GAU867V1	128/126M		14PR	M+S	TL	6	6.75	211	767	359	2339	13.5	237		
			GDR638	126/124M		14PR	M+S	TL	6	6.75	211	767	359	2339	14.5	237		
		225/75R17.5	GAR820	129/127M		14PR	M+S	TL	6.75	6	226	783	366	2388	13.0	254		
			GDR638	129/127M		14PR	M+S	TL	6.75	6	226	783	366	2388	15.0	254		
		235/75R17.5	GTL919	143/141J	146/146F	16PR	M+S	TL	6.75	7.5	233	797	372	2431	13.0	262		
			GAR820	132/130M		14PR	M+S	TL	6.75	7.5	233	797	372	2431	13.5	262		
			GDR638	132/130M		14PR	M+S	TL	6.75	7.5	233	797	372	2431	15.0	262		
245/70R17.5	GTL919	143/141J	146/146F	16PR	M+S	TL	7.5	6.75	248	789	364	2406	13.0	279				
	GAR820	136/134M		14PR	M+S	TL	7.5	6.75	248	789	364	2406	13.5	279				
	GDR638	136/134M		14PR	M+S	TL	7.5	6.75	248	789	364	2406	14.5	279				

## LOAD CAPACITY by AXLE (kg) and PRESSURE (psi/bar)

	Load		Index	S= Single D= Dual	65.25	68.88	72.50	76.13	79.75	83.38	87.00	90.63	94.25	97.88	101.50	105.13	108.75	112.38	116.00	119.63	123.25	126.88	130.50	134.13	137.75
	Single (kg)	Dual (kg)			4.50	4.75	5.00	5.25	5.50	5.75	6.00	6.25	6.50	6.75	7.00	7.25	7.50	7.75	8.00	8.25	8.50	8.75	9.00	9.25	9.50
1060	925	110	S	1560	1630	1700	1770	1840	1910	1980	2050	2120													
		105	D	2750	2870	2990	3110	3230	3350	3470	3590	3700													
1320	1180	118	S	1750	1830	1910	1990	2070	2150	2220	2290	2360	2430	2500	2570	2640									
		114	D	3130	3270	3410	3550	3680	3810	3940	4070	4200	4330	4460	4590	4720									
1320	1180	118	S	1750	1830	1910	1990	2070	2150	2220	2290	2360	2430	2500	2570	2640									
		114	D	3130	3270	3410	3550	3680	3810	3940	4070	4200	4330	4460	4590	4720									
1320	1180	118	S	1750	1830	1910	1990	2070	2150	2220	2290	2360	2430	2500	2570	2640									
		114	D	3130	3270	3410	3550	3680	3810	3940	4070	4200	4330	4460	4590	4720									
1500	1320	122	S	1990	2080	2170	2260	2350	2440	2520	2600	2680	2760	2840	2920	3000									
		118	D	3510	3670	3820	3970	4120	4270	4420	4570	4720	4860	5000	5140	5280									
1500	1320	122	S	1990	2080	2170	2260	2350	2440	2520	2600	2680	2760	2840	2920	3000									
		118	D	3510	3670	3820	3970	4120	4270	4420	4570	4720	4860	5000	5140	5280									
1500	1320	122	S	1990	2080	2170	2260	2350	2440	2520	2600	2680	2760	2840	2920	3000									
		118	D	3510	3670	3820	3970	4120	4270	4420	4570	4720	4860	5000	5140	5280									
1800	1600	128	S	2390	2500	2600	2700	2800	2900	3000	3100	3200	3300	3400	3500	3600									
		124	D	4250	4440	4630	4810	4990	5170	5350	5530	5710	5890	6060	6230	6400									
1800	1600	128	S	2390	2500	2600	2700	2800	2900	3000	3100	3200	3300	3400	3500	3600									
		124	D	4250	4440	4630	4810	4990	5170	5350	5530	5710	5890	6060	6230	6400									
1800	1600	128	S	2390	2500	2600	2700	2800	2900	3000	3100	3200	3300	3400	3500	3600									
		124	D	4250	4440	4630	4810	4990	5170	5350	5530	5710	5890	6060	6230	6400									
2725	2575	143	S	3200	3340	3480	3620	3760	3900	4030	4160	4290	4420	4550	4680	4810	4940	5070	5200	5330	5450				
		141	D	6050	6320	6580	6840	7100	7360	7610	7860	8110	8360	8610	8860	9100	9340	9580	9820	10060	10300				
2725	2575	143	S	3200	3340	3480	3620	3760	3900	4030	4160	4290	4420	4550	4680	4810	4940	5070	5200	5330	5450				
		141	D	6050	6320	6580	6840	7100	7360	7610	7860	8110	8360	8610	8860	9100	9340	9580	9820	10060	10300				
1550	1500	123	S	2180	2280	2380	2470	2560	2650	2740	2830	2920	3010	3100											
		122	D	4220	4410	4590	4770	4950	5130	5310	5490	5660	5830	6000											
1600	1500	124	S	2120	2210	2300	2390	2480	2570	2660	2750	2840	2930	3020	3110	3200									
		122	D	3990	4170	4340	4510	4680	4850	5020	5190	5360	5520	5680	5840	6000									
1600	1500	124	S	2120	2210	2300	2390	2480	2570	2660	2750	2840	2930	3020	3110	3200									
		122	D	3990	4170	4340	4510	4680	4850	5020	5190	5360	5520	5680	5840	6000									
2240	2120	136	S	2580	2690	2800	2910	3020	3130	3240	3350	3460	3570	3680	3780	3880	3980	4080	4180	4280	4380	4480			
		134	D	4870	5090	5300	5510	5720	5930	6140	6340	6540	6740	6940	7140	7340	7530	7720	7910	8100	8290	8480			
1800	1700	128	S	2520	2630	2740	2850	2960	3070	3180	3290	3400	3500	3600											
		126	D	4780	4990	5200	5410	5610	5810	6010	6210	6410	6610	6800											
1800	1700	128	S	2390	2500	2600	2700	2800	2900	3000	3100	3200	3300	3400	3500	3600									
		126	D	4520	4720	4920	5120	5310	5500	5690	5880	6070	6260	6440	6620	6800									
1700	1600	126	S	2390	2500	2600	2700	2800	2900	3000	3100	3200	3300	3400											
		124	D	4500	4700	4900	5090	5280	5470	5660	5850	6040	6220	6400											
1850	1750	129	S	2520	2630	2740	2850	2960	3070	3180	3290	3400	3500	3600	3700										
		127	D	4780	4990	5200	5410	5610	5810	6010	6210	6410	6610	6810	7000										
1850	1750	129	S	2520	2630	2740	2850	2960	3070	3180	3290	3400	3500	3600	3700										
		127	D	4780	4990	5200	5410	5610	5810	6010	6210	6410	6610	6810	7000										
2725	2575	143	S	3280	3420	3560	3700	3840	3980	4120	4260	4400	4540	4670	4800	4930	5060	5190	5320	5450					
		141	D	6200	6470	6740	7010	7280	7540	7800	8060	8320	8570	8820	9070	9320	9570	9820	10060	10300					
2000	1900	132	S	2650	2770	2890	3010	3120	3230	3340	3450	3560	3670	3780	3890	4000									
		130	D	5060	5280	5500	5720	5940	6150	6360	6570	6780	6990	7200	7400	7600									
2000	1900	132	S	2460	2570	2680	2790	2900	3000	3100	3200	3300	3400	3500	3600	3700	3800	3900	4000						
		130	D	4680	4890	5090	5290	5490	5690	5890	6090	6280	6470	6660	6850	7040	7230	7420	7600						
2725	2575	143	S	3200	3340	3480	3620	3760	3900	4030	4160	4290	4420	4550	4680	4810	4940	5070	5200	5330	5450				
		141	D	6050	6320	6580	6840	7100	7360	7610	7860	8110	8360	8610	8860	9100	9340	9580	9820	10060	10300				
2240	2120	136	S	2680	2800	2920	3040	3160	3270	3380	3490	3600	3710	3820	3930	4040	4150	4260	4370	4480					
		134	D	5100	5330	5550	5770	5990	6210	6420	6630	6840	7050	7260	7470	7680	7880	8080	8280	8480					
2240	2120	136	S	2680	2800	2920	3040	3160	3270	3380	3490	3600	3710	3820	3930	4040	4150	4260	4370	4480					
		134	D	5100	5330	5550	5770	5990	6210	6420	6630	6840	7050	7260	7470	7680	7880	8080	8280	8480					

## TECHNICAL SPECIFICATIONS

Bead	Series	Size	Pattern	Index	Index 2	PR	M+S	Type	 Giti Recommended Rim (Inches)	Approved Rims Width	 Section Width (mm)	 Overall Diameter (mm)	 Static Laden Radius (mm)	 Rolling Circumference (mm)	Original Tread Depth (OTD)	Min. Dual Spacing	
19.5	70	225/70R19.5	GDR638	128/126L		14PR	M+S	TL	6.75	6	226	817	380	2492	14.3	254	
			GSR225	128/126L		14PR	M+S	TL	6.75	6	226	811	378	2474	13	254	
		245/70R19.5	GTL919	141/140J		18PR	M+S	TL	7.50	6.75	248	839	389	2559	14.0	279	
			GDR638	136/134M		16PR	M+S	TL	7.50	6.75	248	839	389	2559	16.0	279	
			GAR850	136/134J		16PR	M+S	TL	7.50	6.75	248	839	389	2559	14.0	279	
			GSR225	136/134M		16PR	M+S	TL	7.50	6.75	248	839	389	2559	14.0	279	
			GT867	136/134M		16PR	M+S	TL	7.5	6.75	248	839	389	2559	15.8	279	
		265/70R19.5	GAU867V1	143/141J		18PR	M+S	TL	7.5	8.25	262	867	401	2644	15.5	295	
			GTL919	143/141J		18PR	M+S	TL	7.5	8.25	262	867	401	2644	14.5	295	
			GTR923	143/141J		18PR	M+S	TL	7.5	8.25	262	867	401	2644	14.5	295	
	GDR638		140/138M		16PR	M+S	TL	7.5	6.75	262	867	401	2644	16.5	295		
	GSR225		140/138M		16PR	M+S	TL	7.5	8.25	262	867	401	2644	14	295		
	285/70R19.5	GTL919	150/148J		18PR	M+S	TL	8.25	9	283	895	413	2730	14	318		
		GDR638	146/145M		16PR	M+S	TL	8.25	9	283	895	413	2730	17	318		
		GSR225	146/145M		16PR	M+S	TL	8.25	9	283	895	413	2730	14.5	318		
	50	45	435/50R19.5	GTL925	164J		20PR	M+S	TL	14	15	438	931	431	2821	12.9	493
			445/45R19.5	GTL925	164J		22PR	M+S	TL	14	15	436	895	416	2712	12.9	491
	20	100	7.50R20	GAL817	130/128K		14PR		TT	6	6.5;6.00T; 6.50T	215	935	435	2833	13.0	247
			8.25R20	GAR558	139/137K		16PR		TT	6.5	7.0;6.50T; 7.00T	236	974	452	2951	14.0	271
				GAM839	139/137K		16PR		TT	6.5	7.0;6.50T; 7.00T	236	974	452	2951	14.5	271
GDM680				139/137K		16PR		TT	6.5	7.0;6.50T; 7.00T	236	974	452	2951	15.8	271	
GAO822				139/137F		16PR		TT	6.5	7.0;6.50T; 7.00T	236	986	457	2988	18.7	271	
GAO829				139/137F		16PR		TT	6.5	7.0;6.50T; 7.00T	236	986	457	2988	19.0	271	
GAL817				136/134K		14PR		TT	6.5	7.0;6.50T; 7.00T;7.0T5°	236	974	452	2951	14.0	271	



**LOAD CAPACITY by AXLE (kg) and PRESSURE (psi/bar)**

	Load		Index	S= Single D= Dual	65.25	68.88	72.50	76.13	79.75	83.38	87.00	90.63	94.25	97.88	101.50	105.13	108.75	112.38	116.00	119.63	123.25	126.88	130.50	134.13	137.75	
	Single (kg)	Dual (kg)			4.50	4.75	5.00	5.25	5.50	5.75	6.00	6.25	6.50	6.75	7.00	7.25	7.50	7.75	8.00	8.25	8.50	8.75	9.00	9.25	9.50	
1800	1700	128	S	2390	2500	2600	2700	2800	2900	3000	3100	3200	3300	3400	3500	3600										
		126	D	4520	4720	4920	5120	5310	5500	5690	5880	6070	6260	6440	6620	6800										
1800	1700	128	S	2390	2500	2600	2700	2800	2900	3000	3100	3200	3300	3400	3500	3600										
		126	D	4520	4720	4920	5120	5310	5500	5690	5880	6070	6260	6440	6620	6800										
2575	2500	141	S	3100	3240	3380	3510	3640	3770	3900	4030	4160	4290	4420	4550	4670	4790	4910	5030	5150						
		140	D	6000	6270	6530	6790	7050	7310	7560	7810	8060	8310	8560	8800	9040	9280	9520	9760	10000						
2240	2120	136	S	2760	2880	3000	3120	3240	3360	3480	3600	3710	3820	3930	4040	4150	4260	4370	4480							
		134	D	5220	5450	5680	5910	6130	6350	6570	6790	7010	7220	7430	7640	7850	8060	8270	8480							
2240	2120	136	S	2680	2800	2920	3040	3160	3270	3380	3490	3600	3710	3820	3930	4040	4150	4260	4370	4480						
		134	D	5100	5330	5550	5770	5990	6210	6420	6630	6840	7050	7260	7470	7680	7880	8080	8280	8480						
2240	2120	136	S	2760	2880	3000	3120	3240	3360	3480	3600	3710	3820	3930	4040	4150	4260	4370	4480							
		134	D	5220	5450	5680	5910	6130	6350	6570	6790	7010	7220	7430	7640	7850	8060	8270	8480							
2240	2120	136	S	2760	2880	3000	3120	3240	3360	3480	3600	3710	3820	3930	4040	4150	4260	4370	4480							
		134	D	5220	5450	5680	5910	6130	6350	6570	6790	7010	7220	7430	7640	7850	8060	8270	8480							
2725	2575	143	S	3280	3420	3560	3700	3840	3980	4120	4260	4400	4540	4670	4800	4930	5060	5190	5320	5450						
		141	D	6200	6470	6740	7010	7280	7540	7800	8060	8320	8570	8820	9070	9320	9570	9820	10060	10300						
2725	2575	143	S	3280	3420	3560	3700	3840	3980	4120	4260	4400	4540	4670	4800	4930	5060	5190	5320	5450						
		141	D	6200	6470	6740	7010	7280	7540	7800	8060	8320	8570	8820	9070	9320	9570	9820	10060	10300						
2725	2575	143	S	3280	3420	3560	3700	3840	3980	4120	4260	4400	4540	4670	4800	4930	5060	5190	5320	5450						
		141	D	6200	6470	6740	7010	7280	7540	7800	8060	8320	8570	8820	9070	9320	9570	9820	10060	10300						
2500	2360	140	S	3240	3380	3520	3660	3800	3940	4080	4220	4350	4480	4610	4740	4870	5000									
		138	D	6110	6380	6650	6910	7170	7430	7690	7950	8200	8450	8700	8950	9200	9440									
2500	2360	140	S	3240	3380	3520	3660	3800	3940	4080	4220	4350	4480	4610	4740	4870	5000									
		138	D	6110	6380	6650	6910	7170	7430	7690	7950	8200	8450	8700	8950	9200	9440									
3350	3150	150	S	3840	4010	4180	4350	4520	4680	4840	5000	5160	5320	5480	5640	5800	5950	6100	6250	6400	6550	6700				
		148	D	7240	7560	7880	8190	8500	8810	9110	9410	9710	10010	10310	10600	10890	11180	11470	11760	12040	12320	12600				
3000	2900	146	S	3440	3590	3740	3890	4040	4190	4340	4480	4620	4760	4900	5040	5180	5320	5460	5600	5740	5870	6000				
		145	D	6670	6960	7250	7540	7830	8110	8390	8670	8950	9220	9490	9760	10030	10300	10560	10820	11080	11340	11600				
3000	2900	146	S	3440	3590	3740	3890	4040	4190	4340	4480	4620	4760	4900	5040	5180	5320	5460	5600	5740	5870	6000				
		145	D	6670	6960	7250	7540	7830	8110	8390	8670	8950	9220	9490	9760	10030	10300	10560	10820	11080	11340	11600				
5000	-	164	S	5750	6000	6250	6500	6750	6990	7230	7470	7710	7950	8180	8410	8640	8870	9100	9330	9560	9780	10000				
5000	-	164	S	5750	6000	6250	6500	6750	6990	7230	7470	7710	7950	8180	8410	8640	8870	9100	9330	9560	9780	10000				
1900	1800	130	S	2340	2440	2540	2640	2740	2840	2940	3040	3140	3240	3340	3440	3530	3620	3710	3800							
		128	D	4420	4620	4810	5000	5190	5380	5570	5760	5940	6120	6300	6480	6660	6840	7020	7200							
2430	2300	139	S	2720	2840	2960	3080	3200	3320	3430	3540	3650	3760	3870	3980	4090	4200	4310	4420	4530	4640	4750	4860			
		137	D	5170	5400	5630	5850	6070	6290	6510	6730	6940	7150	7360	7570	7780	7990	8200	8400	8600	8800	9000	9200			
2430	2300	139	S	2720	2840	2960	3080	3200	3320	3430	3540	3650	3760	3870	3980	4090	4200	4310	4420	4530	4640	4750	4860			
		137	D	5170	5400	5630	5850	6070	6290	6510	6730	6940	7150	7360	7570	7780	7990	8200	8400	8600	8800	9000	9200			
2430	2300	139	S	2720	2840	2960	3080	3200	3320	3430	3540	3650	3760	3870	3980	4090	4200	4310	4420	4530	4640	4750	4860			
		137	D	5170	5400	5630	5850	6070	6290	6510	6730	6940	7150	7360	7570	7780	7990	8200	8400	8600	8800	9000	9200			
2430	2300	139	S	2720	2840	2960	3080	3200	3320	3430	3540	3650	3760	3870	3980	4090	4200	4310	4420	4530	4640	4750	4860			
		137	D	5170	5400	5630	5850	6070	6290	6510	6730	6940	7150	7360	7570	7780	7990	8200	8400	8600	8800	9000	9200			
2430	2300	139	S	2720	2840	2960	3080	3200	3320	3430	3540	3650	3760	3870	3980	4090	4200	4310	4420	4530	4640	4750	4860			
		137	D	5170	5400	5630	5850	6070	6290	6510	6730	6940	7150	7360	7570	7780	7990	8200	8400	8600	8800	9000	9200			
2240	2120	136	S	2760	2880	3000	3120	3240	3360	3480	3600	3710	3820	3930	4040	4150	4260	4370	4480							
		134	D	5220	5450	5680	5910	6130	6350	6570	6790	7010	7220	7430	7640	7850	8060	8270	8480							





## TECHNICAL SPECIFICATIONS

Bead	Series	Size	Pattern	Index	Index 2	PR	M+S	Type	 Giti Recommended Rim (Inches)	Approved Rims Width	 Section Width (mm)	 Overall Diameter (mm)	 Static Laden Radius (mm)	 Rolling Circumference (mm)	Original Tread Depth (OTD)	Min. Dual Spacing
20	100	9.00R20	GAR558	144/142K		16PR		TT	7	7.5;7.00T	259	1019	471	3088	14.5	298
			GAM839	144/142K		16PR	M+S	TT	7	7.5;7.00T	259	1019	471	3088	15.7	298
			GDM680	144/142K		16PR		TT	7	7.5;7.00T	259	1019	471	3088	16.8	298
			GAL817	144/142K		16PR		TT	7	7.5;7.00T	259	1019	471	3088	14.5	298
			GAO822	144/142F		16PR		TT	7	7.5;7.00T	259	1030	476	3121	21.6	298
			GAO829	144/142F		16PR		TT	7	7.5;7.00T	259	1030	476	3121	22	298
		10.00R20	GAM839	149/146K		18PR	M+S	TT	7.5	7.50V;8.0	278	1054	486	3194	16.2	320
			GAO829	149/146F		18PR		TT	7.5	7.50V;8.0	278	1065	491	3227	22.5	320
			GAR558	149/146K		18PR		TT	7.5	7.50V;8.0	278	1054	486	3194	15.0	320
			GAM839	149/146K		18PR	M+S	TT	7.5	7.50V;8.0	278	1054	486	3194	16.2	320
			GDM680	149/146K		18PR	M+S	TT	7.5	7.50V;8.0	278	1065	491	3227	17.2	320
			GSR225	147/143L		16PR	M+S	TT	7.5	7.00T;7.50V; 8.00V	278	1052	485	3188	14	320
		11.00R20	GAR558	152/149K		18PR		TT	8	8.5;8.00V	293	1085	499	3288	15.3	337
			GAM839	152/149K		18PR	M+S	TT	8	8.5;8.00V	293	1085	499	3288	16	337
			GAM839*	152/149K		18PR	M+S	TT	8	8.5;8.00V	293	1085	499	3288	16	337
			GDM625*	152/149K		18PR		TT	8	8.5;8.00V	293	1085	499	3288	18	337
			GDM680	152/149K		18PR		TT	8	8.5;8.00V	293	1096	504	3321	18	337
			GAO822	152/149F		18PR		TT	8	8.5;8.00V	293	1096	504	3321	23.5	337
			GAO829	152/149F		18PR		TT	8	8.5;8.00V	293	1096	504	3321	23.0	337
			GAO852	152/149F		18PR		TT	8	8.5;8.00V	293	1096	504	3321	24	337
			GAR827	150/147K		16PR		TT	8	7.50V;8.00V; 8.50V	293	1085	499	3288	17.2	337
		12.00R20	GAM839	156/153K		20PR	M+S	TT	8.5	8.0;8.5; 9.0;8.50VM	315	1125	516	3409	16	362
			GAM839*	156/153K		20PR	M+S	TT	8.5	8.0;8.5;9.0; 8.50VM	315	1125	516	3409	16	362
			GDM680	156/153J		20PR	M+S	TT	8.5	8.50V;9.00V; 8.5V5°	315	1136	521	3442	19	362
			GAO822	156/153F		20PR		TT	8.5	8.0;8.5;9.0; 8.50VM	315	1136	521	3442	24.5	362
GAO829	156/153F			20PR		TT	8.5	8.50V;9.00V; 8.5V5°	315	1136	521	3442	23.5	362		

### LOAD CAPACITY by AXLE (kg) and PRESSURE (psi/bar)

	Load		Index	S= Single D= Dual	65.25	68.88	72.50	76.13	79.75	83.38	87.00	90.63	94.25	97.88	101.50	105.13	108.75	112.38	116.00	119.63	123.25	126.88	130.50	134.13	137.75
	Single (kg)	Dual (kg)			4.50	4.75	5.00	5.25	5.50	5.75	6.00	6.25	6.50	6.75	7.00	7.25	7.50	7.75	8.00	8.25	8.50	8.75	9.00	9.25	9.50
	2800	2650			144	S	3210	3350	3490	3630	3770	3910	4050	4180	4310	4440	4570	4700	4830	4960	5090	5220	5350	5480	5600
		142	D	6080	6350	6620	6880	7140	7400	7660	7910	8160	8410	8660	8910	9160	9400	9640	9880	10120	10360	10600			
2800	2650	144	S	3210	3350	3490	3630	3770	3910	4050	4180	4310	4440	4570	4700	4830	4960	5090	5220	5350	5480	5600			
		142	D	6080	6350	6620	6880	7140	7400	7660	7910	8160	8410	8660	8910	9160	9400	9640	9880	10120	10360	10600			
2800	2650	144	S	3210	3350	3490	3630	3770	3910	4050	4180	4310	4440	4570	4700	4830	4960	5090	5220	5350	5480	5600			
		142	D	6080	6350	6620	6880	7140	7400	7660	7910	8160	8410	8660	8910	9160	9400	9640	9880	10120	10360	10600			
2800	2650	144	S	3210	3350	3490	3630	3770	3910	4050	4180	4310	4440	4570	4700	4830	4960	5090	5220	5350	5480	5600			
		142	D	6080	6350	6620	6880	7140	7400	7660	7910	8160	8410	8660	8910	9160	9400	9640	9880	10120	10360	10600			
2800	2650	144	S	3210	3350	3490	3630	3770	3910	4050	4180	4310	4440	4570	4700	4830	4960	5090	5220	5350	5480	5600			
		142	D	6080	6350	6620	6880	7140	7400	7660	7910	8160	8410	8660	8910	9160	9400	9640	9880	10120	10360	10600			
3000	2725	146	S	3650	3810	3970	4130	4290	4450	4600	4750	4900	5050	5200	5350	5500	5650	5800	5940	6080	6220	6360	6500		
		146	D	6740	7040	7340	7630	7920	8210	8490	8770	9050	9330	9610	9880	10150	10420	10690	10960	11220	11480	11740	12000		
3250	3000	149	S	3650	3810	3970	4130	4290	4450	4600	4750	4900	5050	5200	5350	5500	5650	5800	5940	6080	6220	6360	6500		
		146	D	6740	7040	7340	7630	7920	8210	8490	8770	9050	9330	9610	9880	10150	10420	10690	10960	11220	11480	11740	12000		
3250	3000	149	S	3650	3810	3970	4130	4290	4450	4600	4750	4900	5050	5200	5350	5500	5650	5800	5940	6080	6220	6360	6500		
		146	D	6740	7040	7340	7630	7920	8210	8490	8770	9050	9330	9610	9880	10150	10420	10690	10960	11220	11480	11740	12000		
3250	3000	149	S	3650	3810	3970	4130	4290	4450	4600	4750	4900	5050	5200	5350	5500	5650	5800	5940	6080	6220	6360	6500		
		146	D	6740	7040	7340	7630	7920	8210	8490	8770	9050	9330	9610	9880	10150	10420	10690	10960	11220	11480	11740	12000		
3075	2725	147	S	3880	4050	4220	4390	4560	4720	4880	5040	5200	5360	5520	5680	5840	6000	6150							
		143	D	6880	7180	7480	7780	8070	8360	8650	8940	9230	9510	9790	10070	10350	10630	10900							
3550	3250	152	S	3990	4170	4340	4510	4680	4850	5020	5190	5360	5520	5680	5840	6000	6160	6320	6480	6640	6800	6950	7100		
		149	D	7300	7620	7940	8260	8570	8880	9190	9500	9800	10100	10400	10700	10990	11280	11570	11860	12150	12440	12720	13000		
3550	3250	152	S	3990	4170	4340	4510	4680	4850	5020	5190	5360	5520	5680	5840	6000	6160	6320	6480	6640	6800	6950	7100		
		149	D	7300	7620	7940	8260	8570	8880	9190	9500	9800	10100	10400	10700	10990	11280	11570	11860	12150	12440	12720	13000		
3550	3250	152	S	3990	4170	4340	4510	4680	4850	5020	5190	5360	5520	5680	5840	6000	6160	6320	6480	6640	6800	6950	7100		
		149	D	7300	7620	7940	8260	8570	8880	9190	9500	9800	10100	10400	10700	10990	11280	11570	11860	12150	12440	12720	13000		
3550	3250	152	S	3990	4170	4340	4510	4680	4850	5020	5190	5360	5520	5680	5840	6000	6160	6320	6480	6640	6800	6950	7100		
		149	D	7300	7620	7940	8260	8570	8880	9190	9500	9800	10100	10400	10700	10990	11280	11570	11860	12150	12440	12720	13000		
3550	3250	152	S	3990	4170	4340	4510	4680	4850	5020	5190	5360	5520	5680	5840	6000	6160	6320	6480	6640	6800	6950	7100		
		149	D	7300	7620	7940	8260	8570	8880	9190	9500	9800	10100	10400	10700	10990	11280	11570	11860	12150	12440	12720	13000		
3350	3075	150	S	4120	4300	4480	4660	4840	5020	5190	5360	5530	5700	5870	6040	6210	6380	6540	6700						
		147	D	7580	7910	8240	8570	8890	9210	9530	9850	10160	10470	10780	11090	11400	11700	12000	12300						
4000	3650	156	S	4590	4790	4990	5190	5390	5590	5780	5970	6160	6350	6540	6730	6920	7100	7280	7460	7640	7820	8000			
		153	D	8380	8750	9120	9480	9840	10200	10550	10900	11250	11590	11930	12270	12610	12950	13280	13610	13940	14270	14600			
4000	3650	156	S	4590	4790	4990	5190	5390	5590	5780	5970	6160	6350	6540	6730	6920	7100	7280	7460	7640	7820	8000			
		153	D	8380	8750	9120	9480	9840	10200	10550	10900	11250	11590	11930	12270	12610	12950	13280	13610	13940	14270	14600			
4000	3650	156	S	4590	4790	4990	5190	5390	5590	5780	5970	6160	6350	6540	6730	6920	7100	7280	7460	7640	7820	8000			
		153	D	8380	8750	9120	9480	9840	10200	10550	10900	11250	11590	11930	12270	12610	12950	13280	13610	13940	14270	14600			
4000	3650	156	S	4590	4790	4990	5190	5390	5590	5780	5970	6160	6350	6540	6730	6920	7100	7280	7460	7640	7820	8000			
		153	D	8380	8750	9120	9480	9840	10200	10550	10900	11250	11590	11930	12270	12610	12950	13280	13610	13940	14270	14600			
4000	3650	156	S	4590	4790	4990	5190	5390	5590	5780	5970	6160	6350	6540	6730	6920	7100	7280	7460	7640	7820	8000			
		153	D	8380	8750	9120	9480	9840	10200	10550	10900	11250	11590	11930	12270	12610	12950	13280	13610	13940	14270	14600			

## TECHNICAL SPECIFICATIONS

Bead	Series	Size	Pattern	Index	Index 2	PR	M+S	Type	 Giti Recommended Rim (Inches)	Approved Rims Width	 Section Width (mm)	 Overall Diameter (mm)	 Static Laden Radius (mm)	 Rolling Circumference (mm)	Original Tread Depth (OTD)	Min. Dual Spacing
20	100	12.00R20	GAO852	156/153F		20PR		TT	8.5	8.50V;9.00V; 8.5V5*	315	1136	521	3442	24	362
			GDM625*	156/153K		20PR		TT	8.5	8.0;8.5;9.0; 8.50VM	315	1125	516	3409	18	362
		14.00R20	GAO897	164/161J		20PR		TL	10	-	375	1253	571	3822	23	422
22.5	90	8R22.5	GAL817	130/128M		14PR		TL	6	5.25;6.75	203	935	440	2852	12.9	228
		9R22.5	GAR558	136/134M		14PR		TL	6.75	6.00;7.50	229	974	457	2971	14	258
			GAL817	136/134M		14PR		TL	6.75	6.00;7.50	229	974	457	2971	13.8	258
			GAU867V1	136/134M		14PR	M+S	TL	6.75	6.00;7.50	229	974	457	2971	17.8	258
		10R22.5	GAR558	144/142M		16PR		TL	7.5	6.75	254	1019	476	3108	14.8	286
			GAU867V1	144/142M		16PR	M+S	TL	7.5	6.75	254	1019	476	3108	17.8	286
			GDR688	144/142M		16PR	M+S	TL	7.5	6.75	254	1019	476	3108	15.8	286
			GAL817	144/142M		16PR		TL	7.5	6.75	254	1019	476	3108	14.8	286
		11R22.5	GAC812	149/146M		18PR		TL	8.25	7.5	279	1054	491	3215	15	314
			GAM835	148/145K		16PR	M+S	TL	8.25	7.5	279	1054	491	3215	19	314
			GAM839	148/145K		16PR	M+S	TL	8.25	7.5	279	1054	491	3215	16.2	314
			GAR558	148/145M		16PR		TL	8.25	7.5	279	1054	491	3215	15.8	314
			GAR827	148/145K		16PR		TL	8.25	7.50;8.25	279	1054	491	3215	17.2	314
			GAR850	143/140J		14PR		TL	8.25	7.5	279	1052	490	3209	14.7	314
			GAU867V1	148/145J		16PR	M+S	TL	8.25	7.5	279	1054	491	3215	18.7	314
			GDL651FS	144/142L		14PR	M+S	TL	8.25	7.5	279	1054	491	3215	20.6	314
			GDL651FS	146/143L		16PR	M+S	TL	8.25	7.50;8.25	279	1054	491	3215	20.6	314
			GDM635	146/143J		16PR	M+S	TL	8.25	7.5	279	1065	495	3248	25.5	314
			GDM686	148/145J		16PR	M+S	TL	8.25	7.5	279	1050	489	3203	22.6	314
			GDR621	148/145L		16PR	M+S	TL	8.25	7.5	279	1065	495	3248	21.4	314
GDR652	148/145L			16PR	M+S	TL	8.25	7.5	279	1065	495	3248	23.8	314		
GDR655	148/145M		16PR	M+S	TL	8.25	7.5	279	1050	489	3203	21	314			
GDR655	148/145M		16PR	M+S	TL	8.25	7.50;8.25	279	1050	489	3203	21	314			

**LOAD CAPACITY by AXLE (kg) and PRESSURE (psi/bar)**

	Load		Index	S= Single  D= Dual	65.25	68.88	72.50	76.13	79.75	83.38	87.00	90.63	94.25	97.88	101.50	105.13	108.75	112.38	116.00	119.63	123.25	126.88	130.50	134.13	137.75
	Single (kg)	Dual (kg)			4.50	4.75	5.00	5.25	5.50	5.75	6.00	6.25	6.50	6.75	7.00	7.25	7.50	7.75	8.00	8.25	8.50	8.75	9.00	9.25	9.50
	4000	3650			156	S	4590	4790	4990	5190	5390	5590	5780	5970	6160	6350	6540	6730	6920	7100	7280	7460	7640	7820	8000
		153	D	8380	8750	9120	9480	9840	10200	10550	10900	11250	11590	11930	12270	12610	12950	13280	13610	13940	14270	14600			
4000	3650	156	S	4590	4790	4990	5190	5390	5590	5780	5970	6160	6350	6540	6730	6920	7100	7280	7460	7640	7820	8000			
		153	D	8380	8750	9120	9480	9840	10200	10550	10900	11250	11590	11930	12270	12610	12950	13280	13610	13940	14270	14600			
5000	4625	164	S	6470	6760	7040	7320	7600	7880	8150	8420	8690	8960	9220	9480	9740	10000								
		161	D	11980	12510	13030	13550	14060	14570	15070	15570	16070	16560	17050	17540	18020	18500								
1900	1800	130	S	2340	2440	2540	2640	2740	2840	2940	3040	3140	3240	3340	3440	3530	3620	3710	3800						
		128	D	4420	4620	4810	5000	5190	5380	5570	5760	5940	6120	6300	6480	6660	6840	7020	7200						
2240	2120	136	S	2760	2880	3000	3120	3240	3360	3480	3600	3710	3820	3930	4040	4150	4260	4370	4480						
		134	D	5220	5450	5680	5910	6130	6350	6570	6790	7010	7220	7430	7640	7850	8060	8270	8480						
2240	2120	136	S	2760	2880	3000	3120	3240	3360	3480	3600	3710	3820	3930	4040	4150	4260	4370	4480						
		134	D	5220	5450	5680	5910	6130	6350	6570	6790	7010	7220	7430	7640	7850	8060	8270	8480						
2240	2120	136	S	2760	2880	3000	3120	3240	3360	3480	3600	3710	3820	3930	4040	4150	4260	4370	4480						
		134	D	5220	5450	5680	5910	6130	6350	6570	6790	7010	7220	7430	7640	7850	8060	8270	8480						
2800	2650	144	S	3210	3350	3490	3630	3770	3910	4050	4180	4310	4440	4570	4700	4830	4960	5090	5220	5350	5480	5600			
		142	D	6080	6350	6620	6880	7140	7400	7660	7910	8160	8410	8660	8910	9160	9400	9640	9880	10120	10360	10600			
2800	2650	144	S	3210	3350	3490	3630	3770	3910	4050	4180	4310	4440	4570	4700	4830	4960	5090	5220	5350	5480	5600			
		142	D	6080	6350	6620	6880	7140	7400	7660	7910	8160	8410	8660	8910	9160	9400	9640	9880	10120	10360	10600			
2800	2650	144	S	3370	3520	3670	3820	3960	4100	4240	4380	4520	4660	4800	4940	5080	5210	5340	5470	5600					
		142	D	6370	6650	6930	7210	7480	7750	8020	8290	8550	8810	9070	9330	9590	9850	10100	10350	10600					
2800	2650	144	S	3210	3350	3490	3630	3770	3910	4050	4180	4310	4440	4570	4700	4830	4960	5090	5220	5350	5480	5600			
		142	D	6080	6350	6620	6880	7140	7400	7660	7910	8160	8410	8660	8910	9160	9400	9640	9880	10120	10360	10600			
3250	3000	149	S	3650	3810	3970	4130	4290	4450	4600	4750	4900	5050	5200	5350	5500	5650	5800	5940	6080	6220	6360	6500		
		146	D	6740	7040	7340	7630	7920	8210	8490	8770	9050	9330	9610	9880	10150	10420	10690	10960	11220	11480	11740	12000		
3150	2900	148	S	3790	3960	4130	4290	4450	4610	4770	4930	5090	5250	5400	5550	5700	5850	6000	6150	6300					
		145	D	6970	7280	7590	7890	8190	8490	8780	9070	9360	9650	9930	10210	10490	10770	11050	11330	11600					
3150	2900	148	S	3790	3960	4130	4290	4450	4610	4770	4930	5090	5250	5400	5550	5700	5850	6000	6150	6300					
		145	D	6970	7280	7590	7890	8190	8490	8780	9070	9360	9650	9930	10210	10490	10770	11050	11330	11600					
3150	2900	148	S	3790	3960	4130	4290	4450	4610	4770	4930	5090	5250	5400	5550	5700	5850	6000	6150	6300					
		145	D	6970	7280	7590	7890	8190	8490	8780	9070	9360	9650	9930	10210	10490	10770	11050	11330	11600					
3150	2900	148	S	3790	3960	4130	4290	4450	4610	4770	4930	5090	5250	5400	5550	5700	5850	6000	6150	6300					
		145	D	6970	7280	7590	7890	8190	8490	8780	9070	9360	9650	9930	10210	10490	10770	11050	11330	11600					
2725	2500	143	S	3820	3990	4160	4330	4490	4650	4810	4970	5130	5290	5450											
		140	D	7020	7330	7640	7940	8240	8540	8840	9130	9420	9710	10000											
3150	2900	148	S	3790	3960	4130	4290	4450	4610	4770	4930	5090	5250	5400	5550	5700	5850	6000	6150	6300					
		145	D	6970	7280	7590	7890	8190	8490	8780	9070	9360	9650	9930	10210	10490	10770	11050	11330	11600					
2800	2650	144	S	3940	4110	4280	4450	4620	4790	4960	5120	5280	5440	5600											
		142	D	7440	7770	8100	8420	8740	9060	9370	9680	9990	10300	10600											
3000	2725	146	S	3690	3850	4010	4170	4330	4490	4650	4800	4950	5100	5250	5400	5550	5700	5850	6000						
		143	D	6700	7000	7290	7580	7870	8160	8440	8720	9000	9280	9550	9820	10090	10360	10630	10900						
3000	2725	146	S	3690	3850	4010	4170	4330	4490	4650	4800	4950	5100	5250	5400	5550	5700	5850	6000						
		143	D	6700	7000	7290	7580	7870	8160	8440	8720	9000	9280	9550	9820	10090	10360	10630	10900						
3150	2900	148	S	3790	3960	4130	4290	4450	4610	4770	4930	5090	5250	5400	5550	5700	5850	6000	6150	6300					
		145	D	6970	7280	7590	7890	8190	8490	8780	9070	9360	9650	9930	10210	10490	10770	11050	11330	11600					
3150	2900	148	S	3790	3960	4130	4290	4450	4610	4770	4930	5090	5250	5400	5550	5700	5850	6000	6150	6300					
		145	D	6970	7280	7590	7890	8190	8490	8780	9070	9360	9650	9930	10210	10490	10770	11050	11330	11600					
3150	2900	148	S	3790	3960	4130	4290	4450	4610	4770	4930	5090	5250	5400	5550	5700	5850	6000	6150	6300					
		145	D	6970	7280	7590	7890	8190	8490	8780	9070	9360	9650	9930	10210	10490	10770	11050	11330	11600					
3150	2900	148	S	3790	3960	4130	4290	4450	4610	4770	4930	5090	5250	5400	5550	5700	5850	6000	6150	6300					
		145	D	6970	7280	7590	7890	8190	8490	8780	9070	9360	9650	9930	10210	10490	10770	11050	11330	11600					
3150	2900	148	S	3790	3960	4130	4290	4450	4610	4770	4930	5090	5250	5400	5550	5700	5850	6000	6150	6300					
		145	D	6970	7280	7590	7890	8190	8490	8780	9070	9360	9650	9930	10210	10490	10770	11050	11330	11600					
3150	2900	148	S	3790	3960	4130	4290	4450	4610	4770	4930	5090	5250	5400	5550	5700	5850	6000	6150	6300					
		145	D	6970	7280	7590	7890	8190	8490	8780	9070	9360	9650	9930	10210	10490	10770	11050	11330	11600					





## TECHNICAL SPECIFICATIONS

Bead	Series	Size	Pattern	Index	Index 2	PR	M+S	Type	 Giti Recommended Rim (Inches)	Approved Rims Width	 Section Width (mm)	 Overall Diameter (mm)	 Static Laden Radius (mm)	 Rolling Circumference (mm)	Original Tread Depth (OTD)	Min. Dual Spacing
22.5	90	11R22.5	GDR688	148/145M		16PR	M+S	TL	8.25	7.5	279	1050	489	3203	17.2	314
			GDW628	148/145L		16PR	M+S	TL	8.25	7.50;8.25	279	1059	493	3230	20.6	314
			GSR225	148/145M		16PR	M+S	TL	8.25	7.5	279	1050	489	3203	15.3	314
			GSR231FS	144/142L		14PR	M+S	TL	8.25	7.5	279	1054	491	3215	16.7	314
			GSR231FS	148/145L		16PR	M+S	TL	8.25	7.5	279	1054	491	3215	16.7	314
			GTL922FS	144/142L		14PR		TL	8.25	7.5	279	1054	491	3215	8.7	314
		12R22.5	GAM839	152/149L		18PR		TL	9	8.25	300	1085	504	3309	16	338
			GAO822	152/149F		18PR		TL	9	8.25	300	1096	509	3343	23.5	338
			GAR558+	152/149M		18PR		TL	9	8.25	300	1085	504	3309	16.3	338
			GDM680	152/149L		18PR		TL	9	8.25	300	1085	504	3309	18	338
			GDM686	152/148K		16PR	M+S	TL	9	8.25	300	1085	504	3309	23.1	338
			GDR688	152/148M		16PR	M+S	TL	9	8.25	300	1085	504	3309	17.2	338
	13R22.5	13R22.5	GAM831	156/150K	154/150L	18PR	M+S	TL	9.75	9	320	1124	521	3428	18.2	360
			GDM686	156/150K		18PR	M+S	TL	9.75	9	320	1124	521	3428	22.09	360
		275/80R22.5	GAR850	151/148J		18PR	M+S	TL	8.25	7.50;8.25; 9.00	276	1012	473	3087	15.5	311
			GAU867V1	149/146J		16PR	M+S	TL	8.25	7.50;8.25	276	1012	473	3087	18.8	311
			GDR665	149/146L		16PR	M+S	TL	8.25	7.50;8.25	276	1012	473	3087	22	311
	295/80R22.5	295/80R22.5	GAC812	152/149M		18PR		TL	9	8.25	298	1044	487	3184	14.8	335
			GAC821	154/149L		18PR	M+S	TL	9	8.25	298	1044	487	3184	18.7	335
			GAM837	154/149K	152/149L	18PR	M+S	TL	9	8.25	298	1044	487	3184	17.5	335
			GAO822	152/149J		18PR		TL	9	8.25	298	1050	489	3203	21	335
			GAR827	152/149K		18PR		TL	9	8.25;9.00	298	1044	487	3184	17.2	335

**LOAD CAPACITY by AXLE (kg) and PRESSURE (psi/bar)**

	Load		Index	S= Single D= Dual	65.25	68.88	72.50	76.13	79.75	83.38	87.00	90.63	94.25	97.88	101.50	105.13	108.75	112.38	116.00	119.63	123.25	126.88	130.50	134.13	137.75
	Single (kg)	Dual (kg)			4.50	4.75	5.00	5.25	5.50	5.75	6.00	6.25	6.50	6.75	7.00	7.25	7.50	7.75	8.00	8.25	8.50	8.75	9.00	9.25	9.50
	3150	2900			148	S	3790	3960	4130	4290	4450	4610	4770	4930	5090	5250	5400	5550	5700	5850	6000	6150	6300		
		145	D	6970	7280	7590	7890	8190	8490	8780	9070	9360	9650	9930	10210	10490	10770	11050	11330	11600					
3150	2900	148	S	3790	3960	4130	4290	4450	4610	4770	4930	5090	5250	5400	5550	5700	5850	6000	6150	6300					
		145	D	6970	7280	7590	7890	8190	8490	8780	9070	9360	9650	9930	10210	10490	10770	11050	11330	11600					
3150	2900	148	S	3790	3960	4130	4290	4450	4610	4770	4930	5090	5250	5400	5550	5700	5850	6000	6150	6300					
		145	D	6970	7280	7590	7890	8190	8490	8780	9070	9360	9650	9930	10210	10490	10770	11050	11330	11600					
2800	2650	144	S	3940	4110	4280	4450	4620	4790	4960	5120	5280	5440	5600											
		142	D	7440	7770	8100	8420	8740	9060	9370	9680	9990	10300	10600											
3150	2900	148	S	3790	3960	4130	4290	4450	4610	4770	4930	5090	5250	5400	5550	5700	5850	6000	6150	6300					
		145	D	6970	7280	7590	7890	8190	8490	8780	9070	9360	9650	9930	10210	10490	10770	11050	11330	11600					
2800	2650	144	S	3940	4110	4280	4450	4620	4790	4960	5120	5280	5440	5600											
		142	D	7440	7770	8100	8420	8740	9060	9370	9680	9990	10300	10600											
3550	3250	152	S	3990	4170	4340	4510	4680	4850	5020	5190	5360	5520	5680	5840	6000	6160	6320	6480	6640	6800	6950	7100		
		149	D	7300	7620	7940	8260	8570	8880	9190	9500	9800	10100	10400	10700	10990	11280	11570	11860	12150	12440	12720	13000		
3550	3250	152	S	3990	4170	4340	4510	4680	4850	5020	5190	5360	5520	5680	5840	6000	6160	6320	6480	6640	6800	6950	7100		
		149	D	7300	7620	7940	8260	8570	8880	9190	9500	9800	10100	10400	10700	10990	11280	11570	11860	12150	12440	12720	13000		
3550	3250	152	S	3990	4170	4340	4510	4680	4850	5020	5190	5360	5520	5680	5840	6000	6160	6320	6480	6640	6800	6950	7100		
		149	D	7300	7620	7940	8260	8570	8880	9190	9500	9800	10100	10400	10700	10990	11280	11570	11860	12150	12440	12720	13000		
3550	3150	152	S	4270	4460	4650	4830	5010	5190	5370	5550	5730	5910	6080	6250	6420	6590	6760	6930	7100					
		148	D	7580	7910	8240	8570	8890	9210	9530	9850	10160	10470	10780	11090	11400	11700	12000	12300	12600					
3550	3150	152	S	4270	4460	4650	4830	5010	5190	5370	5550	5730	5910	6080	6250	6420	6590	6760	6930	7100					
		148	D	7580	7910	8240	8570	8890	9210	9530	9850	10160	10470	10780	11090	11400	11700	12000	12300	12600					
3550	3250	152	S	3990	4170	4340	4510	4680	4850	5020	5190	5360	5520	5680	5840	6000	6160	6320	6480	6640	6800	6950	7100		
		149	D	7300	7620	7940	8260	8570	8880	9190	9500	9800	10100	10400	10700	10990	11280	11570	11860	12150	12440	12720	13000		
3550	3250	152	S	3990	4170	4340	4510	4680	4850	5020	5190	5360	5520	5680	5840	6000	6160	6320	6480	6640	6800	6950	7100		
		149	D	7300	7620	7940	8260	8570	8880	9190	9500	9800	10100	10400	10700	10990	11280	11570	11860	12150	12440	12720	13000		
4000	3350	156	S	4700	4910	5120	5320	5520	5720	5920	6120	6310	6500	6690	6880	7070	7260	7450	7640	7820	8000				
		150	D	7880	8230	8570	8910	9250	9580	9910	10240	10570	10890	11210	11530	11850	12160	12470	12780	13090	13400				
4000	3350	156	S	4700	4910	5120	5320	5520	5720	5920	6120	6310	6500	6690	6880	7070	7260	7450	7640	7820	8000				
		150	D	7880	8230	8570	8910	9250	9580	9910	10240	10570	10890	11210	11530	11850	12160	12470	12780	13090	13400				
3450	3150	151	S	3960	4140	4310	4480	4650	4820	4990	5160	5320	5480	5640	5800	5960	6120	6280	6440	6600	6750	6900			
		148	D	7240	7560	7880	8190	8500	8810	9110	9410	9710	10010	10310	10600	10890	11180	11470	11760	12040	12320	12600			
3250	3000	149	S	3910	4080	4250	4420	4590	4760	4920	5080	5240	5400	5560	5720	5880	6040	6200	6350	6500					
		146	D	7220	7540	7860	8170	8480	8790	9090	9390	9690	9990	10280	10570	10860	11150	11440	11720	12000					
3250	3000	149	S	3910	4080	4250	4420	4590	4760	4920	5080	5240	5400	5560	5720	5880	6040	6200	6350	6500					
		146	D	7220	7540	7860	8170	8480	8790	9090	9390	9690	9990	10280	10570	10860	11150	11440	11720	12000					
3250	3000	149	S	3910	4080	4250	4420	4590	4760	4920	5080	5240	5400	5560	5720	5880	6040	6200	6350	6500					
		146	D	7220	7540	7860	8170	8480	8790	9090	9390	9690	9990	10280	10570	10860	11150	11440	11720	12000					
3550	3250	152	S	4080	4260	4440	4620	4790	4960	5130	5300	5470	5640	5810	5980	6140	6300	6460	6620	6780	6940	7100			
		149	D	7470	7800	8130	8450	8770	9090	9400	9710	10020	10330	10640	10940	11240	11540	11840	12130	12420	12710	13000			
3750	3250	154	S	4500	4700	4900	5100	5290	5480	5670	5860	6050	6240	6420	6600	6780	6960	7140	7320	7500					
		149	D	7810	8160	8500	8840	9180	9510	9840	10170	10490	10810	11130	11450	11760	12070	12380	12690	13000					
3750	3250	154	S	4500	4700	4900	5100	5290	5480	5670	5860	6050	6240	6420	6600	6780	6960	7140	7320	7500					
		149	D	7810	8160	8500	8840	9180	9510	9840	10170	10490	10810	11130	11450	11760	12070	12380	12690	13000					
3550	3250	152	S	4080	4260	4440	4620	4790	4960	5130	5300	5470	5640	5810	5980	6140	6300	6460	6620	6780	6940	7100			
		149	D	7470	7800	8130	8450	8770	9090	9400	9710	10020	10330	10640	10940	11240	11540	11840	12130	12420	12710	13000			
3550	3250	152	S	4080	4260	4440	4620	4790	4960	5130	5300	5470	5640	5810	5980	6140	6300	6460	6620	6780	6940	7100			
		149	D	7470	7800	8130	8450	8770	9090	9400	9710	10020	10330	10640	10940	11240	11540	11840	12130	12420	12710	13000			

## TECHNICAL SPECIFICATIONS

Bead	Series	Size	Pattern	Index	Index 2	PR	M+S	Type	 Giti Recommended Rim (Inches)	Approved Rims Width	 Section Width (mm)	 Overall Diameter (mm)	 Static Laden Radius (mm)	 Rolling Circumference (mm)	Original Tread Depth (OTD)	Min. Dual Spacing
22.5	80	295/80R22.5	GAR850	153/150J		18PR	M+S	TL	9	8.25	298	1044	487	3184	15.5	335
			GAU867V1	154/150J		18PR	M+S	TL	9	8.25	298	1044	487	3184	18.7	335
			GAU867V1	154/150J		18PR	M+S	TL	9	8.25;9.00	298	1044	487	3184	18.7	335
			GDC629	152/148M		16PR	M+S	TL	9	8.25	298	1044	487	3184	17.2	335
			GDL617	152/148M		16PR	M+S	TL	9	8.25	298	1044	487	3184	17.5	335
			GDM686	152/149K		18PR	M+S	TL	9	8.25	298	1050	489	3203	22.6	335
			GDR655	152/149M		18PR	M+S	TL	9	8.25	298	1050	489	3203	21.1	335
			GDR665	152/149M		18PR	M+S	TL	9	8.25	298	1044	487	3184	21.1	335
			GSR225	154/149M		18PR	M+S	TL	9	8.25;9.00	298	1044	487	3184	16.5	335
			GSR237	152/149M		18PR	M+S	TL	9	8.25	298	1044	487	3184	16.5	335
	315/80R22.5	GAM831	158/150K	154/150L	18PR	M+S	TL	9	9.75	312	1076	500	3282	18.2	351	
		GAM835	161/157J		22PR	M+S	TL	9	9.75	312	1076	500	3282	19	351	
		GDL617	156/150L	154/150M	18PR	M+S	TL	9	9.75	312	1076	500	3282	18.2	351	
		GDM686	158/150K		20PR	M+S	TL	9	9.75	312	1076	500	3282	23.1	351	
		GDR621	158/150L	154/150M	20PR	M+S	TL	9	9.75	312	1076	500	3282	23.1	351	
		GDR655	156/150L	154/150M	18PR	M+S	TL	9	9.75	312	1076	500	3282	21	351	
		GDR665	156/150L	154/150M	18PR	M+S	TL	9	9.75	312	1076	500	3282	21	351	
		GSR225	158/150L	154/150M	20PR	M+S	TL	9	9.75	312	1076	500	3282	16.8	351	
		GSW226	158/150L	154/150M	18PR	M+S	TL	9	9.75	312	1076	500	3282	16.8	351	
		GT867	158/150J		18PR	M+S	TL	9	9.75	312	1076	500	3282	18.7	351	
	GTR926	156/150M		18PR		TL	9	9.75	312	1076	500	3282	13	351		
	75	295/75R22.5	GDL651FS	144/141L		14PR	M+S	TL	9	8.25;9.00	298	1020	476	3111	20.6	335
GDR652			144/141L		14PR	M+S	TL	9	8.25;9.00	298	1026	479	3129	23.8	335	
GSL229FS			144/141L		14PR		TL	9	8.25;9.00	298	1014	474	3093	15.1	335	
GSR231FS			144/141L		14PR	M+S	TL	9	8.25;9.00	298	1014	474	3093	16.7	335	
GTL922FS			144/141L		14PR		TL	9	8.25;9.00	298	1014	474	3093	8.7	335	



**LOAD CAPACITY by AXLE (kg) and PRESSURE (psi/bar)**

	Load		Index	S= Single D= Dual	65.25	68.88	72.50	76.13	79.75	83.38	87.00	90.63	94.25	97.88	101.50	105.13	108.75	112.38	116.00	119.63	123.25	126.88	130.50	134.13	137.75
	Single (kg)	Dual (kg)			4.50	4.75	5.00	5.25	5.50	5.75	6.00	6.25	6.50	6.75	7.00	7.25	7.50	7.75	8.00	8.25	8.50	8.75	9.00	9.25	9.50
3650	3350	153	S	4190	4380	4560	4740	4920	5100	5280	5460	5630	5800	5970	6140	6310	6480	6650	6820	6980	7140	7300			
		150	D	7700	8040	8380	8710	9040	9370	9690	10010	10330	10650	10960	11270	11580	11890	12200	12500	12800	13100	13400			
3750	3350	154	S	4310	4500	4690	4880	5060	5240	5420	5600	5780	5960	6140	6310	6480	6650	6820	6990	7160	7330	7500			
		150	D	7700	8040	8380	8710	9040	9370	9690	10010	10330	10650	10960	11270	11580	11890	12200	12500	12800	13100	13400			
3750	3350	154	S	4310	4500	4690	4880	5060	5240	5420	5600	5780	5960	6140	6310	6480	6650	6820	6990	7160	7330	7500			
		150	D	7700	8040	8380	8710	9040	9370	9690	10010	10330	10650	10960	11270	11580	11890	12200	12500	12800	13100	13400			
3550	3150	152	S	4270	4460	4650	4830	5010	5190	5370	5550	5730	5910	6080	6250	6420	6590	6760	6930	7100					
		148	D	7580	7910	8240	8570	8890	9210	9530	9850	10160	10470	10780	11090	11400	11700	12000	12300	12600					
3550	3150	152	S	4270	4460	4650	4830	5010	5190	5370	5550	5730	5910	6080	6250	6420	6590	6760	6930	7100					
		148	D	7580	7910	8240	8570	8890	9210	9530	9850	10160	10470	10780	11090	11400	11700	12000	12300	12600					
3550	3250	152	S	4080	4260	4440	4620	4790	4960	5130	5300	5470	5640	5810	5980	6140	6300	6460	6620	6780	6940	7100			
		149	D	7470	7800	8130	8450	8770	9090	9400	9710	10020	10330	10640	10940	11240	11540	11840	12130	12420	12710	13000			
3550	3250	152	S	4080	4260	4440	4620	4790	4960	5130	5300	5470	5640	5810	5980	6140	6300	6460	6620	6780	6940	7100			
		149	D	7470	7800	8130	8450	8770	9090	9400	9710	10020	10330	10640	10940	11240	11540	11840	12130	12420	12710	13000			
3550	3250	152	S	4080	4260	4440	4620	4790	4960	5130	5300	5470	5640	5810	5980	6140	6300	6460	6620	6780	6940	7100			
		149	D	7470	7800	8130	8450	8770	9090	9400	9710	10020	10330	10640	10940	11240	11540	11840	12130	12420	12710	13000			
3750	3250	154	S	4500	4700	4900	5100	5290	5480	5670	5860	6050	6240	6420	6600	6780	6960	7140	7320	7500					
		149	D	7810	8160	8500	8840	9180	9510	9840	10170	10490	10810	11130	11450	11760	12070	12380	12690	13000					
3550	3250	152	S	4080	4260	4440	4620	4790	4960	5130	5300	5470	5640	5810	5980	6140	6300	6460	6620	6780	6940	7100			
		149	D	7470	7800	8130	8450	8770	9090	9400	9710	10020	10330	10640	10940	11240	11540	11840	12130	12420	12710	13000			
4250	3350	158	S	4880	5100	5310	5520	5730	5940	6150	6350	6550	6750	6950	7150	7350	7550	7740	7930	8120	8310	8500			
		150	D	7700	8040	8380	8710	9040	9370	9690	10010	10330	10650	10960	11270	11580	11890	12200	12500	12800	13100	13400			
4625	4125	161	S	5310	5540	5770	6000	6230	6460	6680	6900	7120	7340	7560	7780	7990	8200	8410	8620	8830	9040	9250			
		157	D	9480	9900	10310	10720	11130	11530	11930	12330	12720	13110	13500	13880	14260	14640	15020	15390	15760	16130	16500			
4000	3350	156	S	4810	5020	5230	5440	5650	5850	6050	6250	6450	6650	6850	7050	7240	7430	7620	7810	8000					
		150	D	8050	8410	8760	9110	9460	9800	10140	10480	10810	11140	11470	11800	12120	12440	12760	13080	13400					
4250	3350	158	S	4810	5020	5230	5440	5650	5850	6050	6250	6450	6650	6850	7050	7240	7430	7620	7810	8000					
		150	D	8050	8410	8760	9110	9460	9800	10140	10480	10810	11140	11470	11800	12120	12440	12760	13080	13400					
4250	3350	158	S	4880	5100	5310	5520	5730	5940	6150	6350	6550	6750	6950	7150	7350	7550	7740	7930	8120	8310	8500			
		150	D	7700	8040	8380	8710	9040	9370	9690	10010	10330	10650	10960	11270	11580	11890	12200	12500	12800	13100	13400			
4000	3350	156	S	4810	5020	5230	5440	5650	5850	6050	6250	6450	6650	6850	7050	7240	7430	7620	7810	8000					
		150	D	8050	8410	8760	9110	9460	9800	10140	10480	10810	11140	11470	11800	12120	12440	12760	13080	13400					
4000	3350	156	S	4810	5020	5230	5440	5650	5850	6050	6250	6450	6650	6850	7050	7240	7430	7620	7810	8000					
		150	D	8050	8410	8760	9110	9460	9800	10140	10480	10810	11140	11470	11800	12120	12440	12760	13080	13400					
4250	3350	158	S	4880	5100	5310	5520	5730	5940	6150	6350	6550	6750	6950	7150	7350	7550	7740	7930	8120	8310	8500			
		150	D	7700	8040	8380	8710	9040	9370	9690	10010	10330	10650	10960	11270	11580	11890	12200	12500	12800	13100	13400			
4250	3350	158	S	4880	5100	5310	5520	5730	5940	6150	6350	6550	6750	6950	7150	7350	7550	7740	7930	8120	8310	8500			
		150	D	7700	8040	8380	8710	9040	9370	9690	10010	10330	10650	10960	11270	11580	11890	12200	12500	12800	13100	13400			
4000	3350	156	S	4810	5020	5230	5440	5650	5850	6050	6250	6450	6650	6850	7050	7240	7430	7620	7810	8000					
		150	D	8050	8410	8760	9110	9460	9800	10140	10480	10810	11140	11470	11800	12120	12440	12760	13080	13400					
2800	2575	144	S	3730	3890	4050	4210	4370	4530	4690	4850	5000	5150	5300	5450	5600									
		141	D	6840	7140	7440	7740	8030	8320	8610	8900	9180	9460	9740	10020	10300									
2800	2575	144	S	3730	3890	4050	4210	4370	4530	4690	4850	5000	5150	5300	5450	5600									
		141	D	6840	7140	7440	7740	8030	8320	8610	8900	9180	9460	9740	10020	10300									
2800	2575	141	S	3730	3890	4050	4210	4370	4530	4690	4850	5000	5150	5300	5450	5600									
		144	D	6840	7140	7440	7740	8030	8320	8610	8900	9180	9460	9740	10020	10300									
2800	2575	144	S	3730	3890	4050	4210	4370	4530	4690	4850	5000	5150	5300	5450	5600									
		141	D	6840	7140	7440	7740	8030	8320	8610	8900	9180	9460	9740	10020	10300									
2800	2575	144	S	3730	3890	4050	4210	4370	4530	4690	4850	5000	5150	5300	5450	5600									
		141	D	6840	7140	7440	7740	8030	8320	8610	8900	9180	9460	9740	10020	10300									





## TECHNICAL SPECIFICATIONS

Bead	Series	Size	Pattern	Index	Index 2	PR	M+S	Type	 Giti Recommended Rim (Inches)	Approved Rims Width	 Section Width (mm)	 Overall Diameter (mm)	 Static Laden Radius (mm)	 Rolling Circumference (mm)	Original Tread Depth (OTD)	Min. Dual Spacing	
22.5	70	255/70R22.5	GAL817	140/137M		16PR		TL	7.5	8.25	255	930	434	2837	14.8	287	
			GAU867V1	140/137J		16PR	M+S	TL	7.5	8.25	255	930	434	2837	17	287	
			GTL922FS	140/137L		16PR		TL	7.5	8.25	255	930	434	2837	8.7	287	
		275/70R22.5	GAR827	148/145K		16PR		TL	8.25	7.5	276	958	445	2922	18.5	311	
			GAU861	150/145J	154/148E	16PR	M+S	TL	8.25	7.5	276	958	445	2922	20.2	311	
			GAU867V1	152/148J	154/148F	18PR	M+S	TL	8.25	9	276	958	445	2922	18.7	311	
			GDM676	148/145K		16PR	M+S	TL	8.25	7.5	276	958	445	2922	20.6	311	
			GSR225	148/145M	152/148J	18PR	M+S	TL	8.25	9	276	958	445	2922	15.0	311	
		305/70R22.5	GT867	151/148J		20PR	M+S	TL	9	8.25	305	1006	465	3068	19	343	
			GT867	152/150J	154/150E	16PR	M+S	TL	9	8.25	305	1000	463	3050	19	343	
		315/70R22.5	GAM837	156/150K	154/150L	18PR	M+S	TL	9	9.75	312	1014	468	3093	17.5	351	
			GDL617	154/150L	152/148M	18PR	M+S	TL	9	9.75	312	1014	468	3093	17.5	351	
			GDR621	154/150L	152/148M	18PR	M+S	TL	9	9.75	312	1014	468	3093	21.0	351	
			GDR655	154/150L	152/148M	20PR	M+S	TL	9	9.75	312	1014	468	3093	21	351	
			GSR225	156/150L	154/150M	20PR	M+S	TL	9	9.75	312	1014	468	3093	15.5	351	
			GSW226	156/150L	154/150M	18PR	M+S	TL	9	9.75	312	1014	468	3093	15.5	351	
		65	385/65R22.5	GAM851	164K	158L	20PR	M+S	TL	11.75	12.25	389	1072	496	3248	17	438
				GSR259	164K	160L	20PR	M+S	TL	11.75	12.25	389	1072	496	3248	15	438
	GSW226			164K	160L	20PR	M+S	TL	11.75	12.25	389	1072	496	3248	16	438	
	GTL919+			164K	158L	20PR	M+S	TL	11.75	12.25	389	1072	496	3248	15.5	438	
	GTR955			164K	158L	20PR	M+S	TL	11.75	11.75;12.25	389	1072	496	3248	15.5	438	
	425/65R22.5		GAM851	165K		20PR	M+S	TL	12.25	11.75;12.25; 13.00;14.00	422	1124	518	3406	18	475	
			GTL919	165K		20PR	M+S	TL	12.25	11.75;12.25; 13.00;14.00	422	1124	518	3406	15.3	475	
	445/65R22.5		GAM851	169K		20PR	M+S	TL	13	12.25;13.00; 14.00	444	1150	529	3485	18	500	
	60		295/60R22.5	GDL617	150/147K	149/146L	18PR	M+S	TL	9	9.75	292	932	437	2824	18.2	329
				GSR225	150/147L		18PR	M+S	TL	9	9.75	292	926	435	2806	15	329

### LOAD CAPACITY by AXLE (kg) and PRESSURE (psi/bar)

	Load		Index	S= Single D= Dual	65.25	68.88	72.50	76.13	79.75	83.38	87.00	90.63	94.25	97.88	101.50	105.13	108.75	112.38	116.00	119.63	123.25	126.88	130.50	134.13	137.75	
	Single (kg)	Dual (kg)			4.50	4.75	5.00	5.25	5.50	5.75	6.00	6.25	6.50	6.75	7.00	7.25	7.50	7.75	8.00	8.25	8.50	8.75	9.00	9.25	9.50	
	2500	2300			140	S	3080	3220	3350	3480	3610	3740	3870	4000	4130	4260	4390	4520	4640	4760	4880	5000				
		137	D	5660	5910	6160	6410	6650	6890	7130	7370	7600	7830	8060	8290	8520	8750	8980	9200							
2500	2300	140	S	3080	3220	3350	3480	3610	3740	3870	4000	4130	4260	4390	4520	4640	4760	4880	5000							
		137	D	5660	5910	6160	6410	6650	6890	7130	7370	7600	7830	8060	8290	8520	8750	8980	9200							
2500	2300	140	S	3080	3220	3350	3480	3610	3740	3870	4000	4130	4260	4390	4520	4640	4760	4880	5000							
		137	D	5660	5910	6160	6410	6650	6890	7130	7370	7600	7830	8060	8290	8520	8750	8980	9200							
3150	2900	148	S	3620	3780	3940	4100	4260	4410	4560	4710	4860	5010	5160	5310	5460	5600	5740	5880	6020	6160	6300				
		145	D	6670	6960	7250	7540	7830	8110	8390	8670	8950	9220	9490	9760	10030	10300	10560	10820	11080	11340	11600				
3350	2900	150	S	3840	4010	4180	4350	4520	4680	4840	5000	5160	5320	5480	5640	5800	5950	6100	6250	6400	6550	6700				
		145	D	6670	6960	7250	7540	7830	8110	8390	8670	8950	9220	9490	9760	10030	10300	10560	10820	11080	11340	11600				
3550	3150	152	S	4080	4260	4440	4620	4790	4960	5130	5300	5470	5640	5810	5980	6140	6300	6460	6620	6780	6940	7100				
		148	D	7240	7560	7880	8190	8500	8810	9110	9410	9710	10010	10310	10600	10890	11180	11470	11760	12040	12320	12600				
3150	2900	148	S	3620	3780	3940	4100	4260	4410	4560	4710	4860	5010	5160	5310	5460	5600	5740	5880	6020	6160	6300				
		145	D	6670	6960	7250	7540	7830	8110	8390	8670	8950	9220	9490	9760	10030	10300	10560	10820	11080	11340	11600				
3150	2900	148	S	3620	3780	3940	4100	4260	4410	4560	4710	4860	5010	5160	5310	5460	5600	5740	5880	6020	6160	6300				
		145	D	6670	6960	7250	7540	7830	8110	8390	8670	8950	9220	9490	9760	10030	10300	10560	10820	11080	11340	11600				
3450	3150	151	S	3960	4140	4310	4480	4650	4820	4990	5160	5320	5480	5640	5800	5960	6120	6280	6440	6600	6750	6900				
		148	D	7240	7560	7880	8190	8500	8810	9110	9410	9710	10010	10310	10600	10890	11180	11470	11760	12040	12320	12600				
3550	3350	152	S	4270	4460	4650	4830	5010	5190	5370	5550	5730	5910	6080	6250	6420	6590	6760	6930	7100						
		150	D	8050	8410	8760	9110	9460	9800	10140	10480	10810	11140	11470	11800	12120	12440	12760	13080	13400						
4000	3350	156	S	4590	4790	4990	5190	5390	5590	5780	5970	6160	6350	6540	6730	6920	7100	7280	7460	7640	7820	8000				
		150	D	7700	8040	8380	8710	9040	9370	9690	10010	10330	10650	10960	11270	11580	11890	12200	12500	12800	13100	13400				
3750	3350	154	S	4310	4500	4690	4880	5060	5240	5420	5600	5780	5960	6140	6310	6480	6650	6820	6990	7160	7330	7500				
		150	D	7700	8040	8380	8710	9040	9370	9690	10010	10330	10650	10960	11270	11580	11890	12200	12500	12800	13100	13400				
3750	3350	154	S	4310	4500	4690	4880	5060	5240	5420	5600	5780	5960	6140	6310	6480	6650	6820	6990	7160	7330	7500				
		150	D	7700	8040	8380	8710	9040	9370	9690	10010	10330	10650	10960	11270	11580	11890	12200	12500	12800	13100	13400				
3750	3350	154	S	4310	4500	4690	4880	5060	5240	5420	5600	5780	5960	6140	6310	6480	6650	6820	6990	7160	7330	7500				
		150	D	7700	8040	8380	8710	9040	9370	9690	10010	10330	10650	10960	11270	11580	11890	12200	12500	12800	13100	13400				
4000	3350	156	S	4590	4790	4990	5190	5390	5590	5780	5970	6160	6350	6540	6730	6920	7100	7280	7460	7640	7820	8000				
		150	D	7700	8040	8380	8710	9040	9370	9690	10010	10330	10650	10960	11270	11580	11890	12200	12500	12800	13100	13400				
4000	3350	156	S	4590	4790	4990	5190	5390	5590	5780	5970	6160	6350	6540	6730	6920	7100	7280	7460	7640	7820	8000				
		150	D	7700	8040	8380	8710	9040	9370	9690	10010	10330	10650	10960	11270	11580	11890	12200	12500	12800	13100	13400				
5000	-	164	S	5750	6000	6250	6500	6750	6990	7230	7470	7710	7950	8180	8410	8640	8870	9100	9330	9560	9780	10000				
5000	-	164	S	5750	6000	6250	6500	6750	6990	7230	7470	7710	7950	8180	8410	8640	8870	9100	9330	9560	9780	10000				
5000	-	164	S	5750	6000	6250	6500	6750	6990	7230	7470	7710	7950	8180	8410	8640	8870	9100	9330	9560	9780	10000				
5000	-	164	S	5750	6000	6250	6500	6750	6990	7230	7470	7710	7950	8180	8410	8640	8870	9100	9330	9560	9780	10000				
5000	-	164	S	5750	6000	6250	6500	6750	6990	7230	7470	7710	7950	8180	8410	8640	8870	9100	9330	9560	9780	10000				
5150	-	165	S	6340	6620	6900	7170	7440	7710	7980	8250	8510	8770	9030	9290	9550	9800	10050	10300							
5150	-	165	S	6340	6620	6900	7170	7440	7710	7980	8250	8510	8770	9030	9290	9550	9800	10050	10300							
5800	-	169	S	6670	6960	7250	7540	7830	8110	8390	8670	8950	9220	9490	9760	10030	10300	10560	10820	11080	11340	11600				
3350	3075	150	S	3840	4010	4180	4350	4520	4680	4840	5000	5160	5320	5480	5640	5800	5950	6100	6250	6400	6550	6700				
		147	D	7060	7370	7680	7990	8290	8590	8890	9190	9480	9770	10060	10350	10630	10910	11190	11470	11750	12030	12300				
3350	3075	150	S	3840	4010	4180	4350	4520	4680	4840	5000	5160	5320	5480	5640	5800	5950	6100	6250	6400	6550	6700				
		147	D	7060	7370	7680	7990	8290	8590	8890	9190	9480	9770	10060	10350	10630	10910	11190	11470	11750	12030	12300				

## TECHNICAL SPECIFICATIONS

Bead	Series	Size	Pattern	Index	Index 2	PR	M+S	Type	 Giti Recommended Rim (Inches)	Approved Rims Width	 Section Width (mm)	 Overall Diameter (mm)	 Static Laden Radius (mm)	 Rolling Circumference (mm)	Original Tread Depth (OTD)	Min. Dual Spacing
22.5	60	315/60R22.5	GDL617	152/148L		18PR	M+S	TL	9.75	9	313	950	445	2879	18.2	352
			GSR225	154/148L		20PR	M+S	TL	9.75	9	313	950	445	2879	13.5	352
	55	385/55R22.5	GSR259	158L	160K	18PR	M+S	TL	12.25	11.75	386	996	464	3018	14.5	434
			GSW226	158L	160J	18PR	M+S	TL	12.25	11.75	386	996	464	3018	15.5	434
			GTL919	160K	158L	20PR	M+S	TL	12.25	11.75	386	996	464	3018	14.8	434
			GTR955	160K	158L	20PR	M+S	TL	12.25	12.25;11.75	386	996	464	3018	14.8	434
	50	445/50R22.5	GDL633FS	161L		20PR	M+S	TL	14	15	445	1018	473	3085	18.2	501
			GTL933FS	161L		20PR		TL	14	15	445	1018	473	3085	11.1	501
24	100	12.00R24	GAM833	160/156K		20PR	M+S	TT	8.5	8.50V;9.00V; 8.5V5°	313	1226	567	3715	15.0	360
			GAO822	160/156F		20PR		TT	8.5	8.50V;9.00V; 8.5V5°	313	1226	567	3715	31	360
			GDM623	160/156K		20PR	M+S	TT	8.5	8.50V;9.00V; 8.5V5°	313	1226	567	3715	20.2	360
	95	325/95R24	GAM833	162/160K		22PR	M+S	TL/TT	9	8.5;9.0;10.00; 10.00W; 10.03VA	325	1228	568	3721	17	374
GDM623			162/160K		22PR	M+S	TL/TT	9	8.5;9.0;10.00; 10.00W; 10.02VA	325	1228	568	3721	20.2	374	
24.5	75	285/75R24.5	GDL651FS	144/141L		14PR	M+S	TL	8.25	7.50;8.25; 9.00	283	1056	495	3221	20.6	318
			GTL922FS	144/141L		14PR		TL	8.25	7.50;8.25; 9.00	283	1050	493	3203	8.7	318
	100	11R24.5	GAM835	149/146K		16PR	M+S	TL	8.25	7.50;8.25	279	1104	516	3367	19	314
			GDL651FS	146/143L		14PR	M+S	TL	8.25	7.50;8.25	279	1110	518	3386	20.6	314
			GDL651FS	149/146L		16PR	M+S	TL	8.25	7.50;8.25	279	1110	518	3386	20.6	314
			GDM635	149/146J		16PR	M+S	TL	8.25	7.50;8.25	279	1116	521	3404	25.5	314
			GDR621	149/146L		16PR	M+S	TL	8.25	7.50;8.25	279	1104	516	3367	21.4	314
			GDR652	146/143L		14PR	M+S	TL	8.25	7.50;8.25	279	1116	521	3404	23.8	314
			GDR652	149/146L		16PR	M+S	TL	8.25	7.50;8.25	279	1116	521	3404	23.8	314
			GDW628	149/146L		16PR	M+S	TL	8.25	7.50;8.25	279	1110	518	3386	20.6	314
GTL922FS	146/143L		14PR		TL	8.25	7.50;8.25	279	1104	516	3367	8.7	314			
25	100	14.00R25	GAO898	-		★★★		TT	10.00/2.0	10.00/1.5	375	1370	630	4151	26	431

**Notes:** The bold printed load figures (shown in kg per axle, single/dual configuration) indicate the MAXIMUM designed carrying capacity of the tire when inflated to the corresponding cold pressure shown on the vertical column heading of the table.

### LOAD CAPACITY by AXLE (kg) and PRESSURE (psi/bar)

	Load		Index	S= Single D= Dual	65.25	68.88	72.50	76.13	79.75	83.38	87.00	90.63	94.25	97.88	101.50	105.13	108.75	112.38	116.00	119.63	123.25	126.88	130.50	134.13	137.75
	Single (kg)	Dual (kg)			4.50	4.75	5.00	5.25	5.50	5.75	6.00	6.25	6.50	6.75	7.00	7.25	7.50	7.75	8.00	8.25	8.50	8.75	9.00	9.25	9.50
3550	3150	152	S	4080	4260	4440	4620	4790	4960	5130	5300	5470	5640	5810	5980	6140	6300	6460	6620	6780	6940	7100			
		148	D	7240	7560	7880	8190	8500	8810	9110	9410	9710	10010	10310	10600	10890	11180	11470	11760	12040	12320	12600			
3750	3150	154	S	4310	4500	4690	4880	5060	5240	5420	5600	5780	5960	6140	6310	6480	6650	6820	6990	7160	7330	7500			
		148	D	7240	7560	7880	8190	8500	8810	9110	9410	9710	10010	10310	10600	10890	11180	11470	11760	12040	12320	12600			
4250		158	S	5110	5340	5560	5780	6000	6220	6440	6650	6860	7070	7280	7490	7700	7900	8100	8300	8500					
4250		158	S	5110	5340	5560	5780	6000	6220	6440	6650	6860	7070	7280	7490	7700	7900	8100	8300	8500					
4500		160	S	5170	5400	5630	5850	6070	6290	6510	6730	6940	7150	7360	7570	7780	7990	8200	8400	8600	8800	9000			
4500		160	S	5170	5400	5630	5850	6070	6290	6510	6730	6940	7150	7360	7570	7780	7990	8200	8400	8600	8800	9000			
4625		161	S	5700	5950	6200	6450	6690	6930	7170	7410	7650	7880	8110	8340	8570	8800	9030	9250						
4625		161	S	5700	5950	6200	6450	6690	6930	7170	7410	7650	7880	8110	8340	8570	8800	9030	9250						
4500	4000	160	S	5410	5650	5890	6120	6350	6580	6810	7040	7260	7480	7700	7920	8140	8360	8580	8790	9000					
		156	D	9610	10040	10460	10880	11290	11700	12110	12510	12910	13310	13700	14090	14480	14860	15240	15620	16000					
4500	4000	160	S	5410	5650	5890	6120	6350	6580	6810	7040	7260	7480	7700	7920	8140	8360	8580	8790	9000					
		156	D	9610	10040	10460	10880	11290	11700	12110	12510	12910	13310	13700	14090	14480	14860	15240	15620	16000					
4500	4000	160	S	5410	5650	5890	6120	6350	6580	6810	7040	7260	7480	7700	7920	8140	8360	8580	8790	9000					
		156	D	9610	10040	10460	10880	11290	11700	12110	12510	12910	13310	13700	14090	14480	14860	15240	15620	16000					
4750	4500	162	S	5710	5960	6210	6460	6710	6950	7190	7430	7670	7900	8130	8360	8590	8820	9050	9280	9500					
		160	D	10820	11300	11770	12240	12700	13160	13620	14070	14520	14970	15410	15850	16290	16720	17150	17580	18000					
4750	4500	162	S	5710	5960	6210	6460	6710	6950	7190	7430	7670	7900	8130	8360	8590	8820	9050	9280	9500					
		160	D	10820	11300	11770	12240	12700	13160	13620	14070	14520	14970	15410	15850	16290	16720	17150	17580	18000					
2800	2575	144	S	3730	3890	4050	4210	4370	4530	4690	4850	5000	5150	5300	5450	5600									
		141	D	6840	7140	7440	7740	8030	8320	8610	8900	9180	9460	9740	10020	10300									
2800	2575	144	S	3730	3890	4050	4210	4370	4530	4690	4850	5000	5150	5300	5450	5600									
		141	D	6840	7140	7440	7740	8030	8320	8610	8900	9180	9460	9740	10020	10300									
3250	3000	149	S	4000	4180	4360	4530	4700	4870	5040	5210	5380	5540	5700	5860	6020	6180	6340	6500						
		146	D	7390	7720	8040	8360	8680	8990	9300	9610	9920	10220	10520	10820	11120	11420	11710	12000						
3000	2725	146	S	4220	4410	4590	4770	4950	5130	5310	5490	5660	5830	6000											
		143	D	7660	8000	8330	8660	8990	9320	9640	9960	10280	10590	10900											
3250	3000	149	S	4000	4180	4360	4530	4700	4870	5040	5210	5380	5540	5700	5860	6020	6180	6340	6500						
		146	D	7390	7720	8040	8360	8680	8990	9300	9610	9920	10220	10520	10820	11120	11420	11710	12000						
3250	3000	149	S	4000	4180	4360	4530	4700	4870	5040	5210	5380	5540	5700	5860	6020	6180	6340	6500						
		146	D	7390	7720	8040	8360	8680	8990	9300	9610	9920	10220	10520	10820	11120	11420	11710	12000						
3250	3000	149	S	4000	4180	4360	4530	4700	4870	5040	5210	5380	5540	5700	5860	6020	6180	6340	6500						
		146	D	7390	7720	8040	8360	8680	8990	9300	9610	9920	10220	10520	10820	11120	11420	11710	12000						
3000	2725	146	S	4220	4410	4590	4770	4950	5130	5310	5490	5660	5830	6000											
		143	D	7660	8000	8330	8660	8990	9320	9640	9960	10280	10590	10900											
3250	3000	149	S	4000	4180	4360	4530	4700	4870	5040	5210	5380	5540	5700	5860	6020	6180	6340	6500						
		146	D	7390	7720	8040	8360	8680	8990	9300	9610	9920	10220	10520	10820	11120	11420	11710	12000						
3250	3000	149	S	4000	4180	4360	4530	4700	4870	5040	5210	5380	5540	5700	5860	6020	6180	6340	6500						
		146	D	7390	7720	8040	8360	8680	8990	9300	9610	9920	10220	10520	10820	11120	11420	11710	12000						
3000	2725	146	S	4220	4410	4590	4770	4950	5130	5310	5490	5660	5830	6000											
		143	D	7660	8000	8330	8660	8990	9320	9640	9960	10280	10590	10900											
10000	5800	0	S	11000	11490	11970	12450	12920	13390	13850	14310	14770	15220	15670	16120	16560	17000	17440	17870	18300	18730	19160	19580	20000	
		-	D	16280	17000	17710	18420	19120	19810	20500	21180	21860	22530	23200											

## **Section 8**

# **Wheel Rim Classification**

# Wheel Rim Classification

Rim is a critical part connecting the tire to the wheel.

General requirement for a rim is: good quality and light weight:

Small balance difference, small vibration, fast heat dissipation, easy mounting/demounting, etc.

## I ) Rim classification

### 1. By major type (2 versions)

One piece rim: Rigid structure with deep well  
(For tubeless tire)

Three piece rim: Consisting of rim body,  
flange and locking ring (For tube tire)

### 2. By rim profile (7 types):

Drop center rim and wide deep cut rim: Code DC & WDC  
(For tubeless tire)

Flat base rim and wide flat base rim: Code FB & WFB  
(For tube tire)

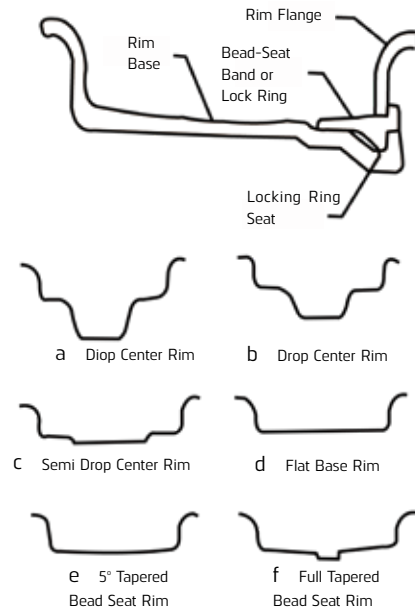

### I type flat base rim (FB-I)

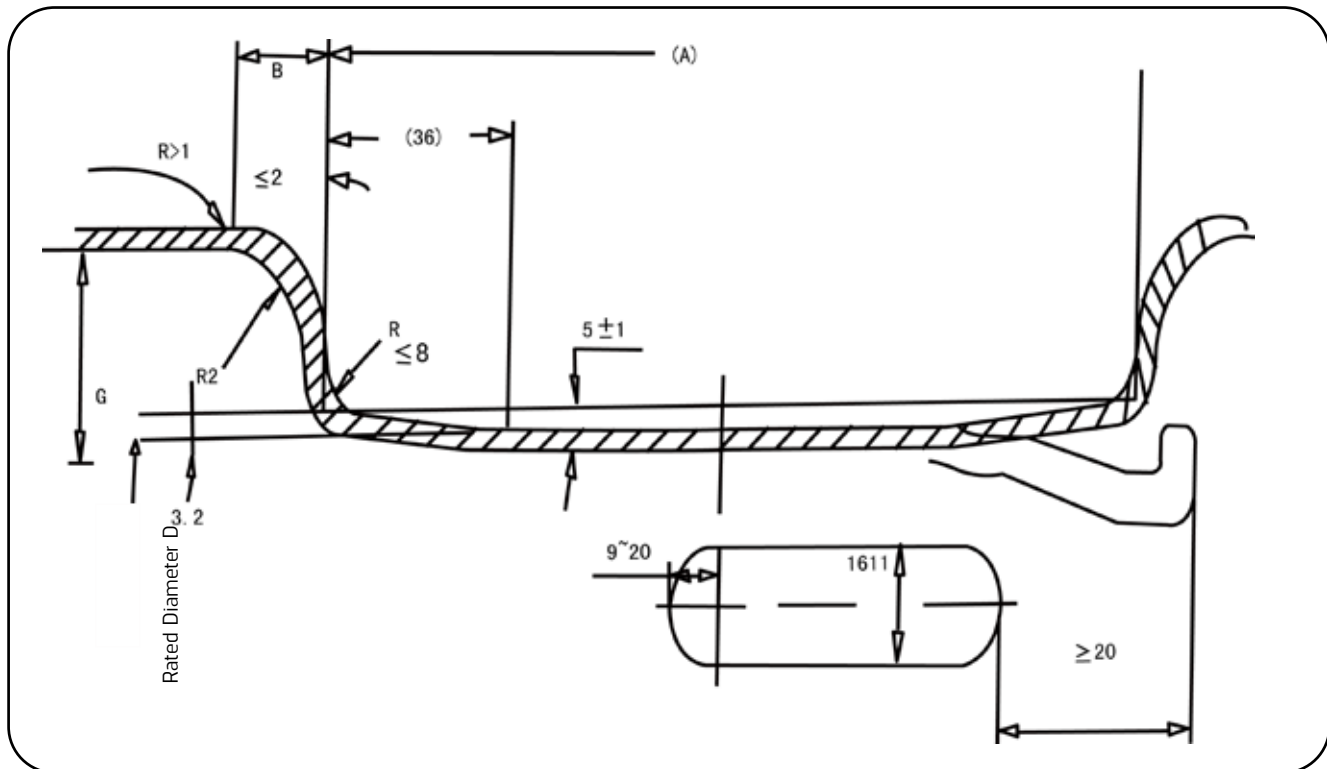

# Wheel Rim Classification

## 15° Drop Center Rim (15°DC) (Tubeless)

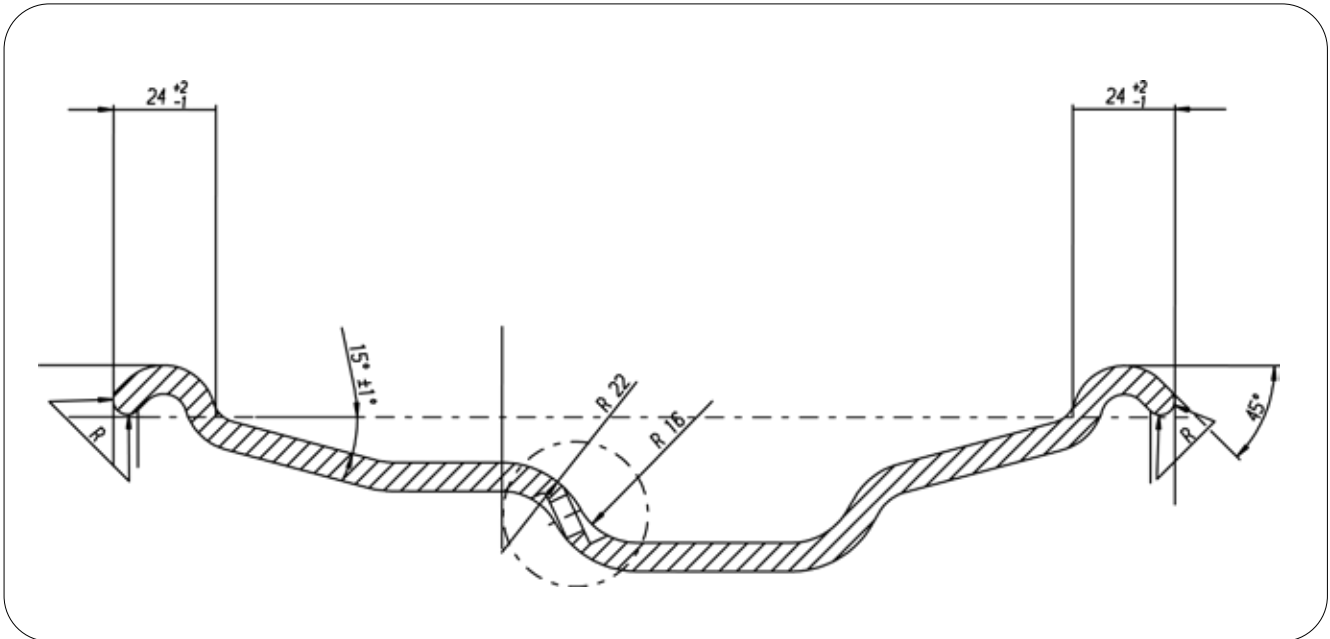

\*R=16 radius may be reduced. But L must be increased at the same time to allow tire mounting/demounting.

\*\*Valve hole may be on the side of rim profile or on the bottom.

Rim impact on tire service life. Distance between rim and dual wheel.

## II ) Rim of dual wheels

If gap between dual wheels is within 20 mm, it is possible to touch during Drive.

Dual space = Offset X 2 - Tire section width

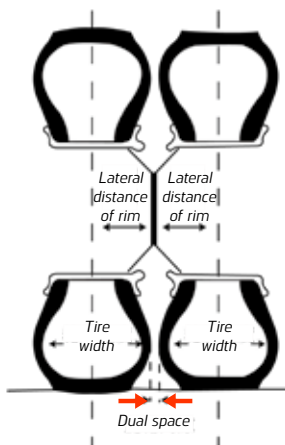

(Example) If dual space is within 20 mm,

load of vehicle is .....

(Tire specification: 10.00R20) (Pressure: 7.25 kg/cm<sup>2</sup>)

Rim	Offset (mm)	Vehicle model	Vehicle load rate (%)
7.00T X 20	158		140
			190
7.50V X 20	165		220
			300



# Wheel Rim Classification

## Rim Offset

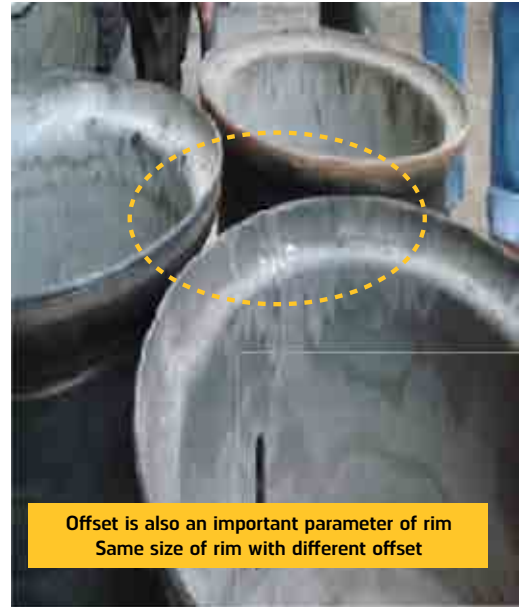
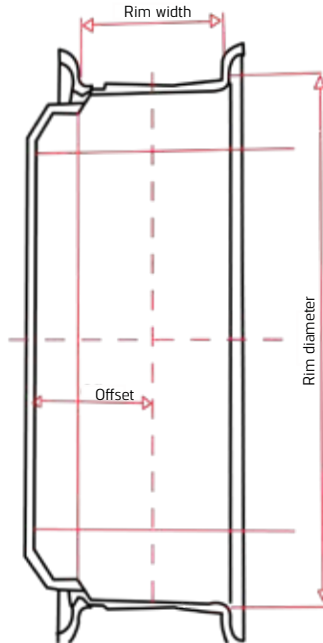

Offset is also an important parameter of rim  
Same size of rim with different offset

## TT & TL specification change guidance list

Bias	Radial	90 series	80 series	75 series	70 series	65 series
7.00-16	7.00R16	8R175	/	/	/	/
7.50-16	7.50R16	8.5R175	225/80R175	215/75R175	/	/
8.25-16	8.25R16	9.5R175	/	235/75R175	245/70R19.5	/
7.50-20	7.50R20	8R22.5	/	/	/	/
8.25-20	8.25R20	9R22.5	/	/	/	/
9.00-20	9.00R20	10R22.5	/	/	255/70R22.5	/
10.00-20	10.00R20	11R22.5	275/80R22.5	/	275/70R22.5	/
11.00-20	11.00R20	12R22.5	295/80R22.5	/	/	385/65R22.5
12.00-20	12.00R20	13R22.5	315/80R22.5	/	315/70R22.5	425/65R22.5

**Note.** This list is for reference only. Please do inquire with local supplier when changing TT to TL. Factors like rim and tire specification, load and vehicle control should also be considered.

## Tire Service Knowledge

- Refer to local standards in your country (if available) for new tire inflation.
- Before mounting tube to new tire, please check whether there is any foreign object inside tire. Secure valve pad nut to avoid air leakage.
- No moisture, oil or liquid should be contained in air inflated. Air inflated should be kept dry.
- Keep proper tire inflation pressure and check regularly.
- After inflating with standard pressure, check and adjust after 15 minutes in case that air temperature decrease leads to pressure decrease.  
Tire rotation can avoid uneven wear, which can be done after each 8,000-12,000 km mileage.
- For long haul high speed transport and summer operation, pressure should be checked regularly, with more breaks. Tire should be cooled down for inflation. Vehicles should be stopped for heat dissipation if tire is overheated or the internal pressure goes up. Do not deflate to decrease pressure or cool it with cold water.
- Check deformation, air leakage or change of valve.







[www.gitifleet.com](http://www.gitifleet.com)